

AMERICAN PNEUMATIC TOOL

APT MODEL 155 ROCK DRILL

TOOL PART NO.		CHUCK SIZE
WET	DRY	
5230	5229	7/8" hex x 3 1/4"
5232	5231	7/8" hex x 4 1/4"
5234	5233	1" hex x 4 1/4"

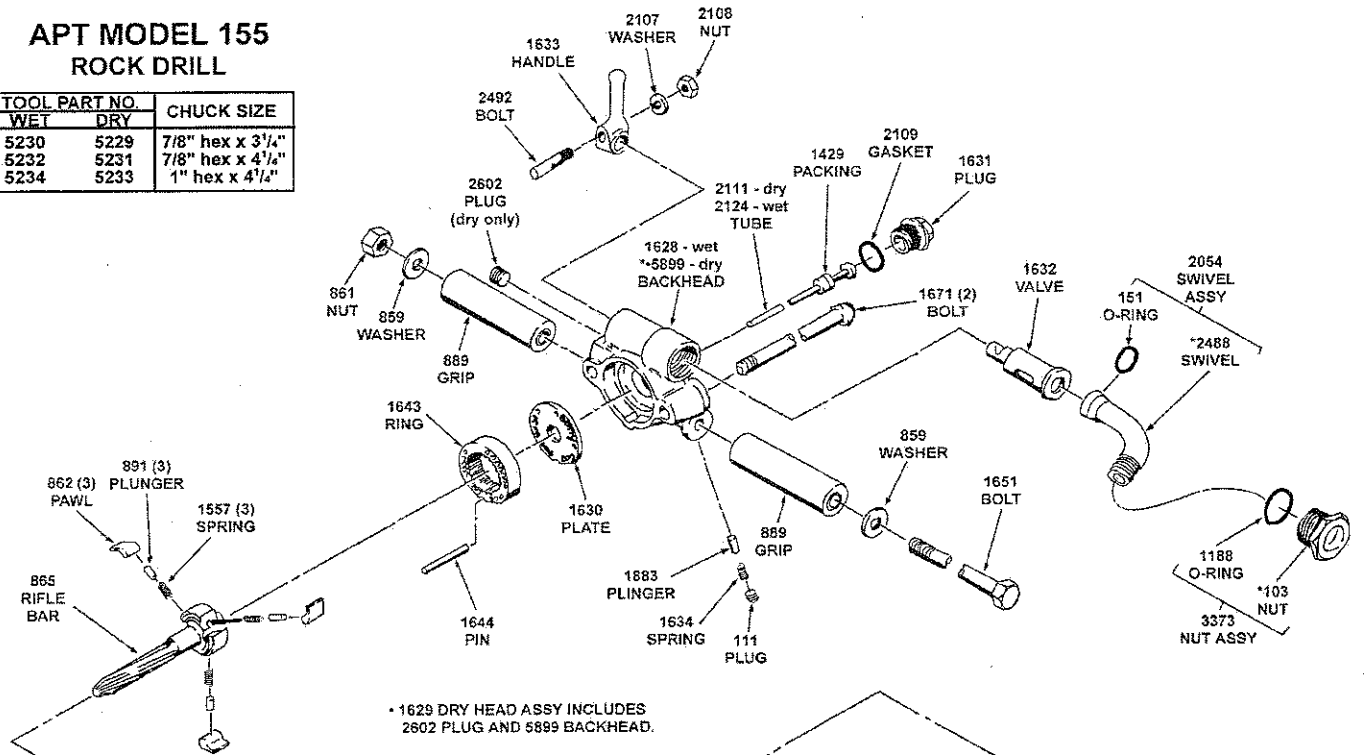

* 1629 DRY HEAD ASSY INCLUDES
2602 PLUG AND 5899 BACKHEAD.

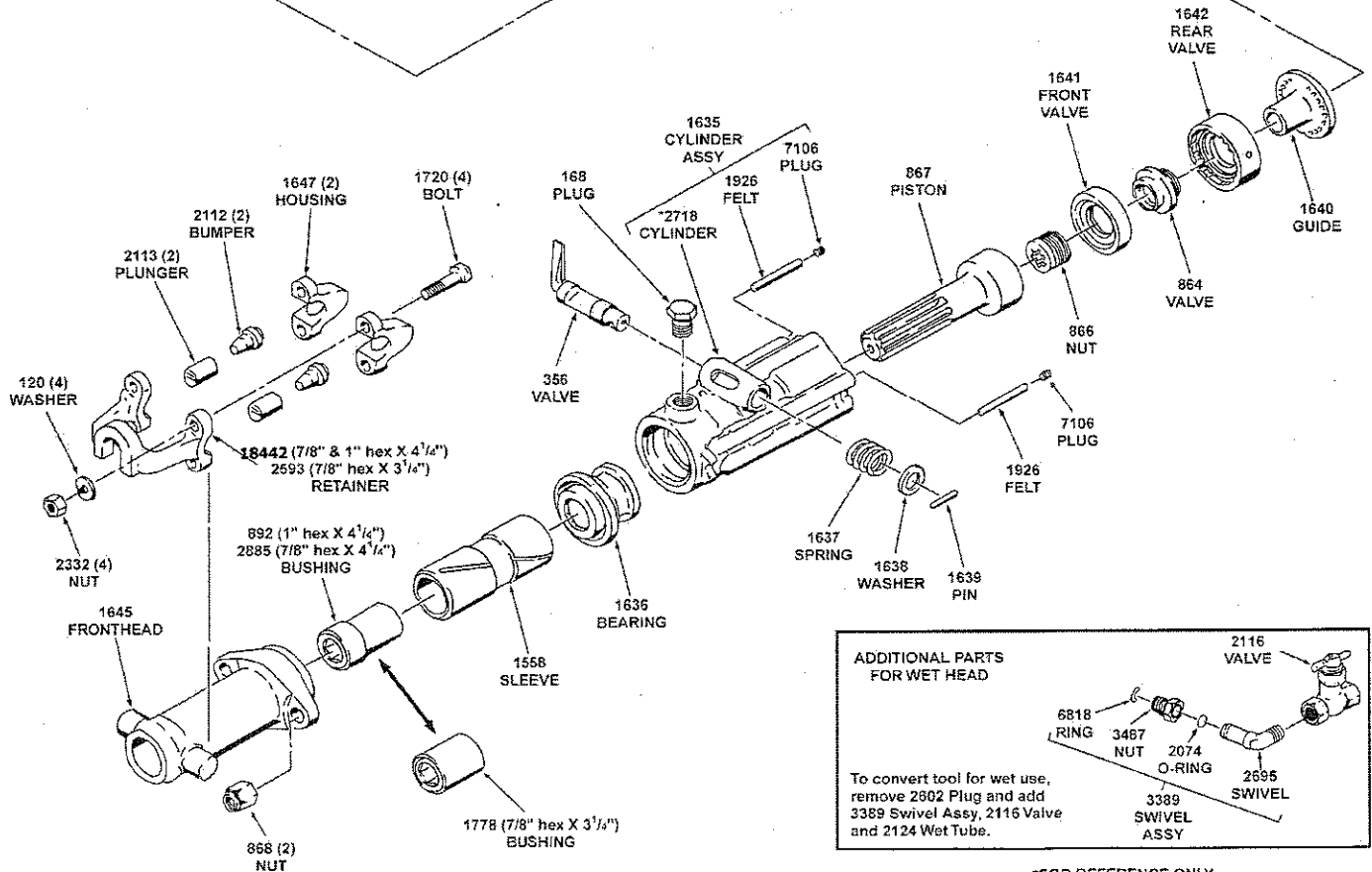

ADDITIONAL PARTS FOR WET HEAD

To convert tool for wet use, remove 2602 Plug and add 3389 Swivel Assy, 2116 Valve and 2124 Wet Tube.

*FOR REFERENCE ONLY
(THESE PARTS NOT SOLD SEPARATELY)

CROWDER SUPPLY COMPANY 8495 ROSLYN ST., COMMERCE CITY, COLORADO 80022 TOLL FREE 888-883-5144 WWW.CROWDERSUPPLY.COM

