

Overhauling instructions

Motor breaker

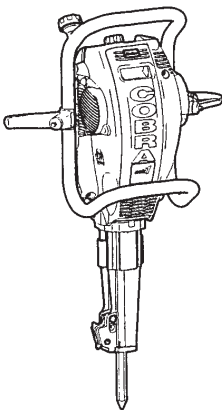

# Cobra mk1

# Cobra TT

## Safety regulations



This symbol, plus a word, is used to draw your attention to safety hazards. Read the instructions accompanying this symbol carefully.

The words WARNING and CAUTION have the following significance:

<b>WARNING</b>	Indicates a hazard or hazardous procedure which <b>COULD</b> result in serious injury or death if the warning is not observed.
<b>CAUTION</b>	Indicates a hazard or hazardous procedures which <b>COULD</b> result in serious injury or damage to equipment if the warning is not observed.



### WARNING

**The machine must not be modified without the manufacturer's authorization. Use only original parts and accessories approved by Atlas Copco. If modifications are made that are not approved by Atlas Copco, serious harm to yourself or others may result.**

*Use only authorized parts. Any damage or malfunction caused by the use of unauthorized parts is not covered by warranty or product liability.*

*Any unauthorized use or copying of the contents or any part thereof is prohibited. This applies in particular to trademarks, model designations, part numbers and drawings.*

## Innehåll

<b>Technical data</b> .....	4	Reassembly of starter mechanism .....	15
Engine .....	4	<b>Filter housing and carburettor</b> .....	16
Transmission unit .....	4	Dismantling of filter housing .....	16
Hammer unit .....	5	Dismantling and reassembly of choke control and lever .....	16
Tightening torque loads .....	5	Dismantling of carburettor and diaphragm valve. .	16
Special assembly instructions .....	5	<b>Engine and hammer mechanism</b> .....	17
<b>Service schedule</b> .....	6	Dismantling of muffler, stabilizer brace and engine mounting bolts .....	17
<b>Design and function</b> .....	7	Dismantling of the engine from the machine. ....	17
Engine .....	7	Dismantling of the muffler, heat shield and fuel tank .....	18
Hammer mechanism .....	7	Dismantling of the anti-vibration springs .....	18
<b>Service tools</b> .....	8	Dismantling of the tool holder .....	18
<b>Engine covers</b> .....	12	Dismantling of the tool shank .....	19
Dismantling of the machine .....	12	Dismantling and reassembly of the tool latch . . .	19
Dismantling of the covers .....	12	Dismantling .....	19
Service cover .....	12	Reassembly .....	19
Front cover .....	12	Dismantling and reassembly of the hammer piston and hammer piston guide. . .	20
Rear cover .....	13	Dismantling .....	20
Filter cover .....	13	Reassembly .....	20
Fan cover .....	13	Dismantling of the drive piston .....	21
Starter cover .....	13	Dismantling and reassembly of the connecting rod bearings .....	21
<b>Starter mechanism</b> .....	14	Dismantling of plastic bushes .....	22
Replacing starter rope with starter pulley in place	14	Mounting the engine on the fixture .....	22
Dismantling .....	14	Dismantling of the cooling fan .....	22
Reassembly .....	14		
Replacement of starter rope, starter pulley and spring. ....	14		

Dismantling of the electronic unit, carriers and flywheel . . . . .	23	Reassembly . . . . .	36
Dismantling of the engine cylinder and piston. . . . .	23	Reassembly of fuel tank and muffler. . . . .	36
Dismantling of the transmission cover. . . . .	24	Reassembly of engine. . . . .	36
Dismantling of the fan side crankcase. . . . .	24	Fitting the muffler and stabilizer brace . . . . .	37
Dismantling of the hammer crankshaft gear wheel	25	Reassembly of filter housing . . . . .	37
Dismantling of the hammer crankshaft . . . . .	25	Reassembly of machine covers . . . . .	38
Dismantling of the hammer crankshaft bearing. . . . .	26	Throttle cable adjustment . . . . .	38
Dismantling of the engine crankshaft . . . . .	26	Front cover . . . . .	38
Dismantling and reassembly of the engine crankshaft bearing and seal . . . . .	26		
Dismantling . . . . .	26		
Reassembly . . . . .	26		
Reassembly of engine crankshaft . . . . .	27		
Reassembly of crankshaft seal . . . . .	27		
Reassembly of hammer crankshaft bearing . . . . .	27		
Reassembly of locking ring . . . . .	27		
Reassembly of hammer crankshaft. . . . .	28		
Reassembly of locking ring on hammer crankshaft . . . . .	28		
Reassembly of hammer crankshaft gear wheel . . . . .	28		
Dismantling of transmission cover needle bearing and seal . . . . .	29		
Reassembling the transmission cover needle bearing. . . . .	29		
Dismantling of the engine crankshaft bearing and seal on the fan side crankcase. . . . .	29		
Fitting the engine crankshaft bearing on the fan side crankcase. . . . .	29		
Reassembly of the drive piston connecting rod and engine crankcase . . . . .	30		
Assembly of fan side crankcase seal . . . . .	30		
Reassembly of transmission cover . . . . .	31		
Reassembly of the transmission cover seal . . . . .	31		
Reassembly of the engine piston and cylinder . . . . .	31		
Reassembly of the carrier, flywheel and electronics unit. . . . .	32		
Reassembly of cooling fan . . . . .	32		
Reassembly of plastic bushes. . . . .	33		
Reassembly of driver piston . . . . .	33		
Reassembly of tool shank . . . . .	33		
Fitting the hammer cylinder on the tool holder . . . . .	33		
Reassembly of anti-vibration springs . . . . .	34		
Dismantling and reassembly of right handle . . . . .	34		
Dismantling and reassembly of fuel filter. . . . .	35		
Dismantling and reassembly of throttle handle . . . . .	35		
Dismantling . . . . .	35		

# Technical data

Rated power	2.0 kW (2.7 hp)
Sound pressure level	96 dB(A)
Weight	24 kg (.020")
Length	927 mm (.020")
Depth	331 mm (.020")
Width across handles	661 mm (.020")
Width, handles folded	390 mm (.020")
Width across machine	320 mm (.020")
Tool shank	32 × 160 mm 32 × 152 mm 28 × 152 mm 28 × 160 mm

## Engine

Type	Single cylinder, fan-cooled 2-stroke engine
Cylinder volume	90 cc
Engine speed, machine under load, full speed when tamping in sand	5800–6200 rpm (Cobra mk1) 6500+/-100 rpm (Cobra TT)
Engine speed, machine under no load, idling	1800–2200 rpm
Max. speed under no-load conditions	7500 rpm
Ignition	Breakerless, transistor type with integral speed restrictor set to 7700 rev/min
Spark plugs	Champion RCJ8
Electrode gap	0.6-0.7mm
Fuel system	Diaphragm carburettor
Fuel:	Petrol 90-100 octane, leaded or unleaded
Fuel mixture	2 % (1:50)
Tank capacity	1.0 l
Fuel consumption	1.3 l/h
Cooling system	Fan-cooled
Starter device	Magnapull

## Transmission unit

Gear oil	Diesel engine oil SAE 15W/40 API:CD
Oil capacity	0.1 litre
Transmission ratio (The transmission ratio is a primary number selected at random )	1:4.3

## Hammer unit

Hammer frequency	24 Hz (Cobra mk1) 27 Hz (Cobra TT)
Impacts/min	1440 (Cobra mk1) 1620 (Cobra TT)
Impact energy	60 J at 24 Hz (Cobra mk1) 40 J at 27 Hz (Cobra TT)
Lubrication	Hammer mechanism lubricated in its own oil bath
Hammer mechanism oil	Diesel engine oil SAE 15W/40 API:CD
Oil capacity	0.1 litre
Oil consumption	0.015 l/h

## Tightening torque loads

**Note:** The indicated tightening torque loads are for oiled threads.

Flywheel	35 Nm
Fan (A)	25 Nm
Fan (B) (plastic)	8 Nm
Nuts and screws for covers	10 Nm
M8 Engine / Hammer cylinder	23 Nm
M8 Tool holder	20 Nm
M5 Engine cylinder screws	10 Nm
M5 Diaphragm valve screws	8 Nm
M6 Studs on crankcase halves	4–5 Nm
Decompression valve	20 Nm
Spark plug	20Nm

## Special assembly instructions

### Reassembly of KM nut and gear wheel, see fig. 47.

Degrease the transmission shaft and gear wheel taper with denatured alcohol or pure petrol.

Locate the gear wheel on the transmission shaft taper. Screw the KM nut by hand until it makes contact with the gear wheel. Then tighten the nut by half a turn (180°) using service tool S18.

### Reassembly or dismantling of starter device spring.

Always wear safety gloves and safety glasses when reassembling or dismantling the starter spring.

# Service schedule

The machine service interval is based on an operating time of 10 hammering hours per week.

## 1. Daily service or service after every rental. Service time: 5 minutes.

1.1 Check the oil level in the hammer cylinder. The correct oil level is up to the thread in the filler pipe with the machine standing upright. Use diesel engine oil SAE 15W/40, API:CD for the best function and service life.  
**Note:** The oil capacity of the hammer cylinder is 0.1 litre.

1.2 Clean the air filter, filter housing and cover. When working under extremely dusty conditions, replacement of the air filter may be necessary.  
**Note:** Do not use compressed air to clean the air filter, as it may damage the filter material.

## 2. Every week or after 10 hammering hours. Service time: 10 minutes. Measures under Point 1, plus:

2.1 Remove the spark plug. Clean with a wire brush and reset the gap to 0.6-0.7mm.

## 3. Every month or after 50 hammering hours. Service time: 20 minutes. Measures under Point 1, plus:

3.1 Replace the spark plug. All Atlas Copco's spark plugs are preset to 0.6–0.7 mm.

3.2 Replace the air filter.

3.3 Remove and clean the decompression valve.

3.4 Clean any deposits from the exhaust pipe and the muffler. Always replace the seals.

3.5 Check the gap between the flywheel magneto and the electronics unit.  
The correct gap is 0.25 – 0.3 mm.

3.6 Examine the starter rope for wear, and replace if worn or damaged.

3.7 Check the oil level in the gearbox by unscrewing the oil plug. The correct oil level is at the bottom edge of the filler hole with the machine standing upright. If necessary, top up with diesel engine oil SAE 15W40 API:CD.  
**Note:** The oil capacity of the gearbox is 0.1 litre

## 4. Every three months or after 150 hammering hours. Service time: 30 minutes. Measures under Points 1 and 3, plus:

4.1 Examine the scraper ring and sealing ring of the hammer piston guide for wear. Oil running along the tool shank is an indication that the scraper ring is worn. The scraper ring and the sealing ring can be replaced easily.

See Chapter: Dismantling and reassembly of hammer piston guide

4.2 Examine the stabilizer brace and the ball joints for wear, and replace if worn or damaged.

## 5. Every six months or after 250 hammering hours. Service time: 60 minutes. Measures under Points 1, 3 and 4, plus:

5.1 Examine the starting device carriers for wear and the function of the carrier springs. Replace if necessary.

5.2 Replace the fuel filter.

5.3 Replace the crankcase ventilation filter.

5.4 Examine the fuel cap 'O' ring for wear and replace if necessary.

5.5 Examine the anti-vibration springs for wear.

5.6 Replace the piston ring and O-ring on the drive piston and the piston ring and O-ring on the hammer piston.

5.7 Examine the tool shank for wear. Use the gauge supplied with the machine. Replace the tool shank if it has exceeded the wear threshold.

## 6. Every twelve months or after 500 hammering hours. Service time: 5 hours. Measures under Points 1, 3, 4 and 5, plus:

6.1 Dismantle the engine from the hammer cylinder. Examine the hammer piston connecting rod bearings for wear, and replace if necessary.

6.2 Examine the gearbox gear wheels for wear. Dismantle the flywheel and examine the gear wheel for wear. Remove the transmission cover and examine the crankshaft gear wheel for wear.  
**Note:** If any of the gear wheels are worn and need to be replaced, both gear wheels must be replaced.

6.3 Dismantle the engine cylinder and examine the cylinder for wear. Dismantle the piston rings and try the rings in the cylinder. The gap between the ends of the piston rings must not exceed 0.45 mm. Piston ring groove clearance should not exceed 0.15 mm.

6.4 Dismantle the engine. Replace the bearings and seals of the engine and the hammer crankshaft.

6.5 Examine the hammer piston for wear. Replace the piston rod if it is scratched, or if the hammer surface of the piston rod is worn or damaged.

6.6 Examine the diaphragm valve for wear and damage, and replace if necessary.

6.7 Replace the tank cover.

# Design and function

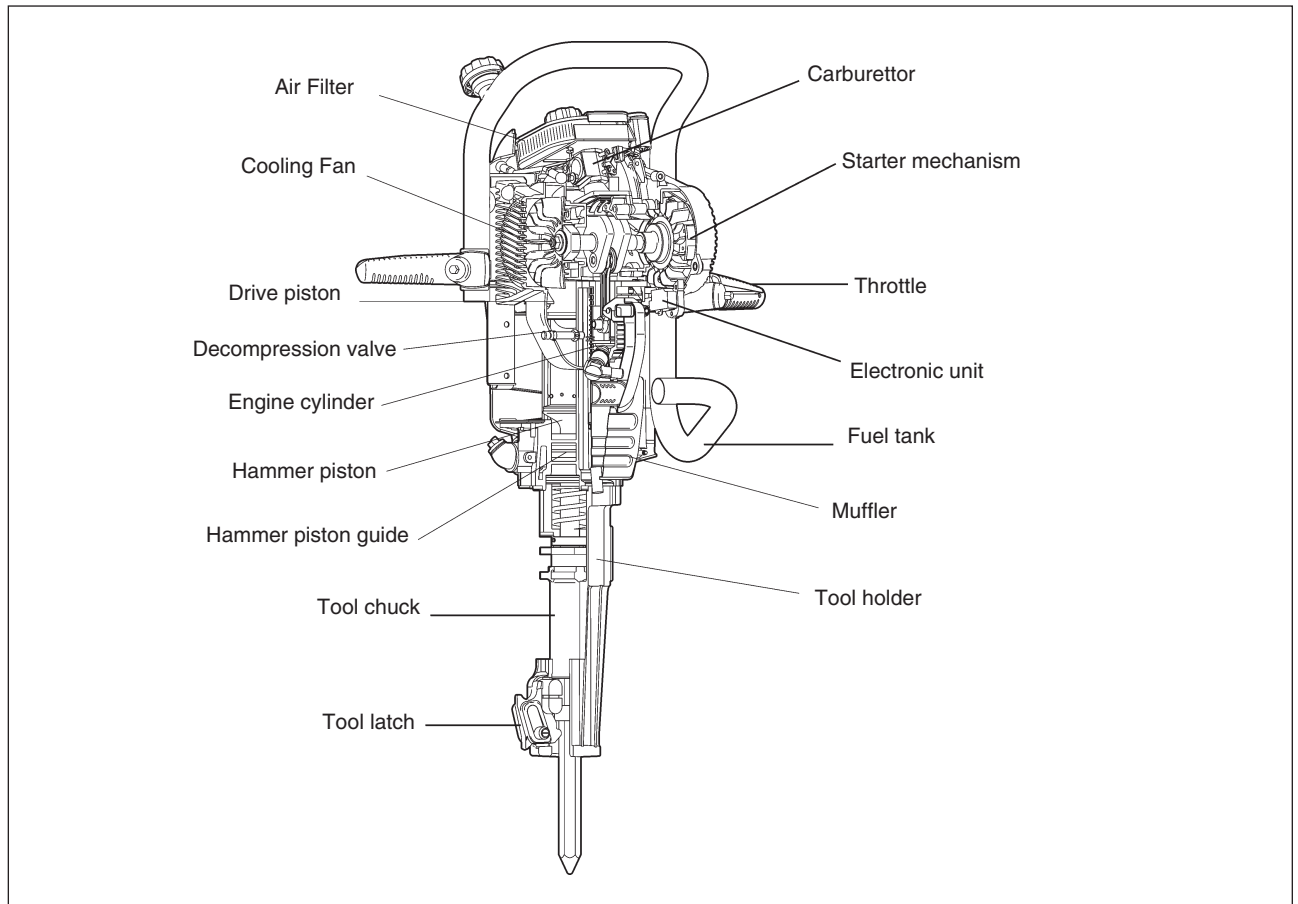

## Engine

The machine is powered by a single-cylinder, air-cooled two-stroke engine. The engine is equipped with a diaphragm carburettor, which is controlled by changes in pressure inside the crankcase.

The carburettor feeds the fuel mixture into the cylinder via a diaphragm valve. The engine is automatically lubricated by the oil in the fuel mixture.

The speed of the engine can be varied by the hand throttle, which is connected to the carburettor butterfly valve.

The maximum speed of the engine is restricted by an electronic speed restrictor, which is incorporated in the breakerless ignition system.

The power transmission between the engine and hammer mechanism is via a gear assembly.

## Hammer mechanism

Before starting the engine, the hammer piston rests on the tool shank. When the engine is started, the drive piston commences to move up and down in the hammer cylinder.





When the handles are pushed down, the tool raises the hammer piston in the hammer cylinder and the hammer mechanism is activated.

When the machine is lifted, the tool drops down onto the tool latch. The hammer piston moves into its lower position, where it stops, and the hammer mechanism is disengaged.

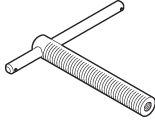
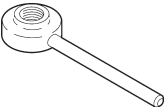
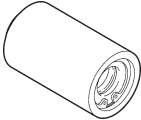

This operational system also means that the machine can stand on a tool without engaging the hammer piston.

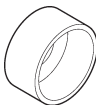
# Service tools

## (Complete set: order number 9234 0003 94)

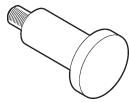
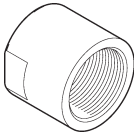
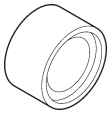
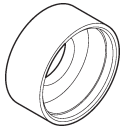
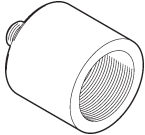
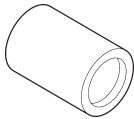
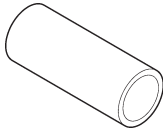
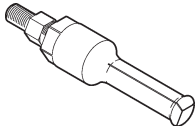
Tool	Order No.	Designation
S1 	9234 0003 58	Puller key
S2 	9234 0003 59	Puller handle
S3 	9234 0003 57	Puller sleeve
S4 	9234 0003 71	Ring
S5 	9234 0003 72	Ring
S6 	9234 0003 68	Ring
S7 	9234 0003 69	Ring

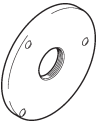
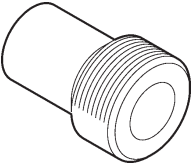
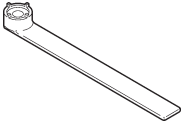
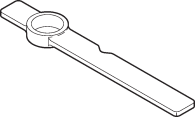
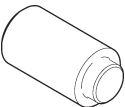
Tool	Order No.	Designation
<p>S8</p> 	<p>9234 0003 84</p>	<p>Tool</p>
<p>S9</p> 	<p>9234 0003 83</p>	<p>Protective bush</p>
<p>S10</p> 	<p>9234 0003 85</p>	<p>Ring</p>
<p>S11</p> 	<p>9234 0003 70</p>	<p>Ring</p>
<p>S12</p> 	<p>9234 0003 81</p>	<p>Tool</p>
<p>S13</p> 	<p>9234 0003 74</p>	<p>Ring</p>
<p>S14</p> 	<p>9234 0003 73</p>	<p>Ring</p>
<p>S15</p> 	<p>9234 0003 93</p>	<p>Puller</p>

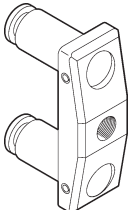
Tool	Order No.	Designation
S16 	9234 0003 86	Ring
S17 	9234 0003 80	Puller
S18 	9234 0003 52	Tool
S19 	9234 0003 49	Tool
S20 	9234 0003 75	Tool
S21 	9234 0003 82	Point
S22 	9234 0003 53	Puller

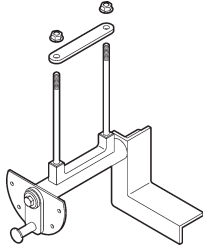
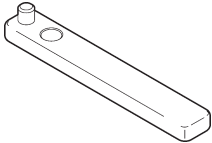
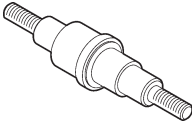
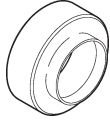
Tool	Order No.	Designation
<p data-bbox="204 174 256 203">S23</p> 	<p data-bbox="863 174 1031 203">9234 0003 66</p>	<p data-bbox="1179 174 1347 203">Engine fixture</p>
<p data-bbox="204 521 256 551">S24</p> 	<p data-bbox="863 521 1031 551">9234 0003 51</p>	<p data-bbox="1179 521 1232 551">Tool</p>
<p data-bbox="204 757 256 786">S25</p> 	<p data-bbox="863 757 1031 786">9234 0004 55</p>	<p data-bbox="1179 757 1232 786">Tool</p>
<p data-bbox="204 992 256 1021">S26</p> 	<p data-bbox="863 992 1031 1021">9234 0004 57</p>	<p data-bbox="1179 992 1232 1021">Ring</p>

# Engine covers

## Dismantling of the machine

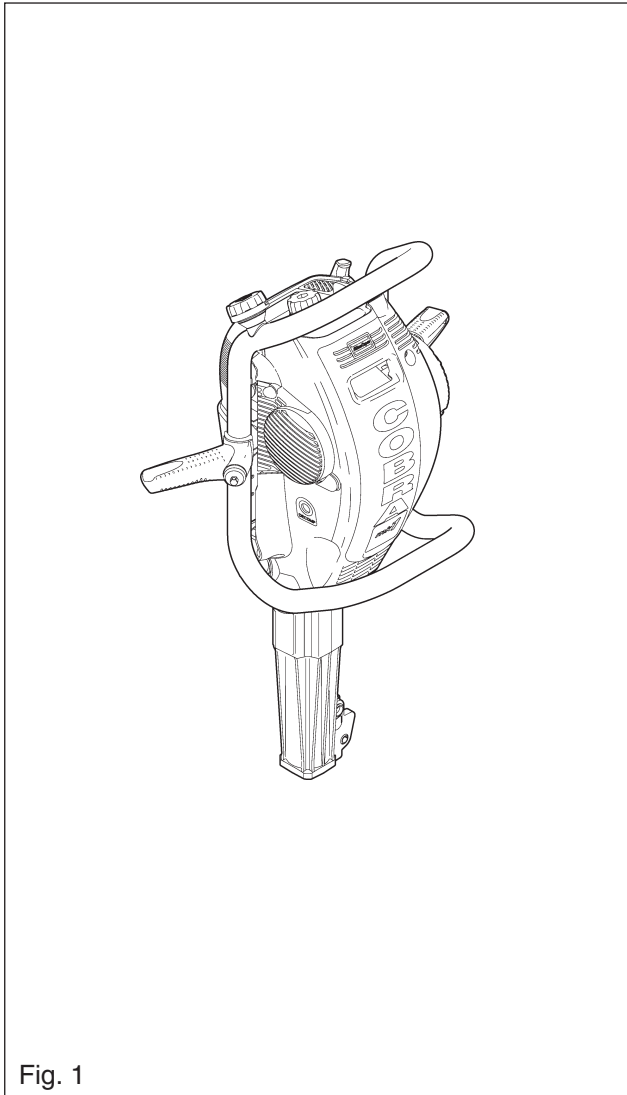

### General

Follow the instructions in this handbook carefully.

Use the tools listed under the heading "Service tools" on pages 9-12.

To avoid injury, always allow the machine to cool down before service.

Always clean all loose dirt carefully from the machine before servicing is carried out. Wash the parts in paraffin or a similar solvent. Do not use corrosive acids, as this may cause damage to certain components.

Empty the fuel tank to prevent petrol from leaking out.

Empty the oil from the hammer cylinder.

Remove the spark plug.

Spare part numbers are provided in a separate spare parts list.

Use only Atlas Copco original spare parts.

## Dismantling of the covers

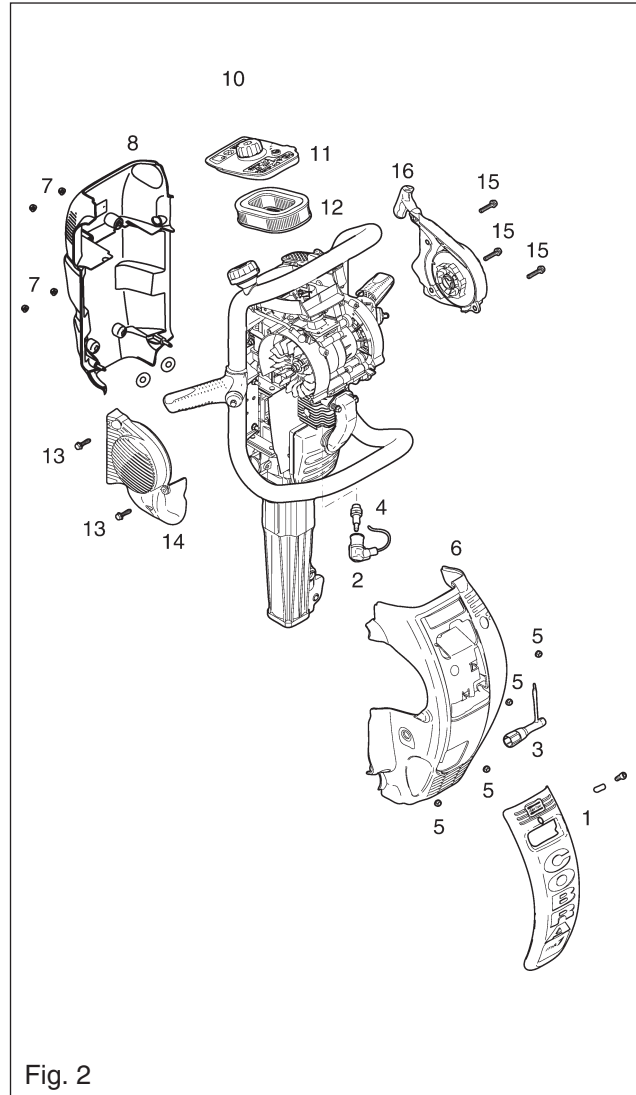

### Service cover

Dismantle the service cover (1) from the machine. Pull the ignition cable (2) from the spark plug (4) and use the spark plug spanner (3) to remove the spark plug.

Clean the electrodes with a steel brush and adjust the electrode gap to 0.6-0.7 mm.

**Note:** To guarantee reliable starting and running, the spark plug must be checked every week and replaced after 50 hammering hours.

### Front cover

Remove the four nuts (5), push down the fuel tank, and lift out the front cover (6).

Examine the cover for damage or cracks, and replace if necessary.

### **Rear cover**

Remove the four nuts (7) and lift off the rear cover (8). Examine the cover for damage or cracks, and replace if necessary.

### **Filter cover**

Undo the filter cover knob (10) and take off the filter cover (11).

Lift out the air filter (12) from the filter housing. Examine the condition of the filter. If it is dirty, it must be replaced.

**Note:** Do not use compressed air to clean the air filter, as it may damage the paper insert.

The air filter should be replaced after 70 hours' use. In extremely dirty conditions, e.g. when working with concrete, the filter should be examined at least twice a day and cleaned or replaced as required.

**Note:** A dirty or choked filter will impair the performance of the machine and will increase wear in its internal parts.

### **Fan cover**

Remove the two screws (13) holding the fan cover (14) and lift off the cover. Examine the cover for cracks, and replace if necessary.

### **Starter cover**

Remove the three screws (15) and lift off the starter cover (16).

# Starter mechanism

## Replacing starter rope with starter pulley in place

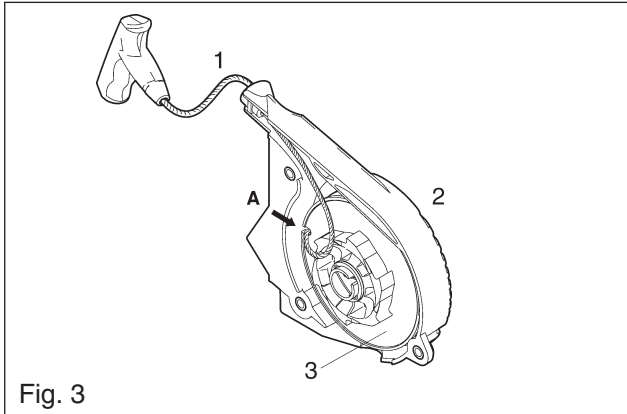

### Dismantling

The engine starter rope can be replaced without removing the starter pulley (3).

Pull out about 40 cm of rope (1) from the cover (2), and lay the rope in the notch (A) in the starter pulley (3), see Fig. 3.

Release the spring tension by rotating the starter pulley clockwise until there is no longer any spring tension.

Use a pair of pliers to pull out the rope knot from the starter handle (1). Cut off the knot and pull the rope out from the handle.

Using a pair of pliers pull out the rope knot from the pulley wheel (2) and remove the rope completely.

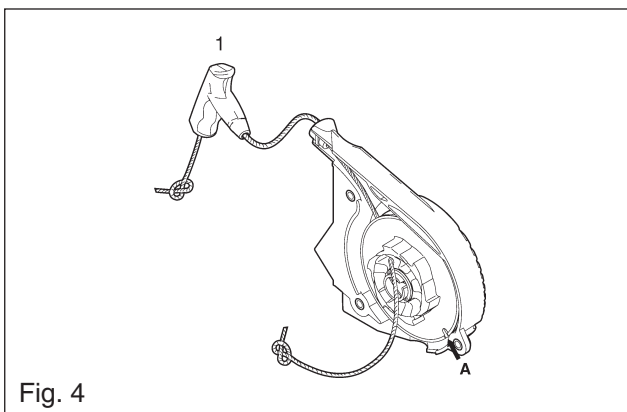

### Reassembly

Rotate the starter pulley anticlockwise until the hole in the starter pulley aligns with the rope bush in the starter cover.

Pass a new rope through the hole in the starter pulley and on through the rope bush in the cover.

Pass the rope through the handle, and make a knot at the end of the rope. Pull the knot back into the handle. Turn the starter pulley anticlockwise until the notch (A) aligns with the rope bush in the cover

Pull out the rope and lay it in the notch. Rotate the starter pulley anticlockwise for five turns. Support the starter pulley securely.

Take the rope from the notch, release the starter pulley and allow the rope to wind up slowly.

**IMPORTANT!** Check the spring tension by pulling the starter rope out to its full extent. It must then be possible to rotate the starter pulley for a further half turn anticlockwise.

If this is not possible, the spring is over-tensioned and the spring tension must be released by one turn.

## Replacement of starter rope, starter pulley and spring.

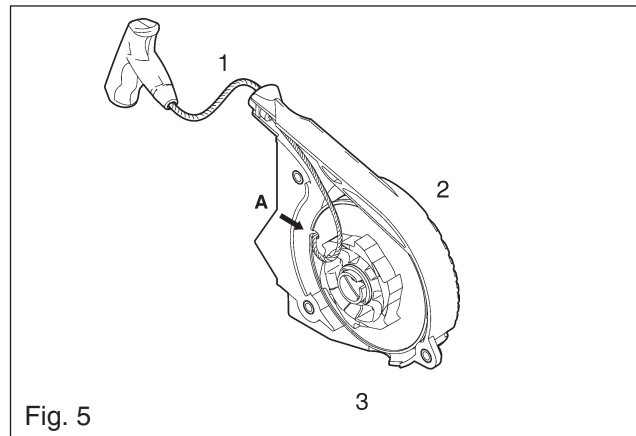

Pull out about 40 cm of the rope (1) from the cover (2), and place the rope in the notch (A) on the starter pulley (3). See Fig. 5.

Release the spring tension by rotating the starter pulley clockwise until there is no longer any spring tension.

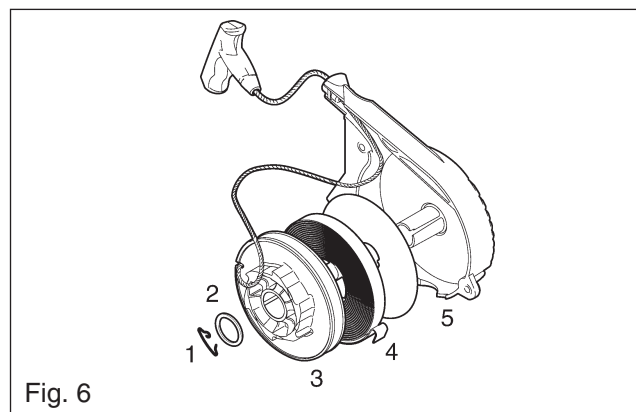

Remove the locking ring (1) and the washer (2), and lift the starter pulley (3) from the starter cover.

Carefully lift the starter spring (4) from the starter pulley. Examine the condition of the starter spring and replace if the hooks are damaged or worn.

Examine the starter pulley teeth for wear, and replace the pulley if they are damaged or worn. Remove the washer (5), examine it for wear or damage and replace if necessary.

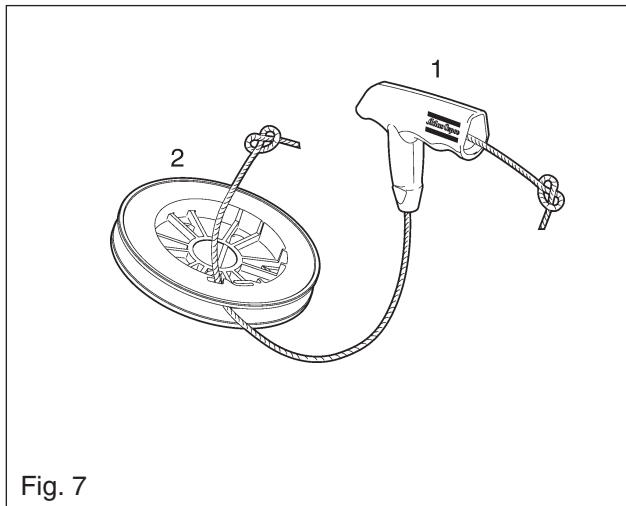

Using a pair of pliers, pull out the knot from the starter handle (1). Cut off the knot and pull the rope out from the handle.

Examine the handle, which must be replaced if it is worn or has cracks. Using a pair of pliers, pull out the rope knot from the pulley wheel (2) and remove the rope completely.

Examine the rope and replace it if worn.

**Note:** Always wear protective gloves and protective glasses when reassembling or dismantling the starter spring.

## Reassembly of starter mechanism

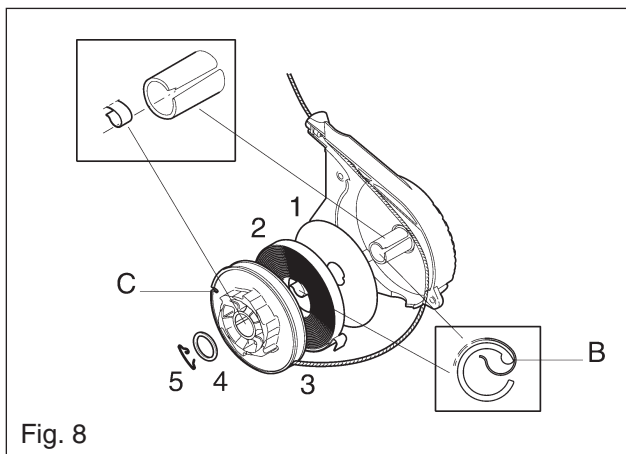

Locate the washer (1) on the starter cover.

Fit the starter spring (2) in the starter pulley (3). Engage the spring hook (A) in the groove (D) in the starter pulley and wind up the spring anticlockwise, at the same time guiding it into place in the starter pulley; see Fig. 9.

**Note:** Always wear protective gloves and protective glasses when reassembling or removing the starter spring.

Wind the rope anticlockwise onto the starter pulley. Leave about 5 cm of rope outside the cover. Engage the spring hook (B) in the notch on the starter cover and press the starter pulley into place.

Fit the washer (4). Refit the locking ring (5) and check that it is correctly engaged in the groove.

Pull out the rope for approximately 40 cm. Place the rope in the notch (C) and rotate the starter pulley (3) one turn anticlockwise. Let the cord wind slowly onto the starter pulley.

**IMPORTANT!** Check the spring tension by pulling the starter rope out to its full extent. It must then be possible to rotate the starter pulley for a further half turn anticlockwise. If this is not possible, the spring is over-tensioned and the spring tension must be released by one turn.

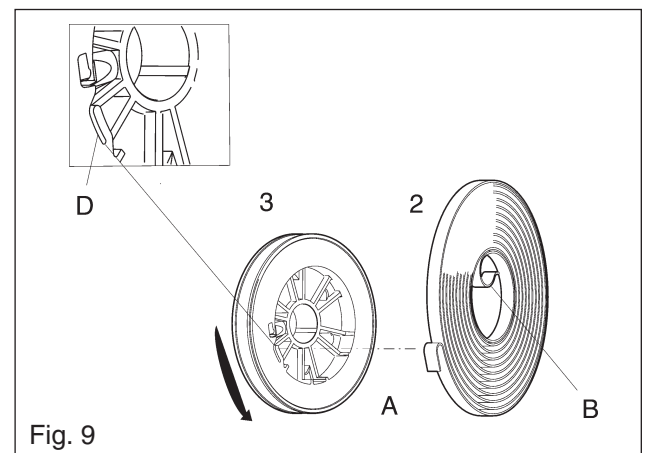

# Filter housing and carburettor

## Dismantling of filter housing

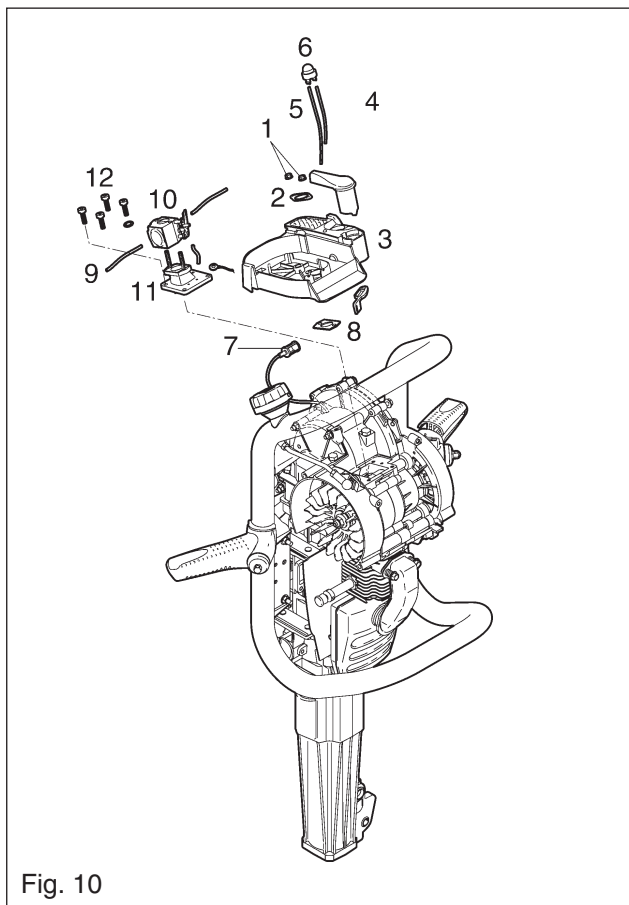

Fig. 10

Undo the two nuts (1) and remove the flat washer (2).

Lift up the filter housing (3) and disconnect the hoses (4) and (5) from the venting pump.

Remove the crankcase ventilation filter (7) from its mounting on the filter housing, and lift the housing from the machine.

Disconnect the venting pump (6) from the filter housing. Examine the pump or the hoses for cracks, and replace if necessary.

## Dismantling and reassembly of choke control and lever

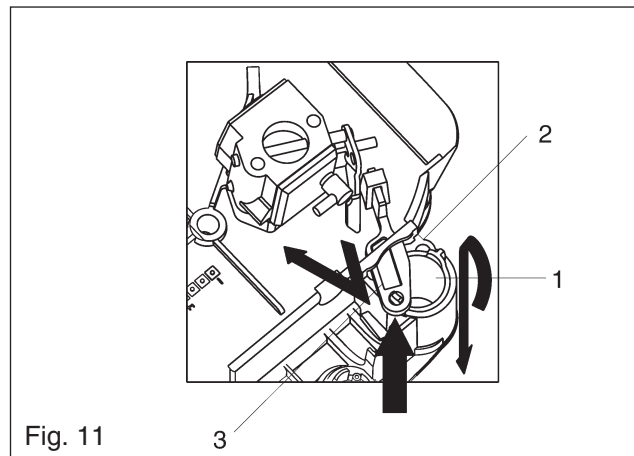

Fig. 11

Rotate the choke control so that the locking pin engages in the groove on the filter housing (2).

Pull out the choke control from the housing. Examine it for wear, and replace if necessary.

Dismantle the choke lever arm (3) from the housing and examine it for wear. Replace if necessary. Reassembly is in the reverse sequence.

## Dismantling of carburettor and diaphragm valve, Fig. 10

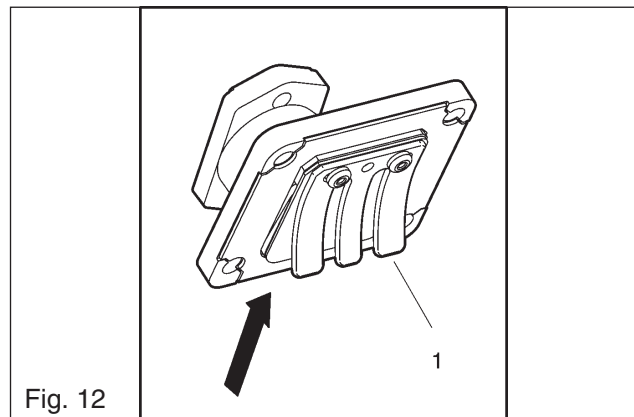

Fig. 12

Remove the carburettor gasket (8) and the fuel pipe (9) from the carburettor (10). Unhook the throttle cable from the carburettor cable wheel and lift off the carburettor from the diaphragm valve (11).

Unhook the throttle cable from the carburettor cable wheel and lift off the carburettor from the diaphragm valve (11) housing and the diaphragm for wear, see Fig. 12, and replace if necessary.

**Note:** The position of the supporting legs (1) must not be changed, as this will impair the performance of the engine.

# Engine and hammer mechanism

## Dismantling of muffler, stabilizer brace and engine mounting bolts

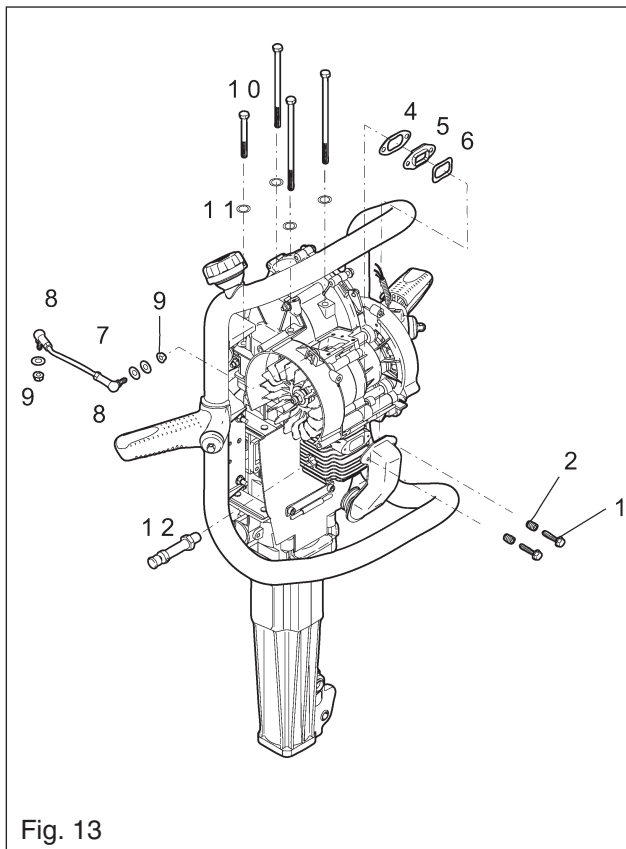

Fig. 13

Remove the screws (1) and the springs (2).

Pull back the muffler and remove the seals (4, 6) and the insert (5). Discard the seals. Clean any deposits from the insert.

Undo the nuts (9) and remove the stabilizer brace (7). Examine the two ball joints for wear (8). Replace them if they are worn or damaged.

Remove the four engine mounting bolts (10) and their washers (11).

Dismantle the decompression valve (12). Clean any deposits from the valve seat and the cylinder channel. Replace the valve if it is leaking.

Release and unscrew the throttle cable adjuster screw from the crankcase.

## Dismantling of the engine from the machine

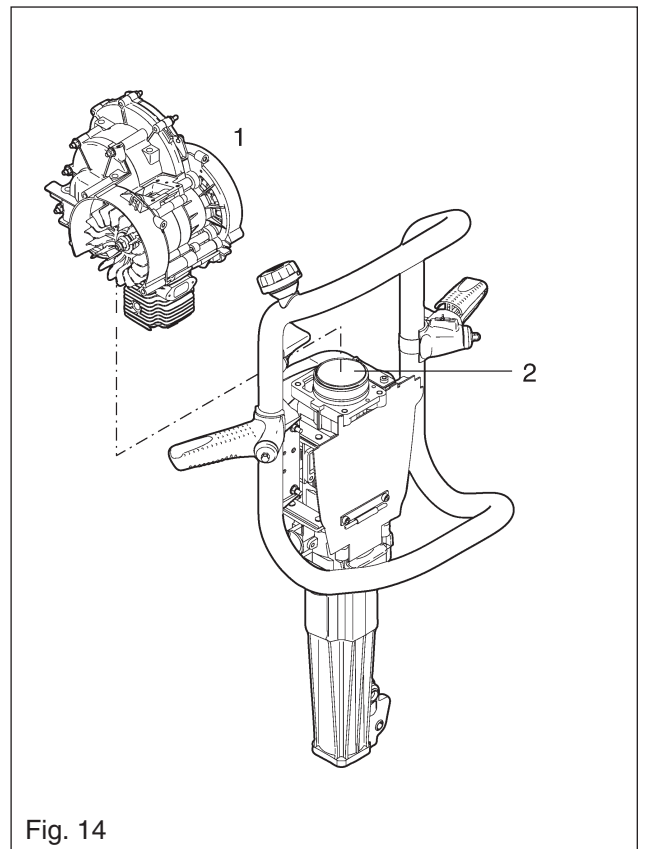

Fig. 14

Lift up the engine (1) from the hammer cylinder (2), supporting the drive piston at all times to prevent it from being damaged.

## Dismantling of the muffler, heat shield and fuel tank

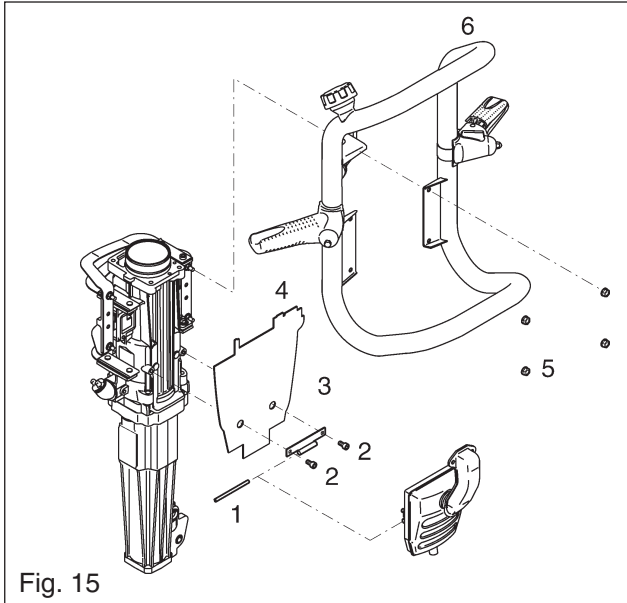

Fig. 15

Tap out the spring pin (1) using a suitable drift, and lift the muffler from the machine.

Remove the screws (2) and take off the holder (3).

Remove the heat shield (4) and examine it for cracking or damage. Replace if necessary.

Remove the nuts (5) and lift the fuel tank (6) from the machine. Examine the fuel tank for damage, and replace if necessary.

## Dismantling of the anti-vibration springs

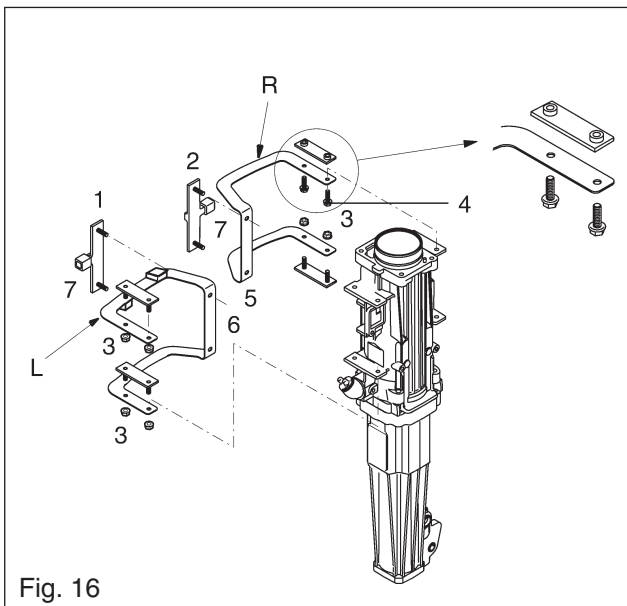

Fig. 16

Remove the two end stops (1) and (2). The end stops are interchangeable.

Remove the plastic bushes (7) and replace them with new ones.

Remove the six nuts (3) and the two screws (4) from the hammer cylinder.

**Note:** The top left-hand pressure plate has captive nuts and is secured with two screws. The three other plates have captive screws and are held in place with nuts.

Remove the right-hand (5) and the left-hand (6) leaf springs.

Examine the springs; if they are cracked or damaged, they must be replaced.

**Note:** The springs are not interchangeable.

## Dismantling of the tool holder

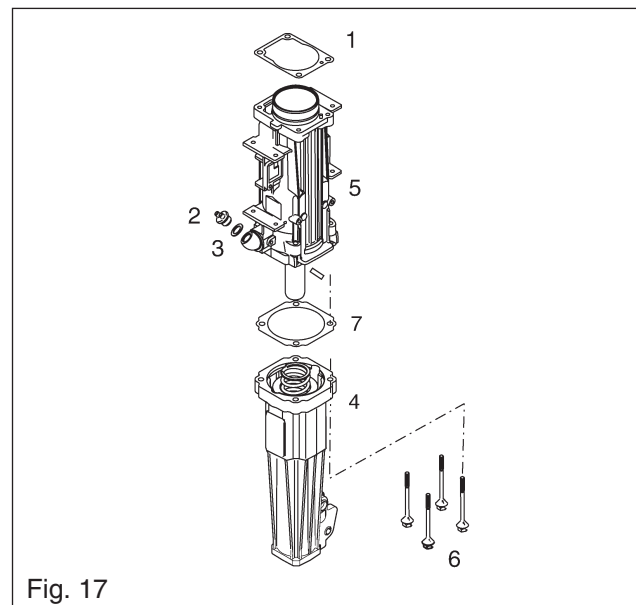

Fig. 17

Remove the gasket (1) and discard it.

Remove the oil plug (2) and drain the oil from the cylinder.

Examine the O-ring (3), and replace if necessary.

Remove the four screws (6) and lift the tool holder (4) from the hammer cylinder (5).

Remove the gasket (7) and discard it.



## Dismantling and reassembly of the hammer piston and hammer piston guide

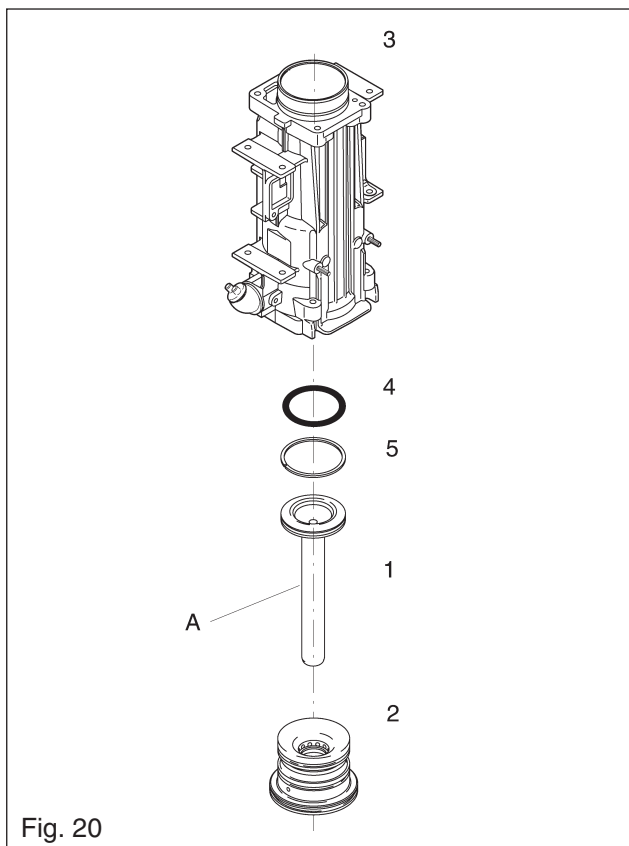

Fig. 20

### Dismantling

Dismantle the hammer piston (1) together with the hammer piston guide (2) from the hammer cylinder (3).

Withdraw the piston from the piston guide, and dismantle and discard the piston ring (5) and the O-ring (4).

Examine the condition of the groove.

**Note:** When replacing the piston ring and O-ring of the hammer piston, the piston ring and O-ring of the drive piston should be replaced at the same time.

Examine the hammer surface (A) for wear.

Examine the condition of the piston rod and flange of the piston, and replace them if there are any scratches or signs of cracking.

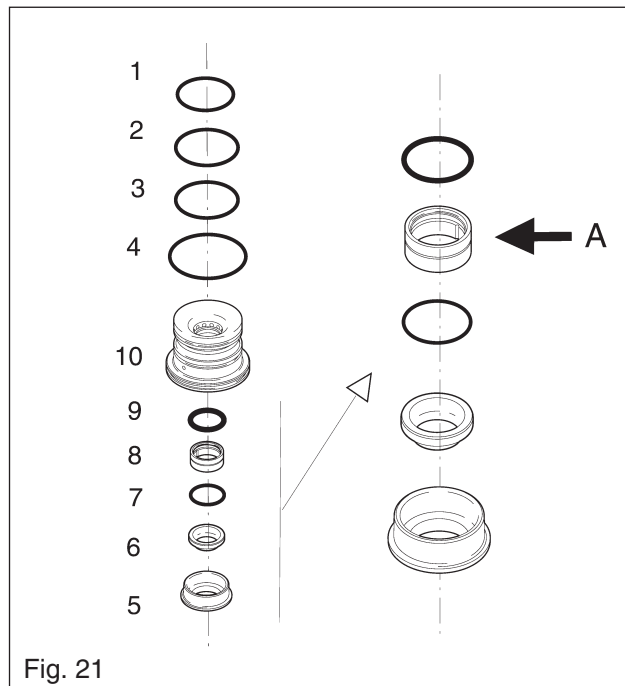

Fig. 21

Remove and discard the O-rings (1), (2), (3) and (4), support ring (5) and scraper ring (6) of the hammer piston guide (10).

Tap a sharp screwdriver into the locking ring (7) without damaging the groove in the guide. Bend out and remove the locking ring, which must be discarded after removal.

Dismantle and discard the sealing ring (8) and the O-ring (9).

### Reassembly

Fit a new O-ring (9) and sealing ring (8).

**Note:** Check the direction (A) of the sealing ring (8).

Locate service tool S26 in the piston guide. Fit a new locking ring (7) in the tool, and tap the locking ring down into the piston guide with service tool S20.

Check that the locking ring is correctly engaged in the groove.

Fit new O-rings (1), (2), (3) and (4), and a new support ring (5) and scraper ring (6).

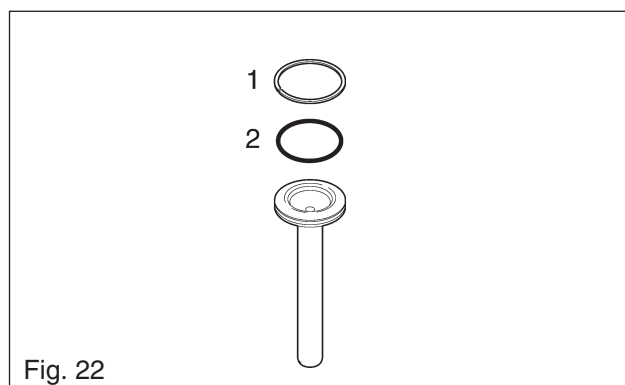

Fig. 22

Fit a new piston ring (1) and O-ring (2) to the hammer piston. Lubricate the piston rod and insert it into the hammer piston guide.

## Dismantling of the drive piston

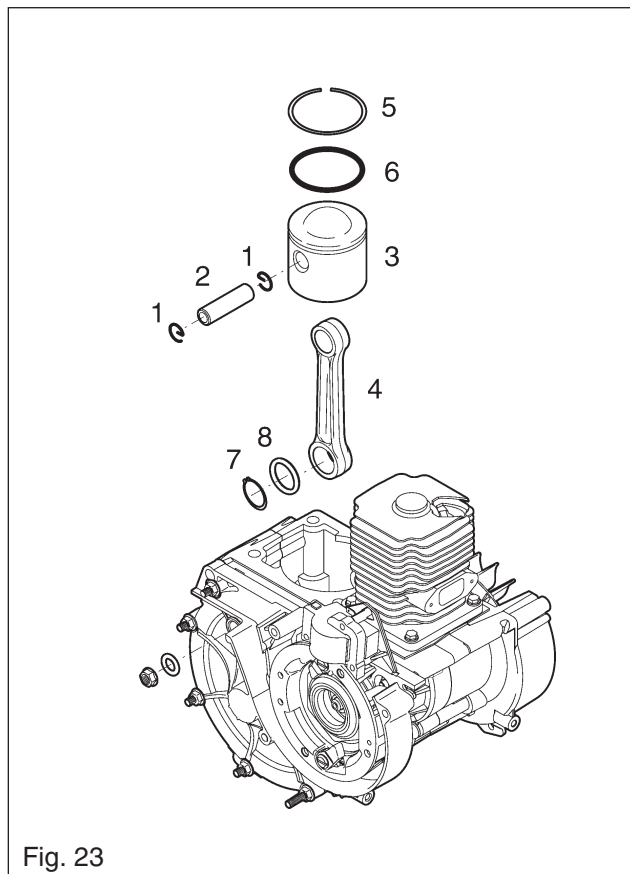

Fig. 23

Remove and discard the locking rings (1).

Use a suitable drift to press out the gudgeon pin (2), supporting the connecting rod and the piston at all times.

Lift the piston (3) from the connecting rod (4). Remove and discard the piston ring (5) and the O-ring (6).

Examine the grooves and the surfaces of the piston, and replace if damaged or worn.

Dismantle the locking ring (7) and the washer (8); the locking ring must be discarded. Lift the connecting rod (4) from the hammer piston crankshaft.

## Dismantling and reassembly of the connecting rod bearings

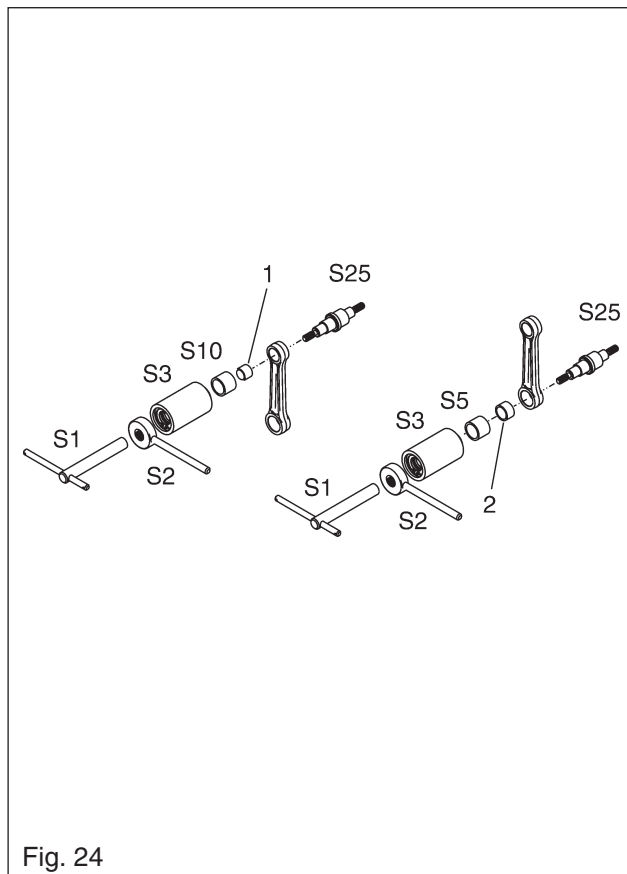

Fig. 24

Dismantle the needle bearing (1) using service tools S1, S2, S3, S10 and S25.

Fit a new bearing using service tools S1, S2, S3 and S25.

Dismantle the needle bearing (2) using tools S1, S2, S3, S5 and S25.

**Note:** Once it has been dismantled, a needle bearing must not be re-used and must be discarded.

## Dismantling of plastic bushes

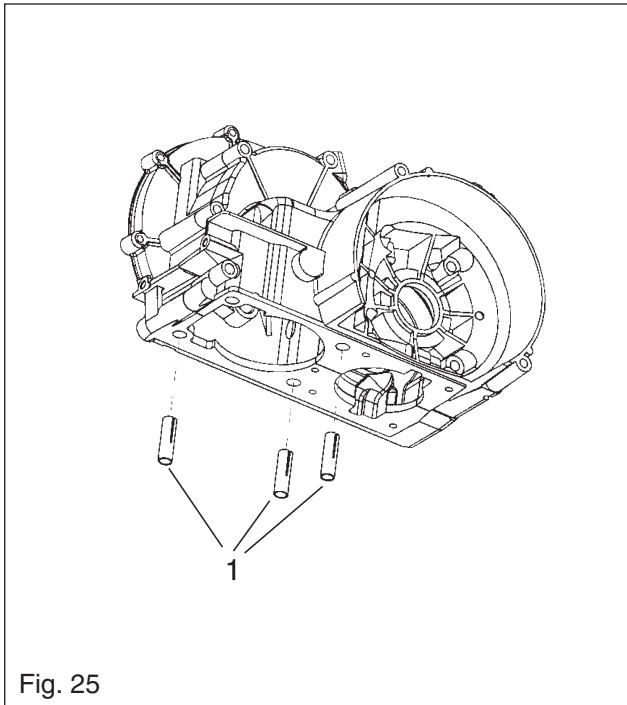

Fig. 25

Dismantle and discard the three plastic bushes (1).

## Mounting the engine on the fixture

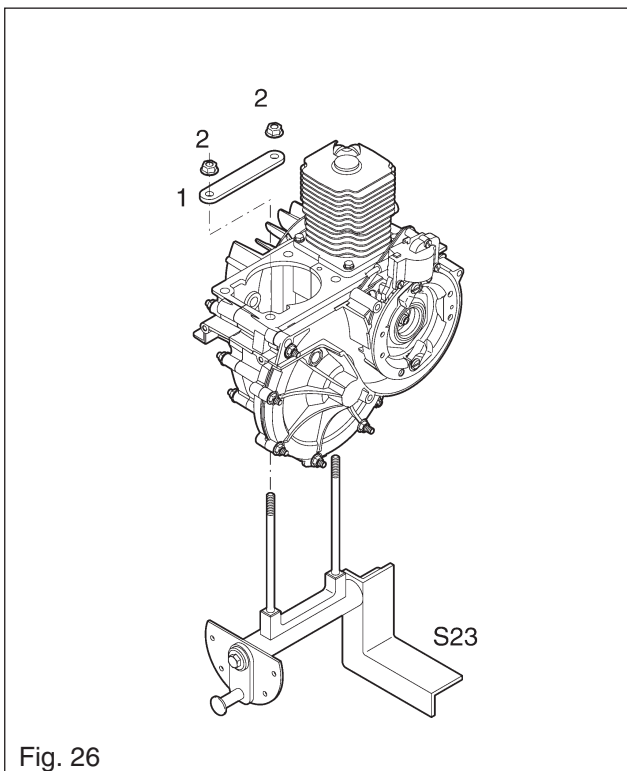

Fig. 26

Place fixture S23 securely in a swivel vice.

Lift the engine onto the fixture and lock it in place with the plate (1) and the nuts (2).

## Dismantling of the cooling fan

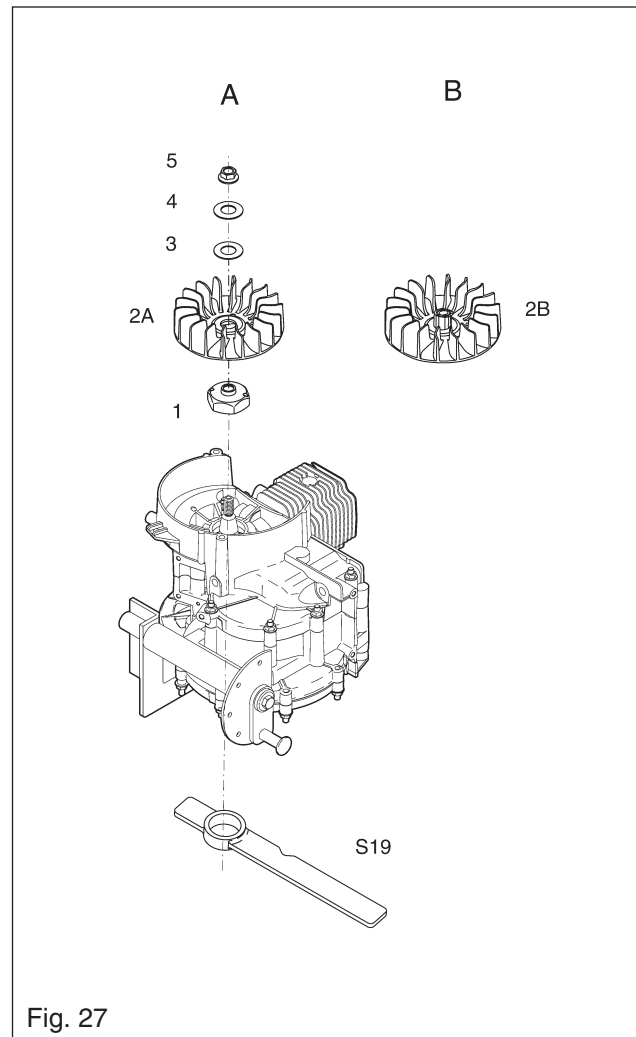

Fig. 27

### Type A

Lock the flywheel using service tool S19 and dismantle the nut (5), the spring washer (4) and the flat washer (3). Lift the fan from the hub (1).

Use a suitable puller to remove the hub (1) from the crankshaft taper.

Examine the fan blades; if they are damaged or worn, the fan must be replaced.

### Type B

Lock the flywheel using service tool S19 and remove the fan.

Examine the fan blades, the taper and the thread; if they are worn or damaged, the fan must be replaced.



## Dismantling of the transmission cover

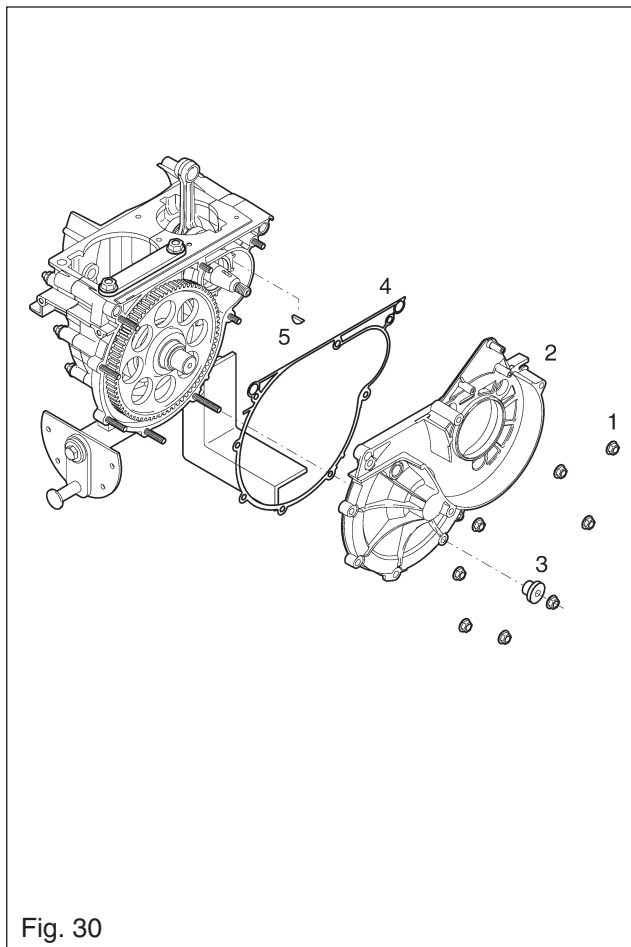

Fig. 30

Remove the eight nuts (1).

**Note** the position of the supporting bush (3) for the filter cover.

Place a flat-bladed screwdriver in one of the notches that are present on both sides of the transmission cover (2) and carefully lever off the cover.

Dismantle and discard the gasket (4).

Clean the sealing surfaces using a wooden or plastic scraper.

Remove the Woodruff key (5), and always replace it with a new one if it is scratched or damaged.

## Dismantling of the fan side crankcase

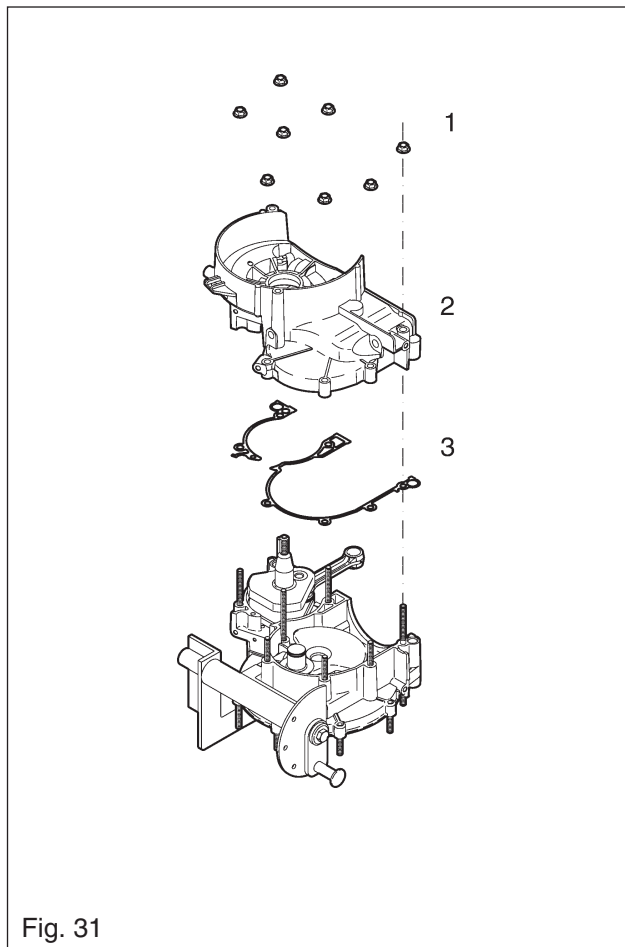

Fig. 31

Remove the eight nuts (1).

Place a flat-bladed screwdriver in one of the notches that are present on both sides of the crankcase half and carefully lever off the cover.

Remove and discard the gasket (3).

Clean the sealing surfaces using a wooden or plastic scraper.

## Dismantling of the hammer crankshaft gear wheel

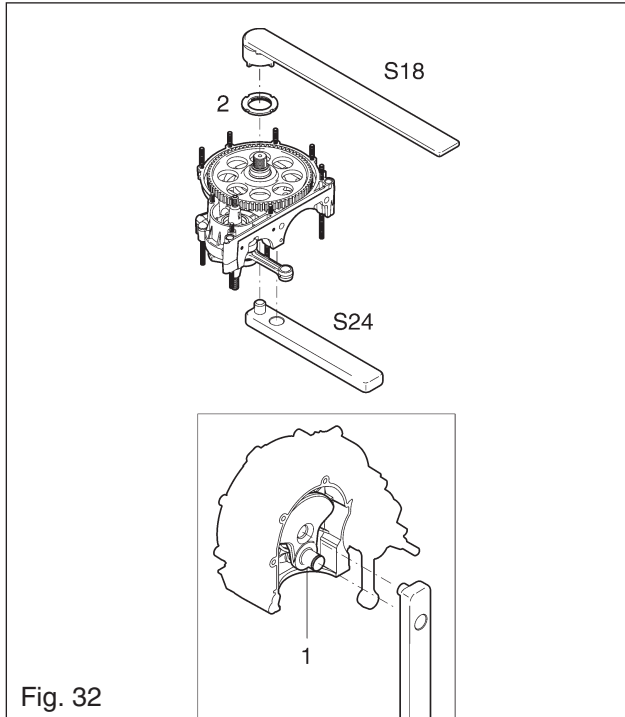

Fig. 32

Dismantle the engine from fixture S23. Fix service tool S24 in the swivel vice.

Place the pin of the tool in the hole in the hammer crankshaft.(1).

Use tool S18 to remove the nut (2).

**Note:** The nut has a left-hand thread.

## Dismantling of the hammer crankshaft

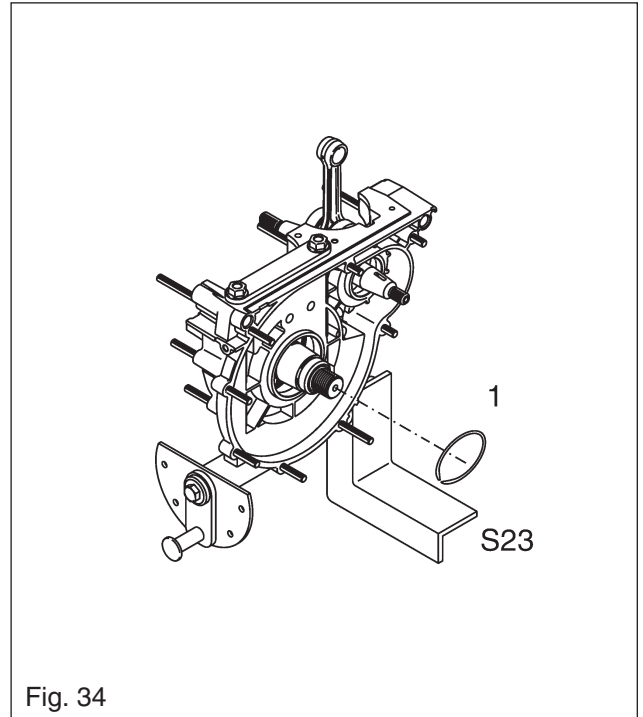

Fig. 34

Fix the engine half in fixture S23.

Dismantle the locking ring (1).

The locking ring is deformed during removal and must be discarded.

**Note:** A groove is present in the crankshaft to facilitate removal.

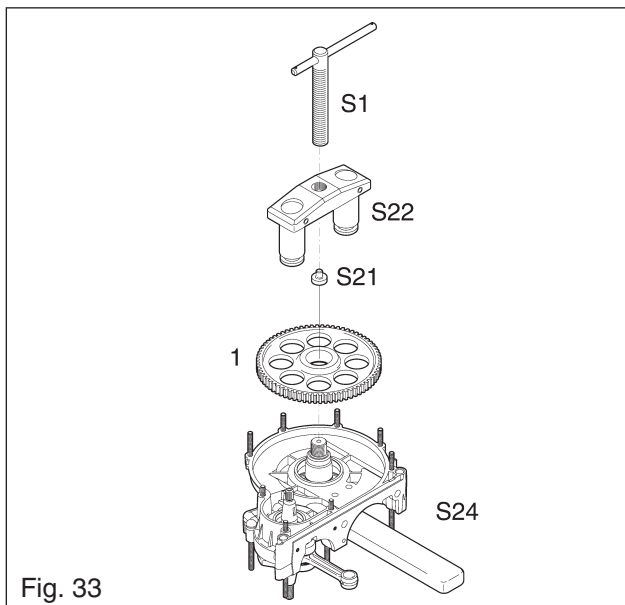

Fig. 33

Dismantle the gear wheel (1) using tools S1, S21 and S22. Examine the gear teeth for wear; the gear wheel must be replaced if they are worn or damaged.

**Note:** If the hammer crankshaft gear wheel is replaced, the engine crankshaft gear wheel must also be replaced.

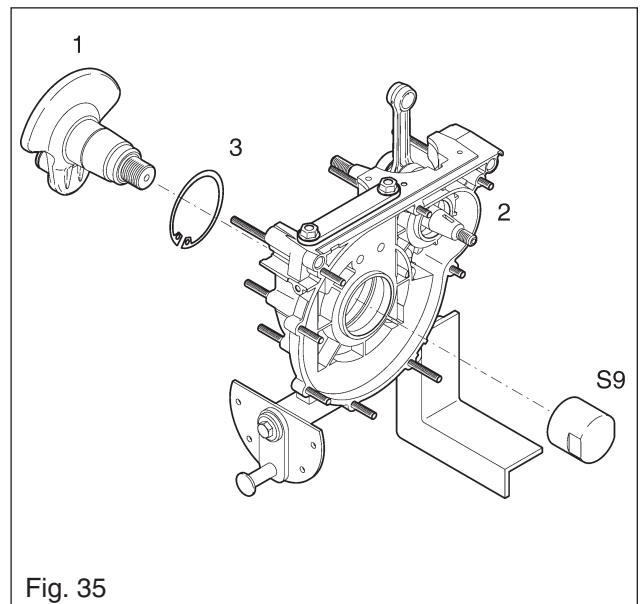

Fig. 35

Dismantle the locking ring (3).

Fit service tool S9 on the hammer crankshaft (1).

Use a rubber hammer to knock out the hammer crankshaft from the crankcase half (2).

## Dismantling of the hammer crankshaft bearing

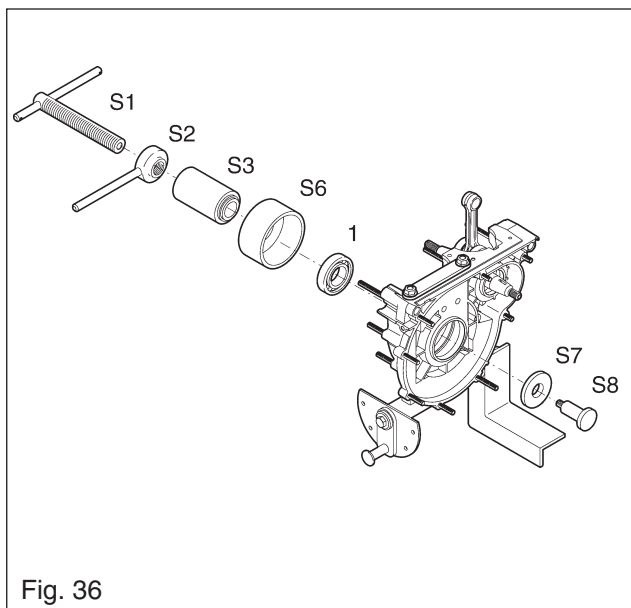

Fig. 36

Use service tools S1, S2, S3, S6, S7 and S8 to dismantle the bearing (1).

The bearing must be discarded after removal.

## Dismantling and reassembly of the engine crankshaft bearing and seal

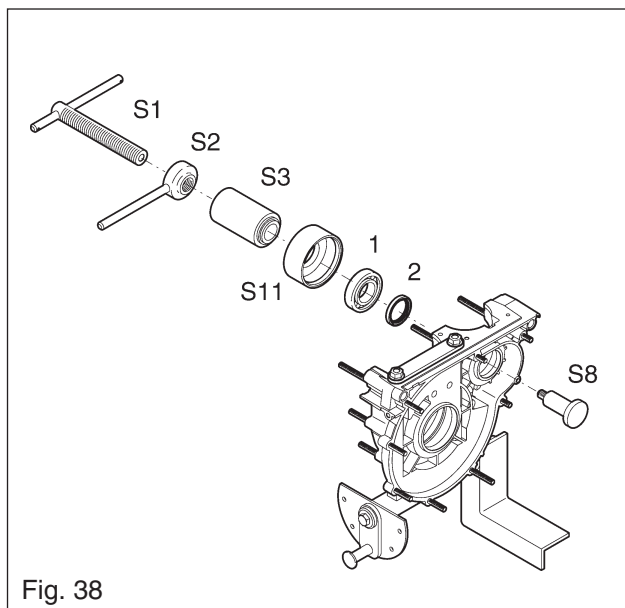

Fig. 38

### Dismantling

Use service tools S1, S2, S3, S8 and S11. Dismantle and discard bearing (1) and seal (2).

## Dismantling of the engine crankshaft

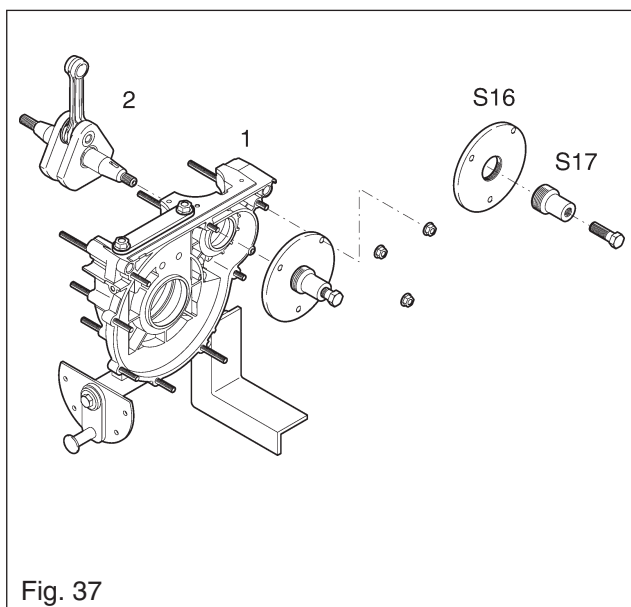

Fig. 37

Fix service tool S16 to the crankcase half (1).

The tool must be fitted to the existing studs.

Screw tool S17 into tool S16.

Tighten the puller tool screw and push out the crankshaft (2).

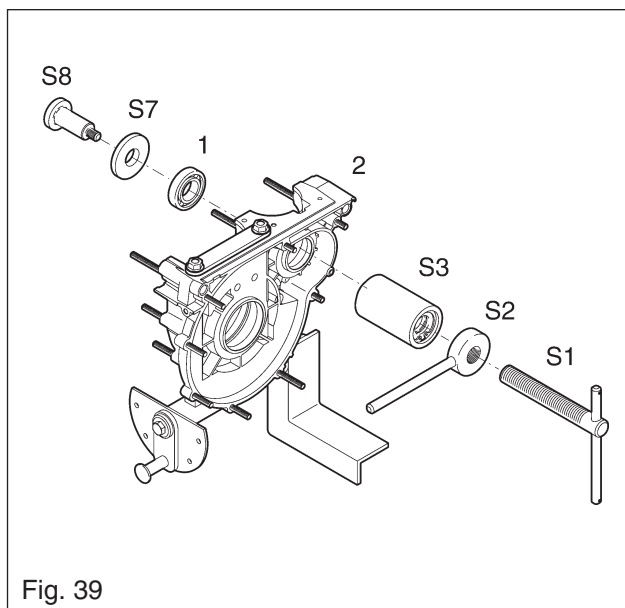

Fig. 39

### Reassembly

Use service tools S1, S2, S3, S7 and S8 to fit a new bearing (1) in the crankcase (2).

## Reassembly of engine crankshaft

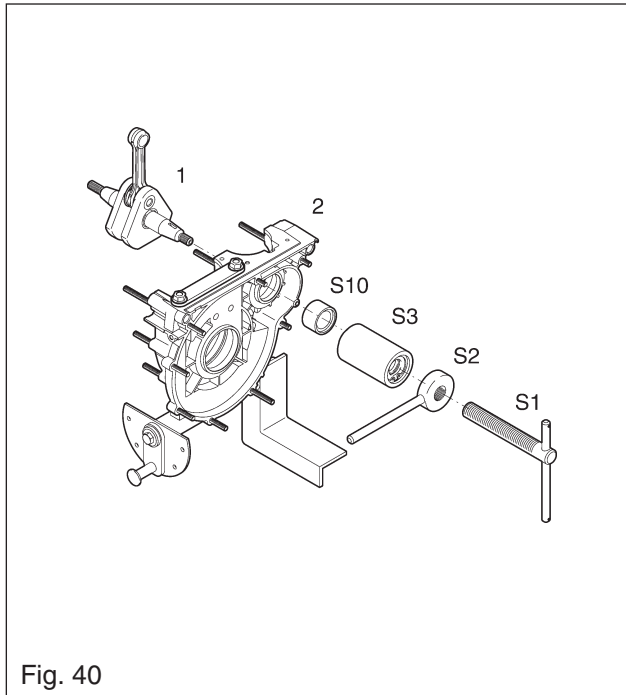

Fig. 40

Fit the crankshaft (1) in the crankcase (2) using service tools S1, S2, S3 and S10.

## Reassembly of hammer crankshaft bearing

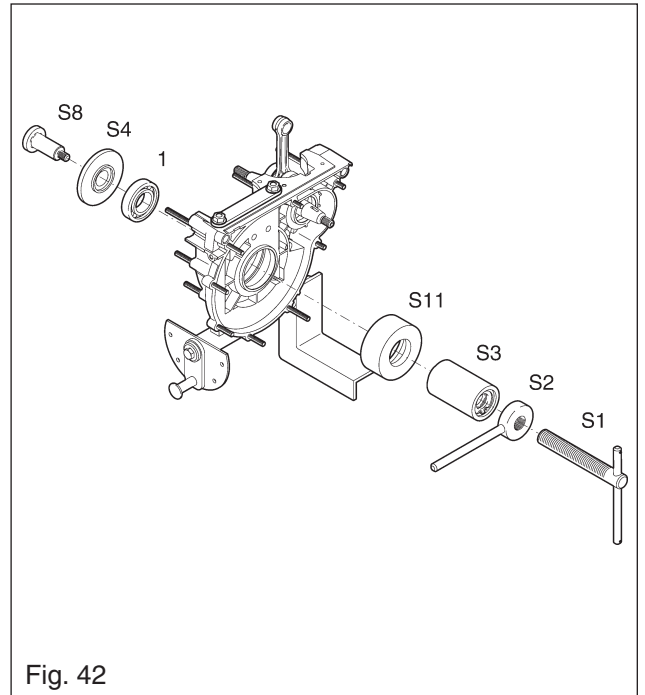

Fig. 42

Fit a new bearing (1) in the crankcase using service tools S1, S2, S3, S4, S8 and S11.

## Reassembly of crankshaft seal

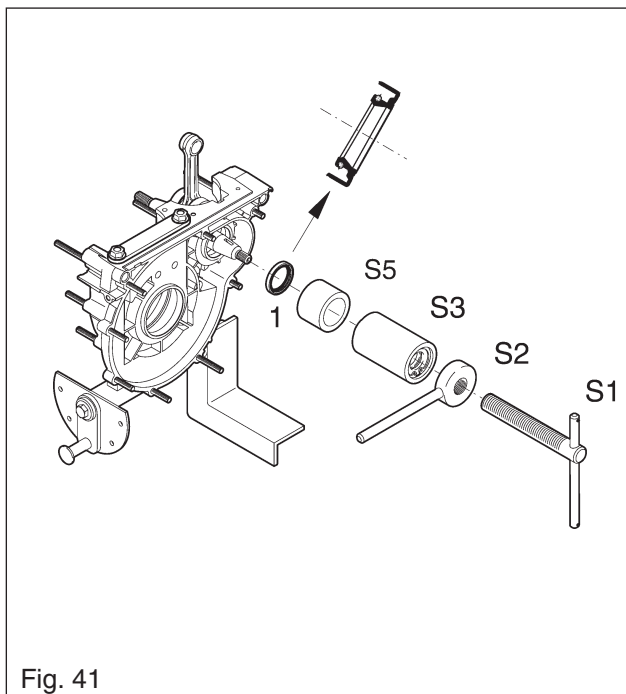

Fig. 41

Fit a new seal (1) in the crankcase using service tools S1, S2, S3 and S5.

**Note:** Check the direction of the seal.

## Reassembly of locking ring

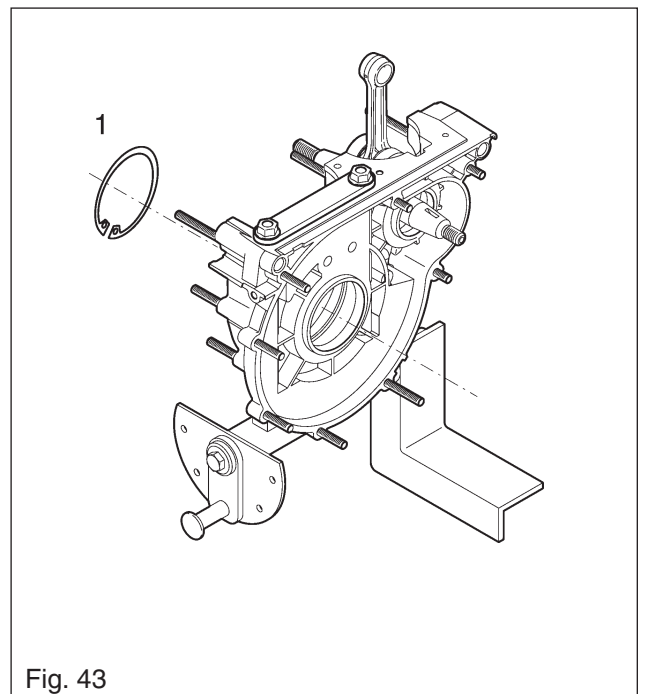
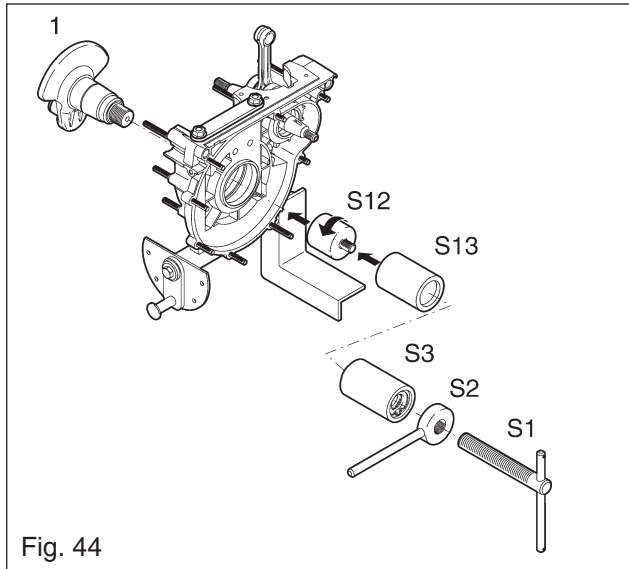

Fig. 43

Fit the locking ring (1).

Check carefully that the locking ring is correctly seated in the groove.

## Reassembly of hammer crankshaft



Fit the hammer crankshaft (1) in the crankcase using service tools S1, S2, S3, S12 and S13.

## Reassembly of locking ring on hammer crankshaft

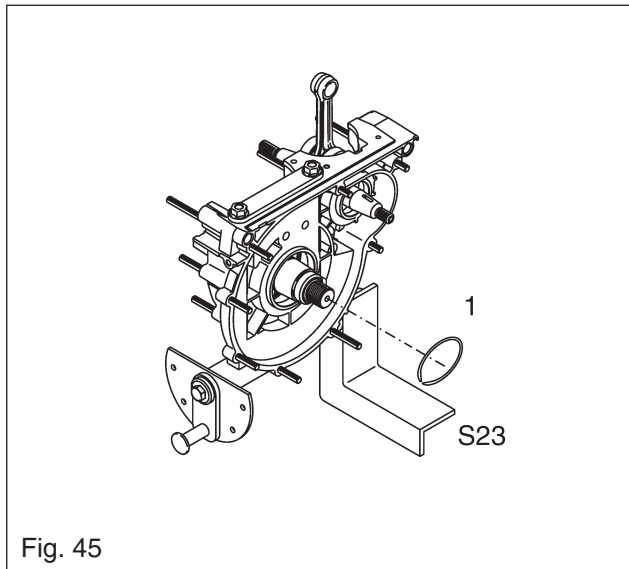

Fit a new locking ring on the hammer crankshaft. Check carefully that the locking ring is correctly seated in the groove.

## Reassembly of hammer crankshaft gear wheel

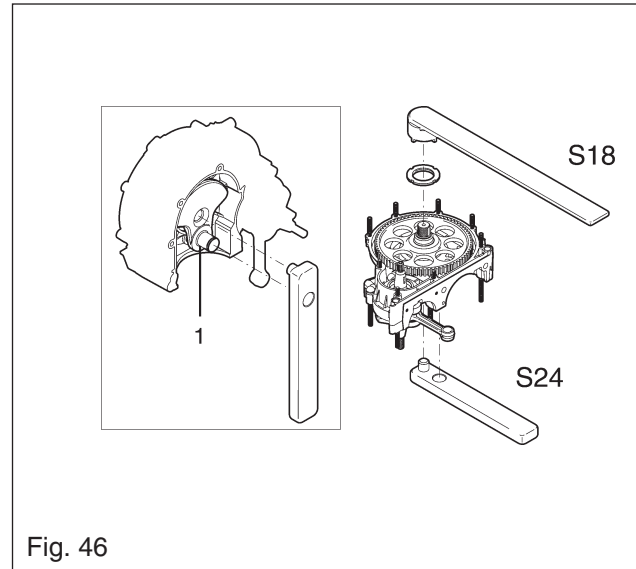

Dismantle the engine crankcase from the fixture S23. Fix service tool S24 in the swivel vice. Locate the pin of the tool in the hole on the hammer crankshaft.

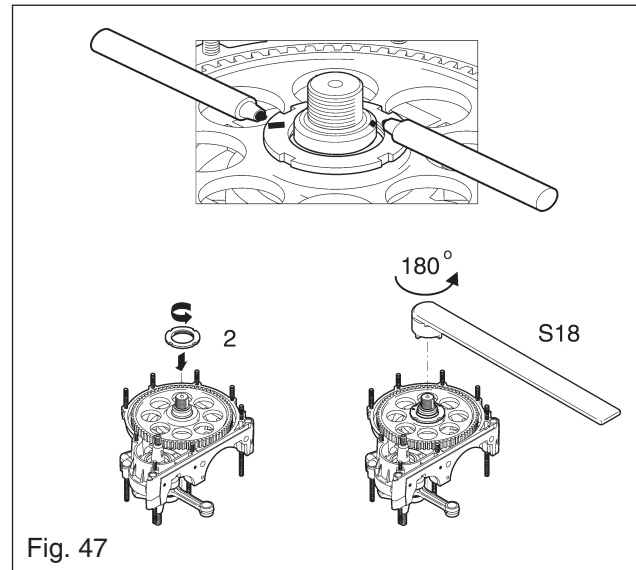

Degrease the hammer crankshaft and gear wheel taper with a suitable degreasing agent. Both tapers must be totally clean and free from grease to ensure a secure grip between the gear wheel and the crankshaft. Thread on the nut (2) and tighten it by hand until the nut makes contact with the gear wheel. **Note:** The nut has a left-hand thread. Make a mark on the nut (2) with a marker pen and another mark on the other side on the end of the crankshaft. Use tool S18 to tighten the nut by half a turn (180°), i.e. until the markings are directly in line with one another.

## Dismantling of transmission cover needle bearing and seal

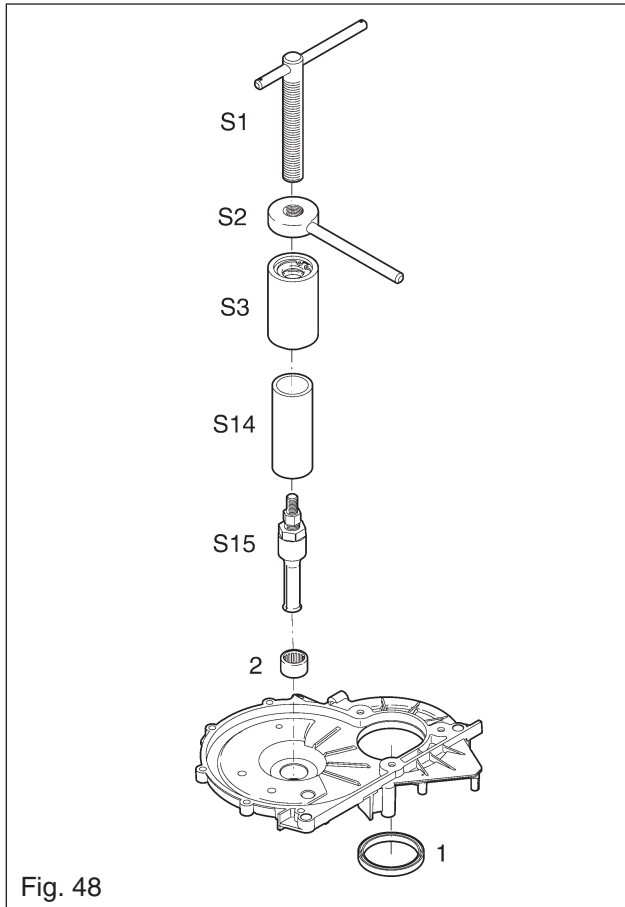

Fig. 48

Use a suitable drift to remove the seal (1), and then discard the seal.

Dismantle the needle bearing (2) with service tools S1, S2, S3, S14 and S15 and discard the bearing.

## Reassembling the transmission cover needle bearing

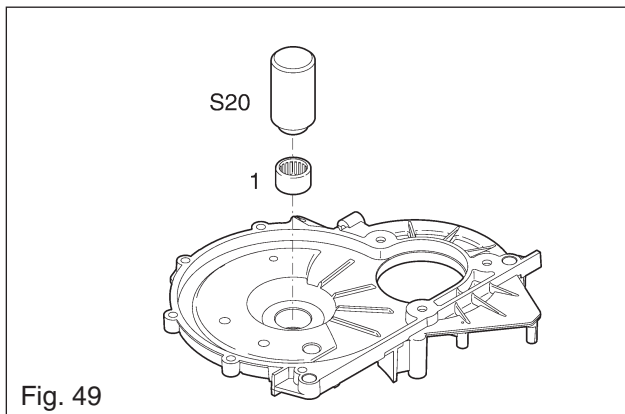

Fig. 49

Fit a new needle bearing (1) using service tool S20.

**Note:** The text on the bearing must face upwards.

## Dismantling of the engine crankshaft bearing and seal on the fan side crankcase

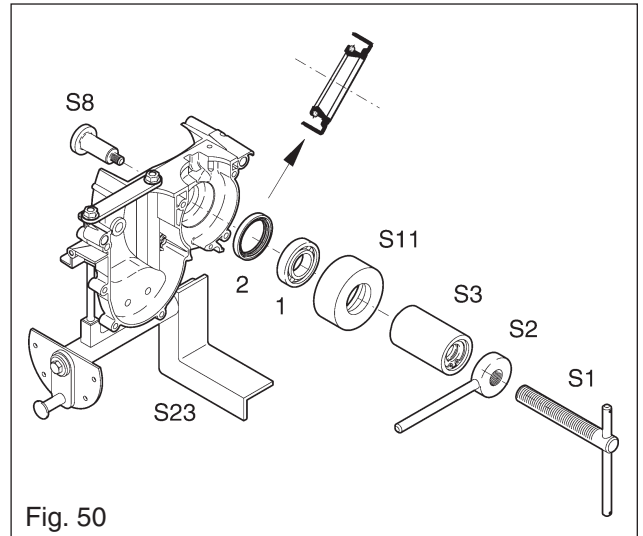

Fig. 50

Fit the crankcase in fixture S23. Use service tools S1, S2, S3, S8 and S11 to dismantle the bearing (1) and the seal (2).

The bearing and the seal are deformed during removal and must be discarded.

## Fitting the engine crankshaft bearing on the fan side crankcase

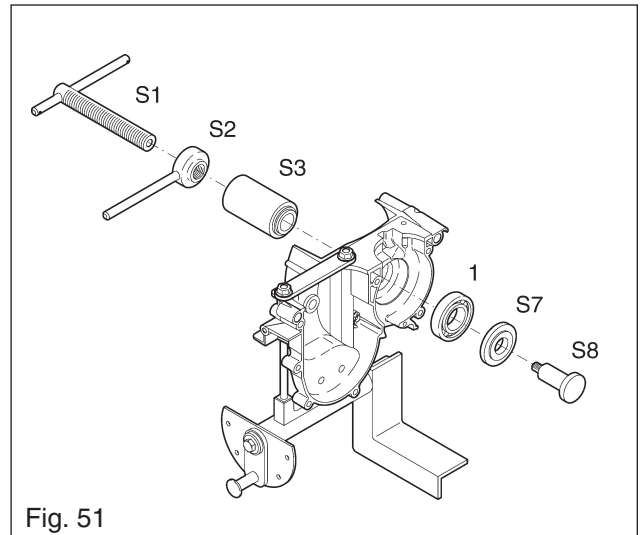

Fig. 51

Fit a new bearing (1) using service tools S1, S2, S3, S7 and S8.

**Note:** Check that the tool S7 faces so that the tractive force is applied to the outer ring of the roller bearing.

## Reassembly of the drive piston connecting rod and engine crankcase

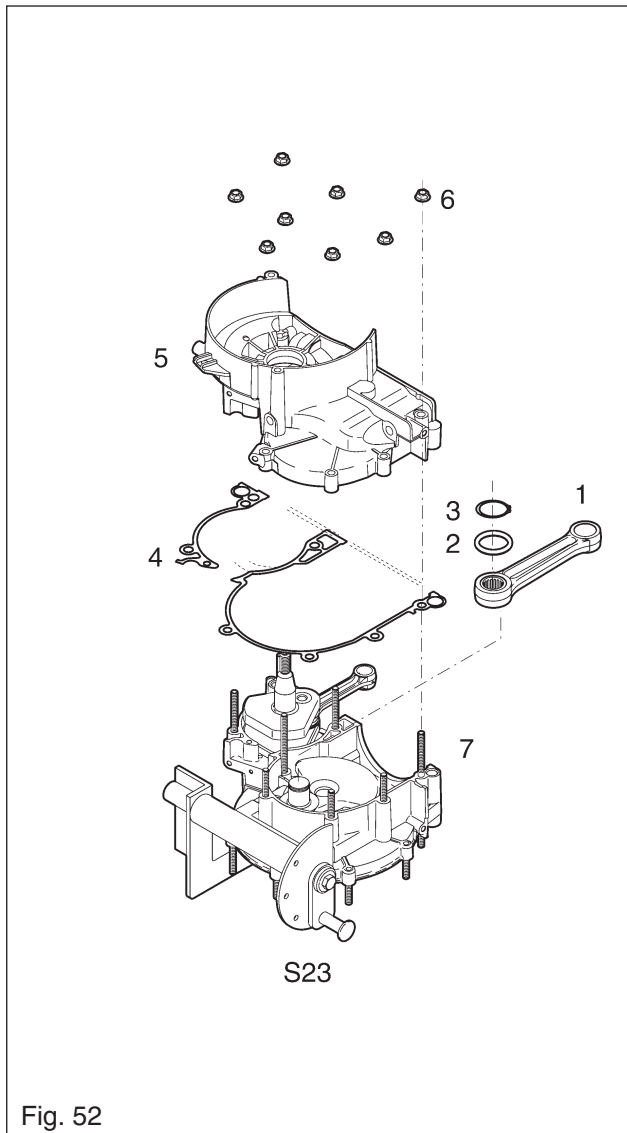

Fig. 52

Fit the transmission side (7) of the crankcase to fixture S23.

Fit the drive piston connecting rod (1) to the hammer crankshaft.

Fit a new washer (2) and locking ring (3).

**Note:** Check carefully that the locking ring is correctly seated in the groove.

Fit a new gasket (4) and install the fan side crankcase (5).

Tighten the eight nuts (6) to the stipulated tightening torque load.

## Assembly of fan side crankcase seal

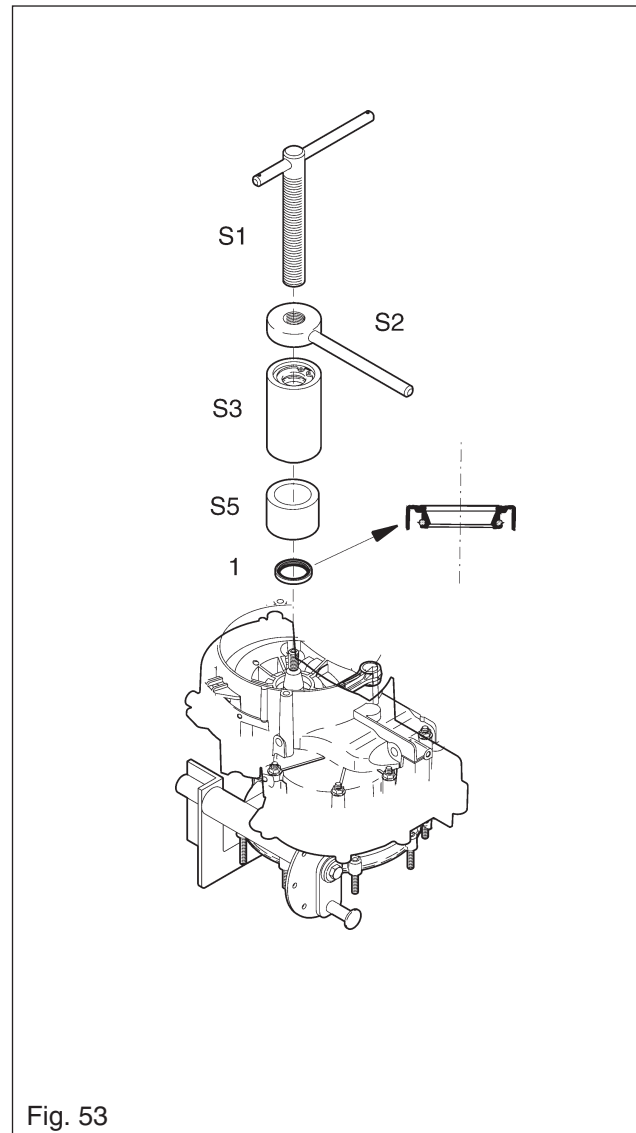

Fig. 53

Fit a new seal (1) using service tools S1, S2, S3 and S5.

Check that the seal is facing in the right direction.

## Reassembly of transmission cover

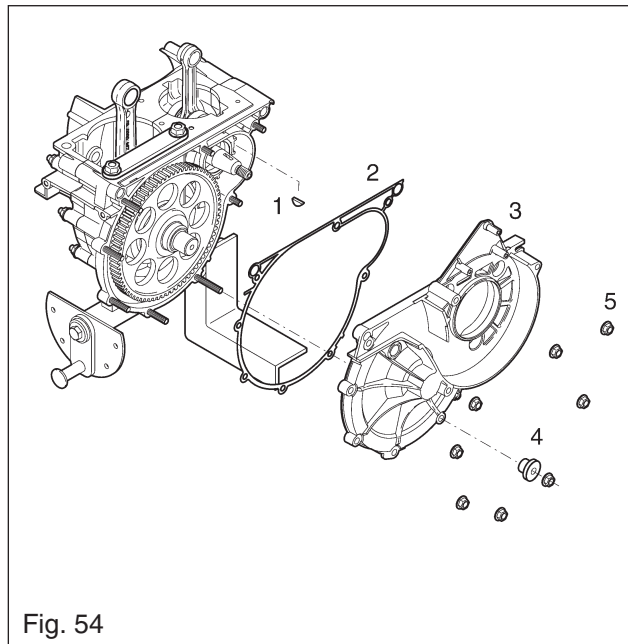

Fig. 54

Fit the Woodruff key (1).

Fit a new gasket (2) and reassemble the transmission cover (3).

Fit the support bush (4) and tighten the eight nuts (5) to the stipulated torque load.

## Reassembly of the transmission cover seal

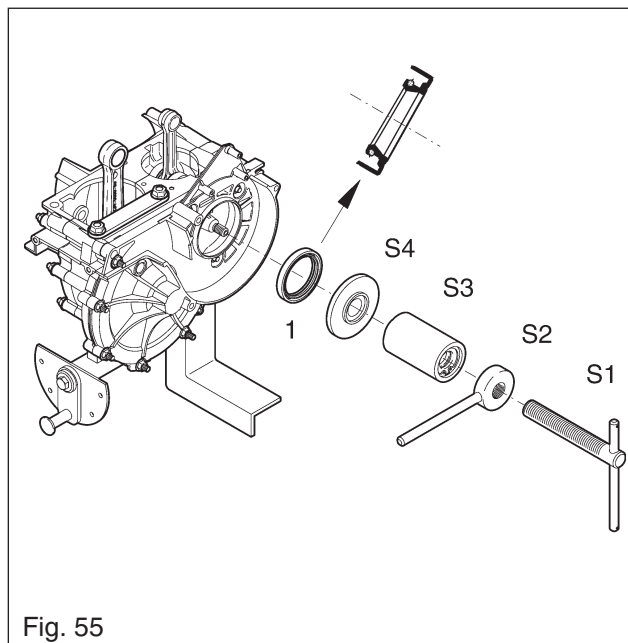

Fig. 55

Fit a new seal (1) using service tools S1, S2, S3 and S4.

Check that the seal is facing in the right direction.

## Reassembly of the engine piston and cylinder

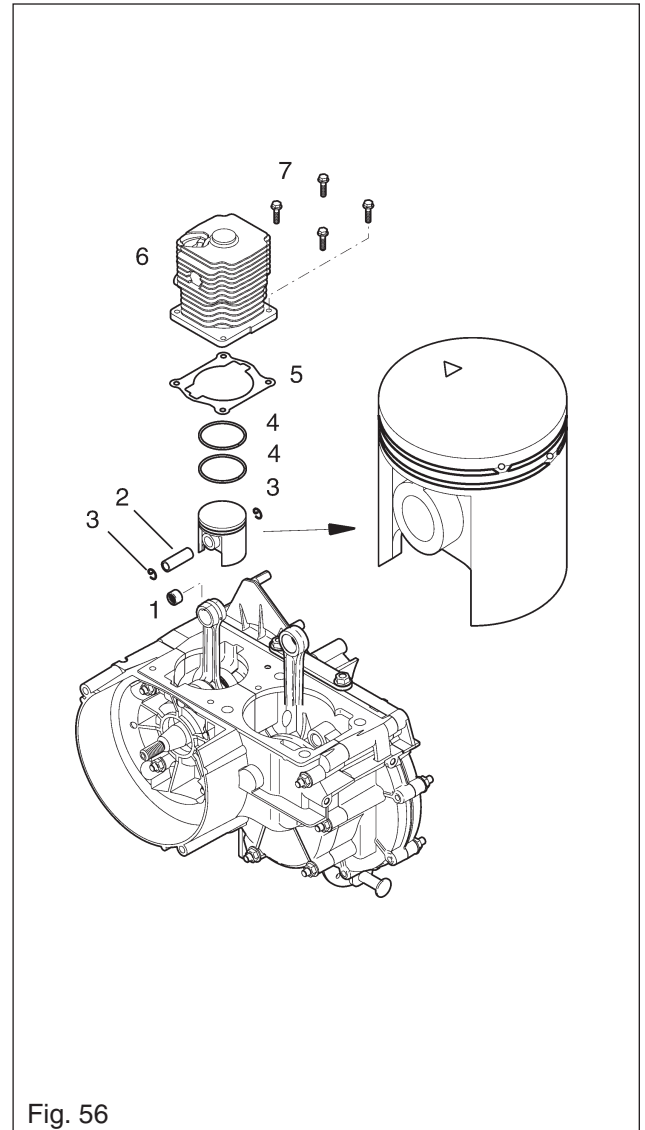

Fig. 56

Fit a new needle bearing (1).

Align the piston over the connecting rod and carefully tap the gudgeon pin into place (2) using a rubber hammer, supporting the connecting rod and the piston at all times.

Fit new locking rings (3).

**Note:** The arrow on the piston crown must point towards the exhaust port of the cylinder.

Fit the piston rings (4) and check that they are correctly seated in the groove. Fit a new gasket (5)

Lubricate the cylinder bore, the piston and the piston rings.

Position the cylinder (6) over the piston at bottom dead centre and slide on the cylinder.

**Note:** Do not rotate the cylinder when it is fitted on the piston, as this may damage the piston rings.

Insert the four screws (7) and tighten them to the stipulated torque load.

## Reassembly of the carrier, flywheel and electronics unit

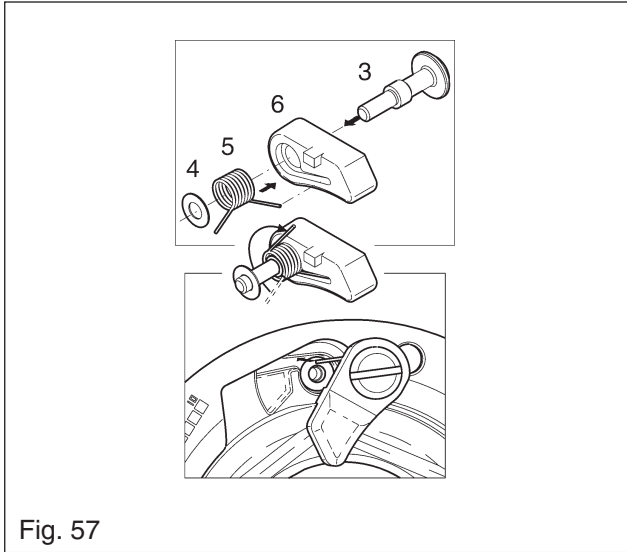

Fig. 57

Insert the screw (3) washer (4) and carrier spring (5) in the carrier (6).

Preload the spring by half a turn and introduce the carrier into place in the flywheel.

Check that the end of the spring is correctly engaged in the groove. Tighten the screw (3) to the stipulated torque load.

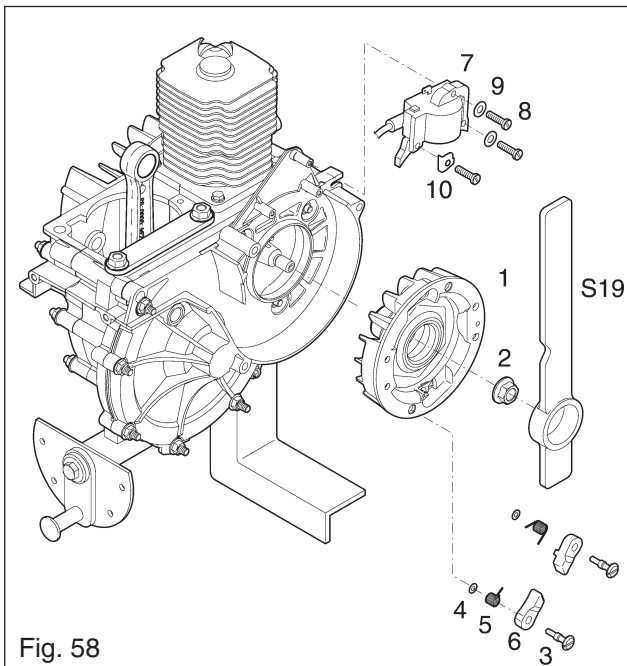
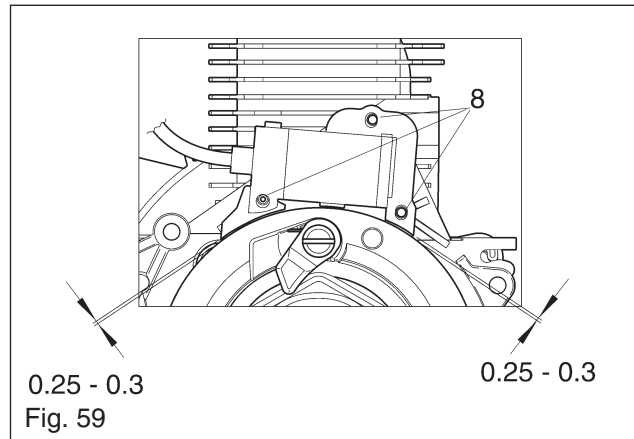

Fig. 58

Fit the flywheel (1) to the crankshaft. Lock the flywheel using service tool S19 and tighten the nut (2) to the stipulated torque load.

Fit the electronics unit (7) to the crankcase using the three screws (8) and the washers (9) and (10).

**Note:** The washer (10) is designed to prevent damage to the plastic case when the screw is tightened.



0.25 - 0.3  
Fig. 59

Tighten the three screws (8) slightly and adjust the gap between the flywheel magneto and the electronics unit to 0.25 – 0.3 mm.

Tighten the screws (8) to the stipulated torque load.

## Reassembly of cooling fan

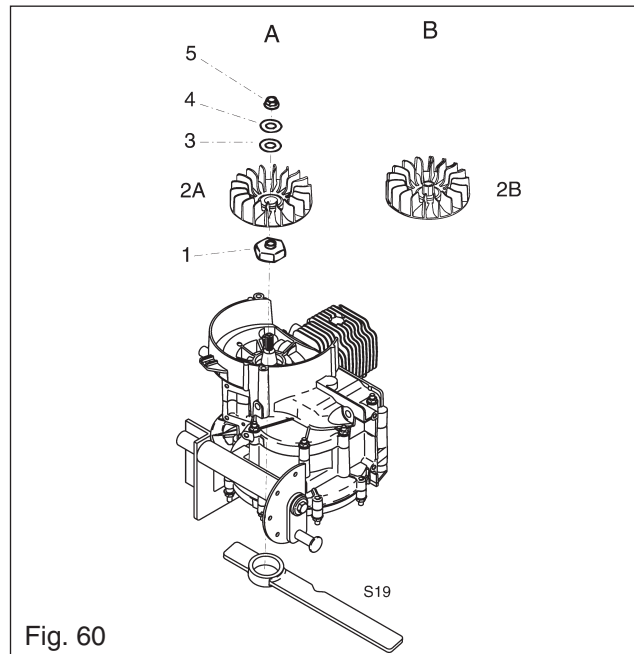

Fig. 60

### Type A

Locate the hub (1) on the crankshaft taper.

Fit the fan (2A), flat washer (3), spring washer (4) and nut (5).

Lock the flywheel using service tool S19 and tighten the nut (5) to the stipulated torque load.

### Type B

**Note.** The crankshaft taper and the internal taper of the fan must be thoroughly degreased before assembly. White spirit or a similar degreasing agent must be used.

Lock the flywheel with service tool S19 and fit the fan to the crankshaft.

**Note.** A torque wrench must be used for tightening, and the fan must be tightened to the stipulated torque load of **8 Nm**

## Reassembly of plastic bushes

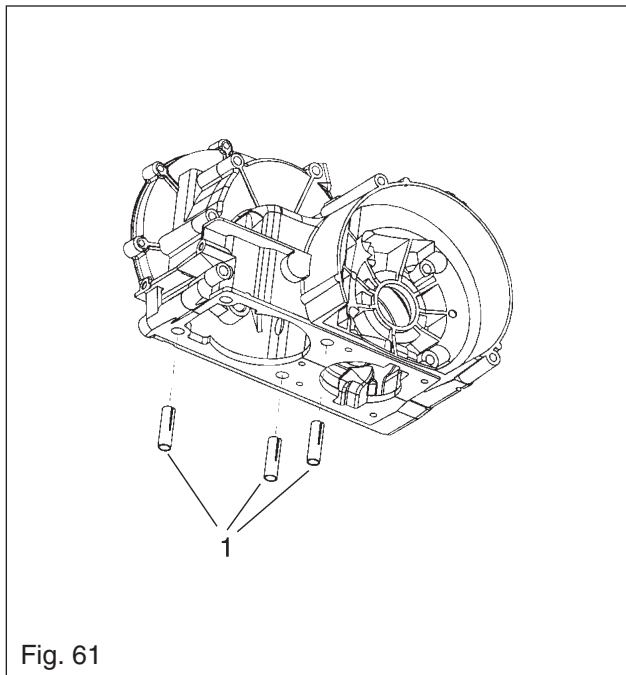

Fig. 61

Fit the bushes (1). The short screw does not require a bush.

**Note:** The bushes must be tapped into the hole with the slot first.

## Reassembly of tool shank

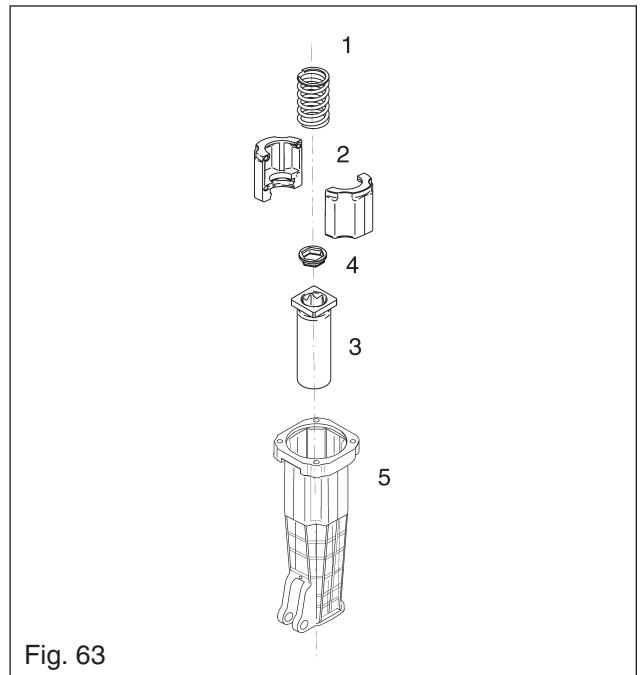

Fig. 63

Fit the seal (4) in the tool shank.

Fit the feed stop (2) on the tool shank (3). Locate the tool shank and the feed stop in the tool holder (5).

**Note:** Check that one side of the hexagon is in alignment with the tool latch.

Locate the spring (1) in the feed stop.

## Reassembly of driver piston

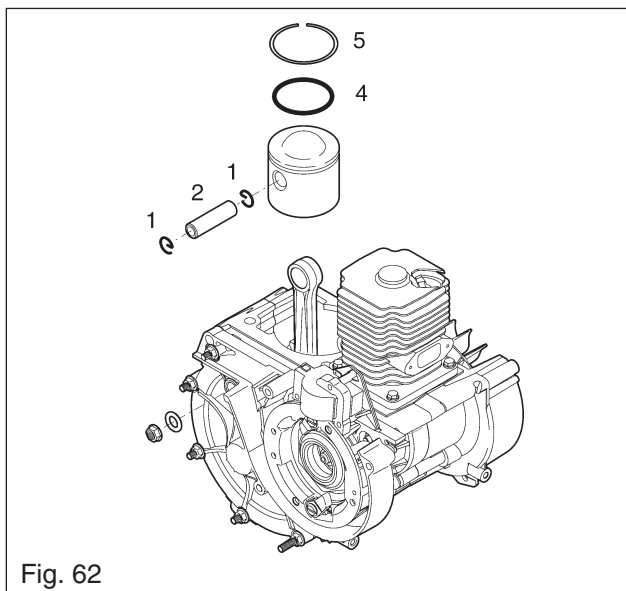

Fig. 62

Fit a new O-ring (4) and piston ring (5).

Locate the drive piston over the connecting rod and insert the gudgeon pin (2), supporting the piston and the connecting rod at all times.

Fit new locking rings (1).

## Fitting the hammer cylinder on the tool holder

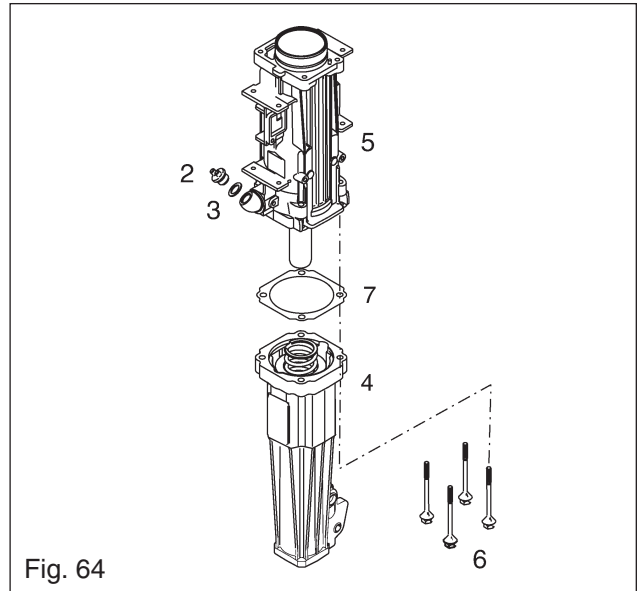

Fig. 64

Place a new gasket (7) on the tool holder (4).

Fit the hammer cylinder (5) to the tool holder and tighten the screws (6) to the stipulated torque load.

Fit a new O-ring (3) to the oil plug (2) and screw in the plug.

## Reassembly of anti-vibration springs

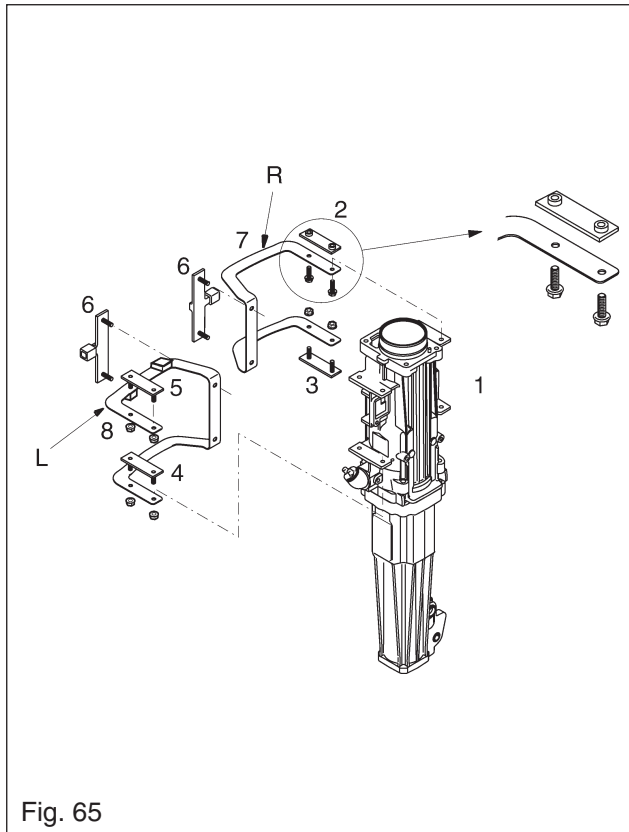

Fig. 65

Fit the leaf spring (7), marked R, on the hammer cylinder (1) with the pressure plates (2) and (3).

**Note:** The upper pressure plate (2) has captive nuts. The other three pressure plates (3), (4) and (5) have captive screws.

Fit the leaf spring (8), marked L, to the hammer cylinder with the two pressure plates (5) and (4).

Fit the end stop (6) to the leaf springs.

## Dismantling and reassembly of right handle

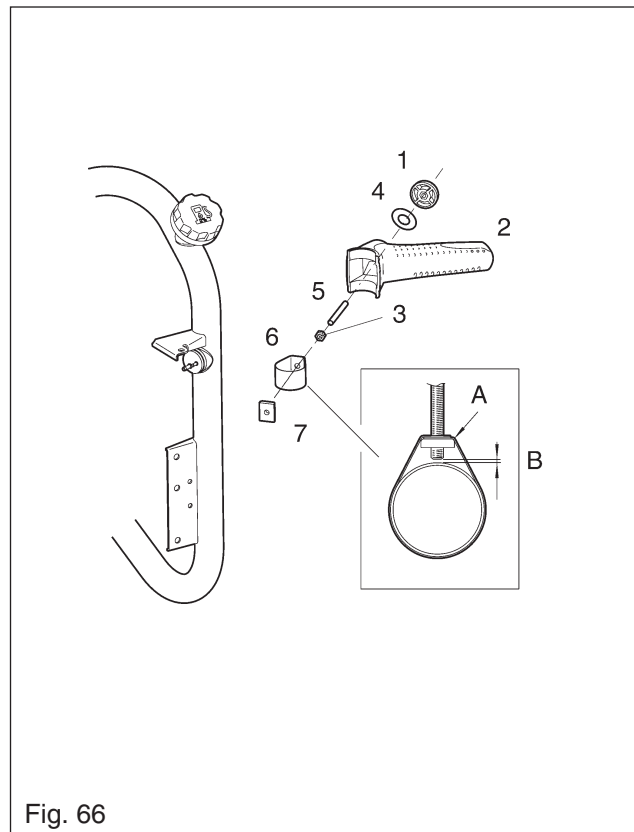

Fig. 66

### Dismantling

Remove the handle locking nut (1) and washer (4) and lift off the handle.

Undo the nut (3) and remove the stud (5).

Dismantle the handle strap (6) and nut (7). If the strap is damaged, it must be replaced.

### Reassembly

Fit the strap (6) to the tank frame. Place the nut (7) in the strap (6).

**Note:** The rounded corners (A) of the nut must seat against the rounded corners of the strap.

Screw the nut (3) onto the stud (5). Screw the stud into the nut (7), but not to the extent that it bottoms against the fuel tank; see (B). Fit the handle (2), washer (4) and locking nut (1).



## Reassembly

Fit the throttle cable(9) and the electrical wires (5) and (6) in the protective sheath (11).

Push the wires down through the hole for the bush (10) and then up through the hole for the stop button.

Connect the wires to the stop button and then fit the stop button in the handle.

**Note:** Check that the stop button is installed in the right direction.

Push the cable down through the hole for the bush (10) and then up through the hole for the throttle lever.

Hook the cable onto the throttle lever.

Fit the throttle lever in the handle and tap in the pin (7). Stretch the cable and the electrical wires and check that the electrical wires do not interfere with the throttle lever and cable.

Fit the nipple (10).

Pass the cable down into the nipple and check that it bottoms.

Pass the protective sheath over the nipple (10).

Fit the handle (2), washer (12) and locking nut (1) to the handle strap. Fix the handle in the correct position on the fuel tank and tighten the handle locking nut (1).

## Reassembly of fuel tank and muffler

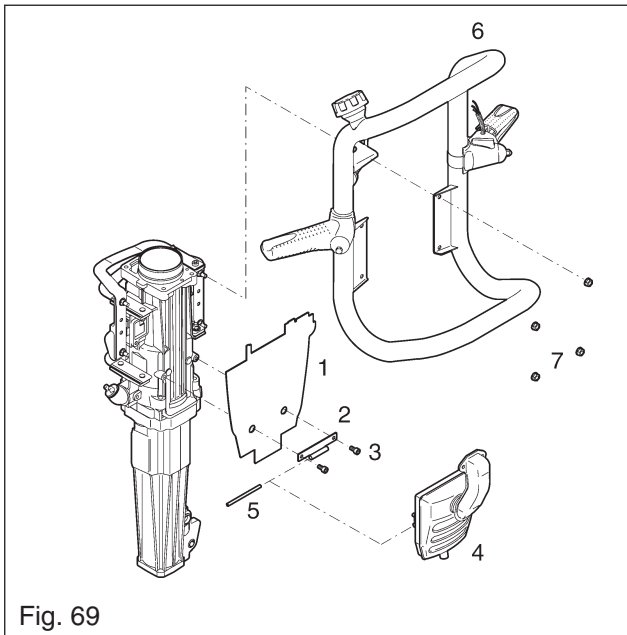

Fig. 69

Locate the heat shield (1) on the hammer cylinder.

**Note:** Check that the heat shield is facing in the correct direction.

Fit the bracket (2) with the screws (3). Fit the muffler (4) to the bracket (2) and tap in the spring pin (5).

Fit the fuel tank (6) to the end stop and tighten the nuts (7).

## Reassembly of engine

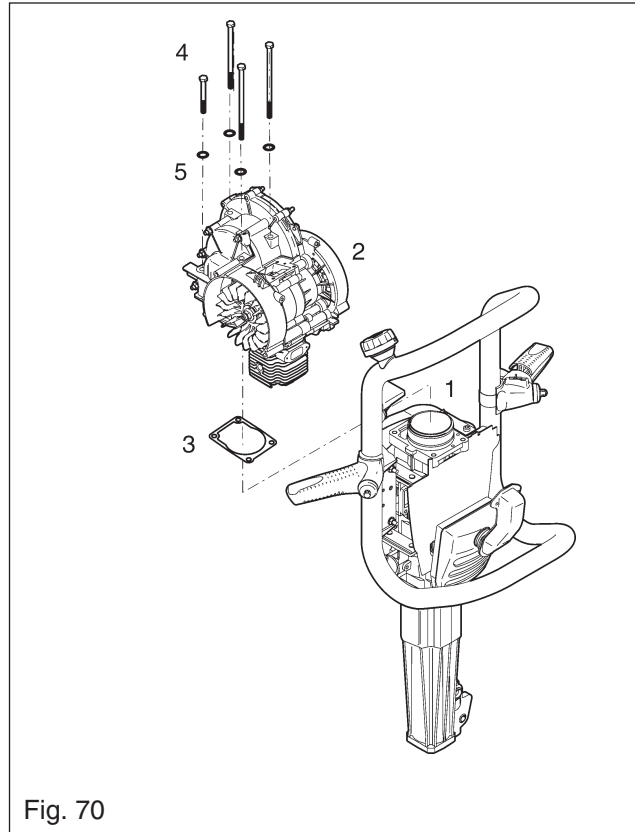

Fig. 70

Lubricate the hammer cylinder bore (1) and the drive piston.

Place a new gasket (3) on the hammer cylinder.

Position the drive piston in the hammer cylinder bore and lower the engine (2) carefully onto the hammer cylinder.

Tighten the engine mounting screws (4) together with the washers (5). The screws must be tightened to the stipulated torque load.

**Note:** The mounting screws (4) must be provided with washers (5) to enable the correct tightening torque load to be contained.

## Fitting the muffler and stabilizer brace

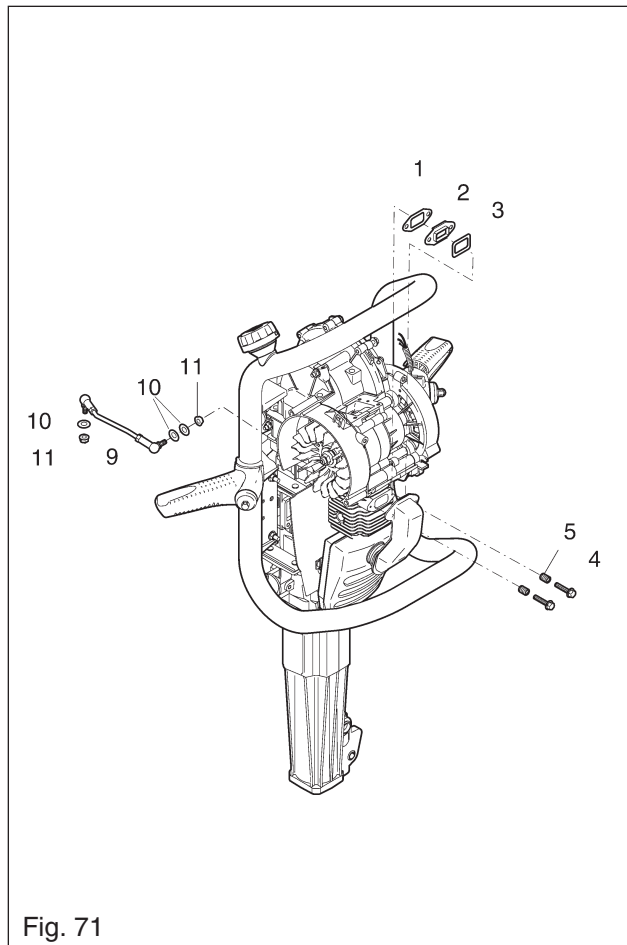

Fig. 71

Fit new gaskets (1) and (3) to the insert (2) and tighten the two screws (4) together with the springs (5).

Fit the stabilizer brace (9) on the fuel tank and the engine. Tighten the nuts (11) and the washers (10).

Push down the handles and check that the stabilizer brace does not make contact with the engine crankcase when the end stop is in its lowest position.

Adjust if necessary.

## Reassembly of filter housing

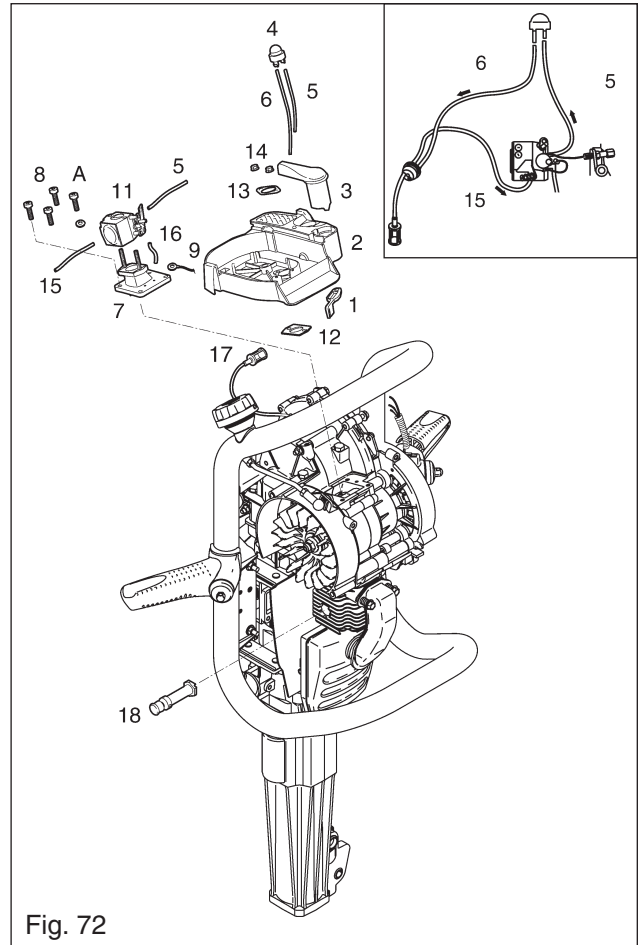

Fig. 72

Fit the diaphragm valve (7) on the crankcase using the four screws (8). Tighten the screws to the stipulated torque load.

**Note:** The stop button earth cable (9) must be located under screw (A).

Fit the choke control (1) in the filter housing (2). Connect the choke lever (3) to the choke control (1). Check that the choke control can move freely.

Fit the venting pump (4) in the filter housing.

Connect the pipes (5) and (6) to the venting pump.

**Note:** The short pipe (5) must be connected to the short nipple, and the long pipe to the long nipple on the venting pump.

Fuel is sucked through the short pipe through the carburettor to the venting pump and is then led back to the tank through the long pipe.

Locate the carburettor (11) on the diaphragm valve (7). Connect the fuel pipe (15), pressure pipe (16) and venting pump pipe (5) to the carburettor.

Place the gasket (12) on the carburettor and fit the filter housing. Fit the flat washer (13) and the nuts (14). Locate the ventilation filter (17) in the holder on the under side of the filter housing. Fit the decompression valve, and tighten it to the stipulated torque load.

## Reassembly of machine covers

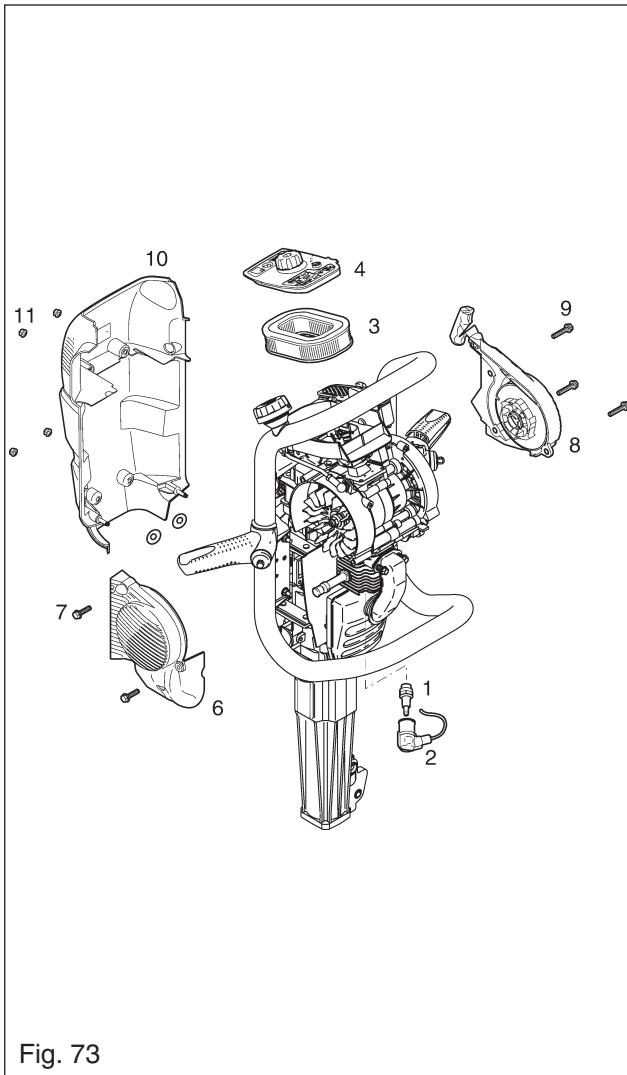

Fig. 73

Check that the spark plug (1) electrode gap is 0.6-0.7 mm. Fit the spark plug, and tighten it to the stipulated torque load.

Locate the air filter (3) in the filter housing and fit the filter cover (4).

Fit the fan cover (6) with the two screws (7) and the starter cover (8) with the three screws (9).

Fit the rear cover (10) with the four nuts (11).

Note: With the front cover removed, easy access is provided to the throttle cable adjuster screw.

## Throttle cable adjustment

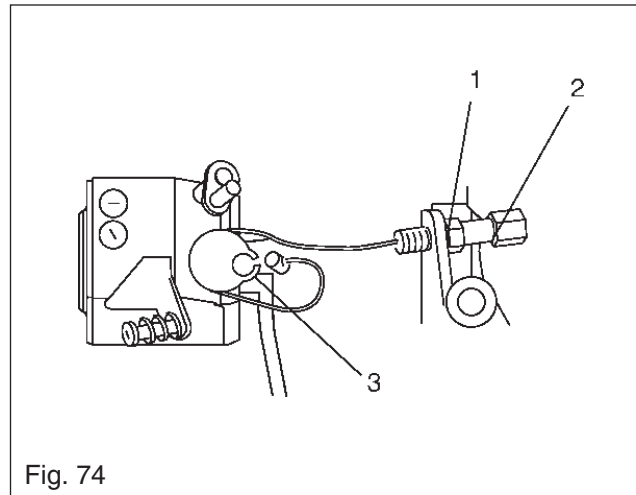

Fig. 74

Slacken the lock nut (1). Use the adjuster screw (2) to set the tension of the cable so that the idling speed is not affected by any movement caused by the anti-vibration springs.

Check the tension by pressing the springs down to their stop position. The throttle valve must not be affected, i.e. the idling speed must not increase.

**Note:** The throttle cable must not be so loose that it risks jumping from the carburettor cable wheel (3).

Fix the setting by tightening the lock nut (1).

## Front cover

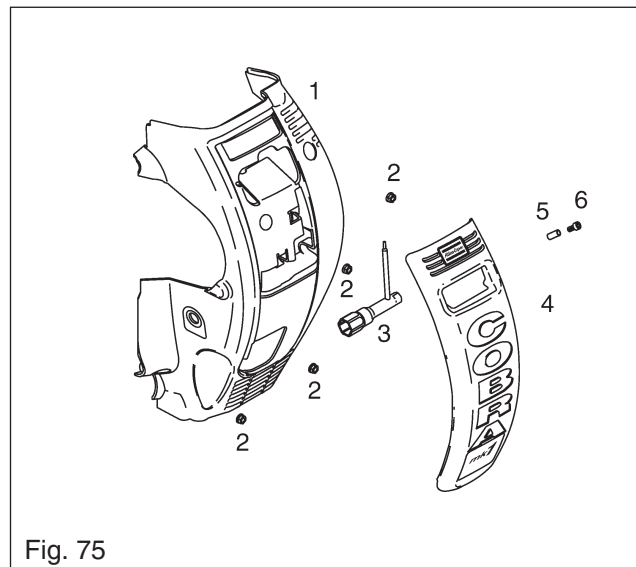

Fig. 75

Fit the front cover (1) and tighten the four nuts (2).

Press in the spark plug spanner (3) and screw the service cover (4) in place with the rubber expander (5) and the screw (6).