

January 1, 1981

**PARTS LIST FOR
HYDRAULIC POWER UNITS
(01-02-03)
AND
PRSSURE-MATIC VALVE
(06-300)**

NOTE:

Always indicate part number or code when ordering parts.

Always indicate the serial number of the cylinder or pump when corresponding or ordering parts.

See current price list for prices and shipping weights.

PARTS FOR HYDRAULIC POWER UNITS

ITEM	PART NO.	DESCRIPTION	NO. REQ.	ITEM	PART NO.	DESCRIPTION	NO. REQ.
1	501	Dip Stick	1	32	703	Head Hex Cap Screw	4
2	504	Nut	3	33	744	Tee	1
3	505	Lock Washer	3	34	706A	Socket Head Screw	3
4	506	Stud	3	35	708B	Socket Head Screw	2
5	507	Flange Adapter A/M or E/M	1	36	500	Air Motor, 3Hp, Complete	1
7	512	Sleeve (Rim)	2	37	619	Muffler Assembly	1
8	513	Nut	2	38	06-300	Pressure-Matic Valve Assembly – see next page	1
9	514	Oil Line	1	39	683	Cord – 8' for E/M	1
10	515	Relief Valve – 10,000psi	1	40	552	Plug	1
11	516	Check Block	1	41	601	Phillips Head Cap Screw*	3
12	516A	O-Ring	1	42	602	Dead End Bearing Cover*	1
13	517B	Filter Assembly	1	43	617	End Cap Gasket*	1
14	518	Filter Extension	1	44	608	Dead End Bearing*	1
15	519	Adapter	1	45	603	Hex Head Cap Screw*	1
16	520	O-Ring	1	46	---	Dead End Casting – NOT AVAILABLE*	
17	521	Basic Pump	1	47	613	Body Gasket*	1
18	522	Reservoir – 5 US Gal.	1	48	000	Body Casting – NOT AVAILABLE*	1
19	523	Gasket – 4 piece	1	49	616	Rotor Assembly*	1
20	524	Cover Plate	1	50	604	Vane *	4
21	545	Screw	10	51	000	Drive End Casting – NOT AVAILABLE*	
22	546	Gasket	1	52	607	Drive End Bearing *	1
23	547	Adapter	1	53	611	Seal (shaft) *	1
24	548	Bearing	1	54	615	O-Ring*	1
25	550EA	Shaft Adapter, 5/8", Air & Electric	1	55	623	Drive end Bearing Cover*	1
25	550G	Shaft Adapter, 7/8" Gas Engine	1	56	624	Socket Head Cap Screw*	6
27	660	Gas Engine, 3.5 Hp, B/S	1	57	521	Screen*	2
28	662	Woodruff Key	1	58	620	Felt Disk*	1
29	680	Electric Motor, 1.5Hp, 110/220V	1	59	422	Air Coupler, 3/4"	1
30	551	Drive Coupler	1	60	419	Air Valve, 3/4" with Restrictor	1
31	303	Lock Washer	2	61	558	O-Ring	1
Casting items #46, 48 and 51 are NOT AVAILABLE. Must purchase a whole new air motor. *An air motor repair kit can be ordered with part #07-9.				62	559	Street Elbow	2
				63	560	Bulkhead Connection	2
				64	561	Drain Line	1
				65	739	Key	1
				66	---	Sleeve & Nut – included with part #560	

**PARTS FOR PRESSURE-MATIC VALVE
06-300**

The 06-300 pressure-matic valve is factory set to operate the hydraulic cylinder at 7100psi. Do no adjust to any higher setting than 7100psi.

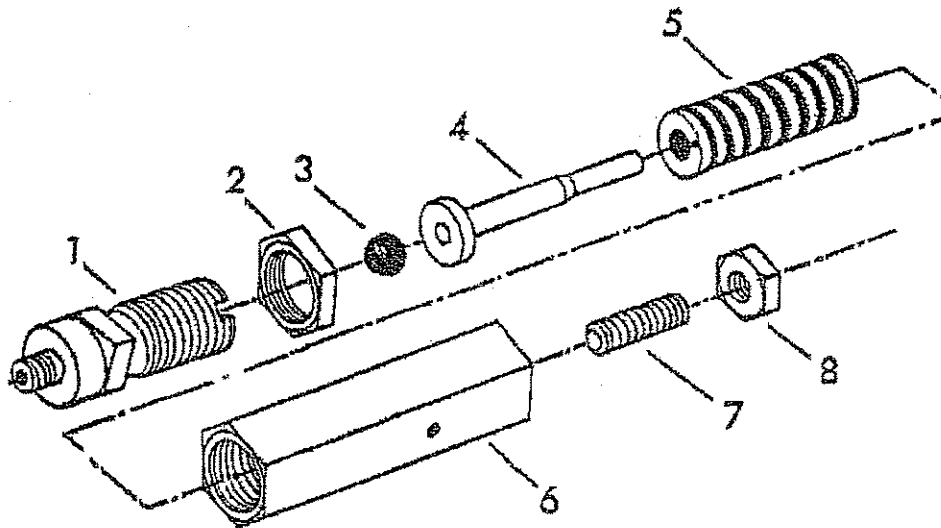

ITEM NO	PART NO	DESCRIPTION	NO. REQ.
1	0660	Valve Seat	1
2	0667	Housing Lock Nut	1
3	0661	Ball	1
4	0666	Valve Stem	1
5	0662	Spring	1
6	0665	Valve Housing	1
7	0663	Set Screw	1
8	0664	Lock Nut	1

PRESSURE ADJUSTMENT PROCEDURE

#06-300 PRESSURE-MATIC VALVE

1. Remove reservoir cover plate screws and tip cover plate so you have access to the valve
2. Loosen Housing Lock Nut (#2). Turn Valve Housing (#6) clockwise to increase pressure and counterclockwise to decrease pressure.
3. Loosen Lock Nut (#8). Turn Set Screw (#7) until it touches the end of Valve Stem (#4). Back off Set Screw (#7) 1/8 turn.
4. Tighten Lock Nuts (#2 and #8)
5. Recheck pressure and install cover plate.