

**INSTRUCTIONS**  
**for**  
**CARE AND OPERATION OF**  
**JH40**  
**JACKHAMER DRILL**

**INGERSOLL-RAND**

CROWDER SUPPLY CO, INC. - 8495 ROSLYN ST. - COMMERCE CITY, CO 80022 - TOLL FREE 888-883-5144 - www.crowdersupply.com

Refer All Communications To The  
Nearest Address Listed On The Back Cover

**INGERSOLL-RAND®**  
**DRILLING EQUIPMENT**

# CONSTRUCTION AND DRILLING EQUIPMENT SOLD BY DISTRIBUTORS

## Warranty

Ingersoll-Rand, through its distributor, warrants that each item of equipment manufactured by it and delivered hereunder to the initial user to be free of defects in material and workmanship for a period of three (3) months from initial operation or six (6) months from the date of shipment to the initial user, whichever first occurs.

With respect to the following types of equipment, the warranty may be augmented as hereinafter specifically stipulated and the warranty period enumerated below will apply in lieu of the foregoing warranty period.

- A. Drill Mountings—The earlier of six (6) months from initial operation or nine (9) months from date of shipment to the initial user.
- B. Portable Compressors—The earlier of twelve (12) months from shipment to, or the accumulation of 2,000 hours of service by the initial user.
- C. All Compressor Air Ends—The earlier of twenty-four (24) months from shipment to, or the accumulation of 4,000 hours of service by, the initial user. The warranty against such defects will include replacement of the complete air end provided the original air end is returned assembled and unopened.
- D. Rotary Drills—The earlier of six (6) months from shipment to, or the accumulation of 1,000 hours of service by, the initial user.
- E. Self-Propelled Compactor—The earlier of twelve (12) months from shipment to, or the accumulation of 1,000 hours of service by, the initial user.
- F. Downhole Drills—In lieu of the repair or replacement of defective parts described below Ingersoll-Rand may elect to issue full or partial credit toward the purchase of a new part. The extent of credit

issued will be determined by prorating against the normal service life of the part in question.

Ingersoll-Rand will provide a new part or repaired part, at its election, in place of any part which is found upon its inspection to be defective in material and workmanship during the period prescribed above. Such part will be repaired or replaced without charge to the initial user during normal working hours at the place of business of an Ingersoll-Rand distributor authorized to sell the type of equipment involved or other establishment authorized by Ingersoll-Rand. User must present proof of purchase and date at the time of exercising this warranty.

This warranty does not apply to failures occurring as a result of abuse, misuse, negligent repairs, corrosion, erosion and normal wear and tear, alterations or modifications made to the product without express written consent of Ingersoll-Rand, or failure to follow the recommended operating practices and maintenance procedures as provided in the product's operating and maintenance publications.

Accessories or equipment furnished by Ingersoll-Rand, but manufactured by others, including, but not limited to, engines, tires, batteries, engine electrical equipment, hydraulic transmissions, carriers, shall carry whatever warranty the manufacturers have conveyed to Ingersoll-Rand and which can be passed on to the initial user.

THIS WARRANTY IS IN LIEU OF ALL OTHER WARRANTIES (EXCEPT OF TITLE), EXPRESSED OR IMPLIED, AND THERE ARE NO WARRANTIES OF MERCHANTABILITY OR OF FITNESS FOR A PARTICULAR PURPOSE.

## Limitation of Liability

The remedies of the user set forth under the provisions of warranty outlined above are exclusive and the total liability of Ingersoll-Rand or its distributor with respect to this sale or the equipment and service furnished hereunder, in connection with the performance or breach thereof, or from the sale, delivery, installation, repair or technical direction covered by or furnished under this sale, whether based on contract, warranty, negligence, indemnity, strict liability or otherwise shall not exceed the purchase price of the unit of equipment upon which such liability is based.

Ingersoll-Rand, its supplier(s) and its distributors shall in no event be liable to the user, any successors in interest or any beneficiary of assignee relating to this sale for any consequential, incidental, indirect, special

or punitive damages arising out of this sale or any breach thereof or any defects in or failure of or malfunction of the equipment under this sale whether based upon lost goodwill, lost profits or revenue, interest, work stoppage, impairment of other goods, loss by reason of shutdown or non-operation, increased expenses of operation of the equipment, loss of use of power system, cost of purchase of replacement power or claims of users or customers of the user for service interruption whether or not such loss or damage is based on contract, warranty, negligence, indemnity, strict liability or otherwise.

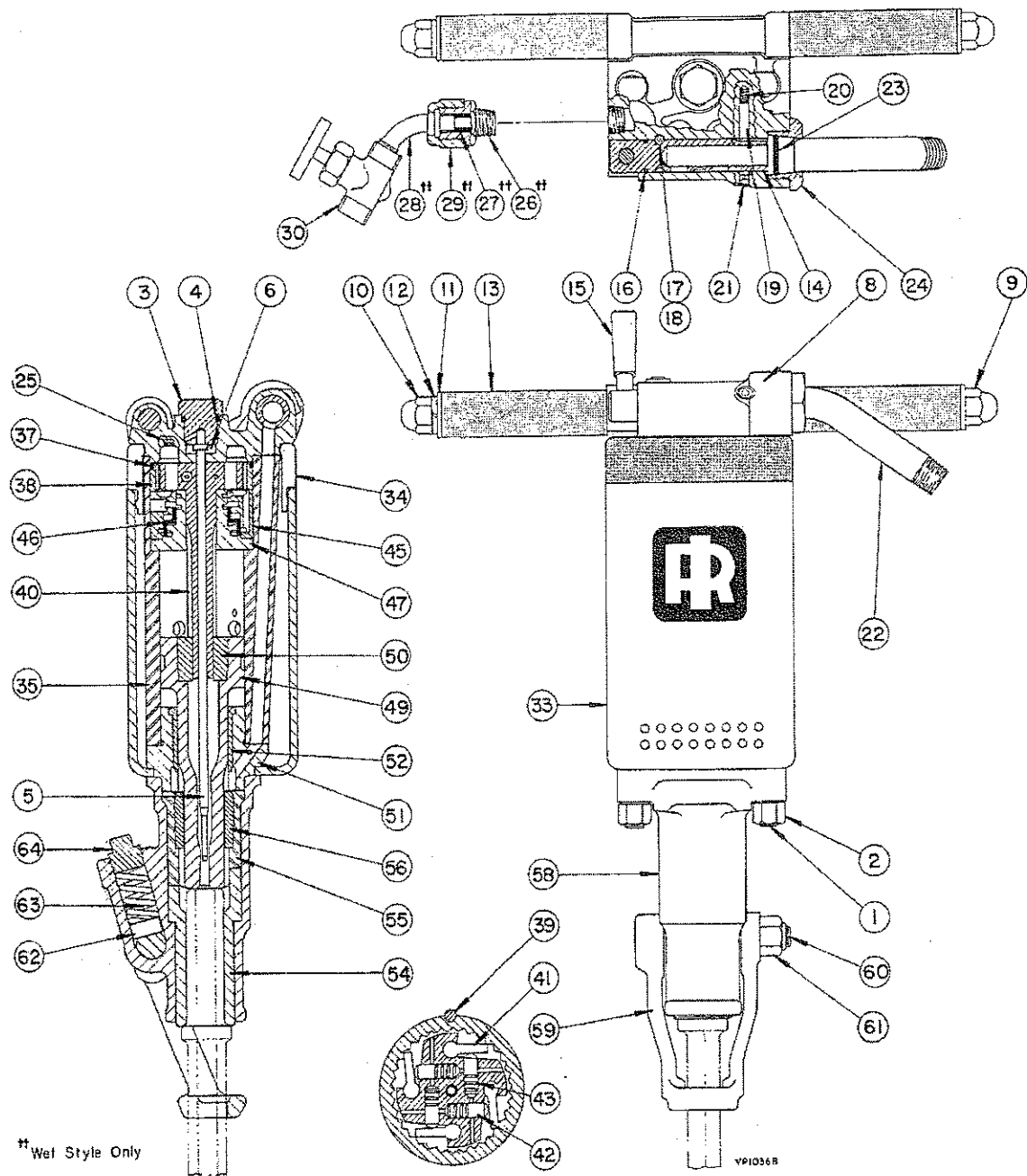

†† Wet Style Only

- |                    |                        |                       |                  |
|--------------------|------------------------|-----------------------|------------------|
| 1. Assembly Rod    | 16. *O* Ring           | 30. Valve (Wet Style) | 49. Piston       |
| 2. Nut             | 17. Pin                | 33. Muffler           | 50. Rifle Nut    |
| 3. Tube Retainer   | 18. Plug               | 34. Cap               | 51. Bearing      |
| 4. *O* Ring        | 19. Plunger            | 35. Cylinder          | 52. Sleeve       |
| 5. Tube            | 20. Spring             | 37. Seal              | 54. Chuck        |
| 6. Rubber          | 21. Plug               | 38. Rotation Ratchet  | 55. Driver       |
| 8. Handle          | 22. Hose Connection    | 39. Dowel Pin         | 56. Nut          |
| 9. Handle Bolt     | 23. *O* Ring           | 40. Rifle Bar         | 58. Fronthead    |
| 10. Nut            | 24. Cap                | 41. Pawl              | 59. Steel Holder |
| 11. Washer         | 25. Plug (Wet Style)   | 42. Plunger           | 60. Bolt         |
| 12. Lockwasher     | 26. Spud (Wet Style)   | 43. Spring            | 61. Nut          |
| 13. Handle Grip    | 27. Rubber (Wet Style) | 45. Valve Chest       | 62. Plunger      |
| 14. Throttle Valve | 28. Stem (Wet Style)   | 46. Valve             | 63. Spring       |
| 15. Lever          | 29. Nut (Wet Style)    | 47. Valve Guide       | 64. Plug         |

Figure 1-1. JH40 Jackhammer (Yoke Type Steel Holder Construction)

## TABLE OF CONTENTS

Section	Paragraph	Title	Page
<b>I</b>			
<b>DESCRIPTION</b>			
	1-1	GENERAL DESCRIPTION.....	1
	1-1.1	Hole Cleaning Styles.....	1
	1-1.2	Steel Holder Constructions.....	1
	1-2	SPECIFICATIONS.....	1
	1-3	DESIGN FEATURES.....	1
<b>II</b>			
<b>OPERATION</b>			
	2-1	AIR REQUIREMENTS.....	3
	2-1.1	Air Pressure and Volume.....	3
	2-1.2	Air Hoses and Fittings.....	3
	2-2	WATER REQUIREMENTS.....	3
	2-3	SAFETY PRECAUTIONS.....	3
	2-4	BEFORE OPERATION.....	4
	2-5	OPERATING CONTROLS.....	4
	2-6	OPERATION.....	4
	2-6.1	Collaring the Hole.....	5
	2-6.2	Drilling the Hole.....	5
	2-6.3	Cleaning the Hole.....	5
	2-6.4	Stuck Steel.....	5
	2-7	DRILLING TIPS.....	5
	2-7.1	Suggestions for Drillers.....	5
	2-7.2	Drill Steel Care.....	6
	2-7.3	Bit Care.....	6
<b>III</b>			
<b>MAINTENANCE</b>			
	3-1	LUBRICATION.....	7
	3-1.1	Lubricating Oil Specifications.....	7
	3-2	TROUBLE SHOOTING.....	7
	3-3	DISASSEMBLY, INSPECTION AND REASSEMBLY.....	9
	3-3.1	Preliminary Disassembly Instructions.....	9
	3-3.2	Disassembly.....	9
	3-3.3	Inspection & Repair of Parts.....	12
	3-3.4	Preliminary Reassembly Instructions.....	13
	3-3.5	Reassembly.....	13
	3-4	PERFORMANCE TESTING.....	14

The **DANGERS**, **CAUTIONS**, and **NOTES** used throughout the text of this instruction book are defined as follows:

**DANGER**— A specific procedure or practice that must be strictly followed, or a specific condition that must be met, to prevent possible bodily injury.

**CAUTION**—A specific procedure or practice that must be strictly followed, or a specific condition that must be met, to prevent damage to the equipment.

**NOTE**— Important supplemental information.

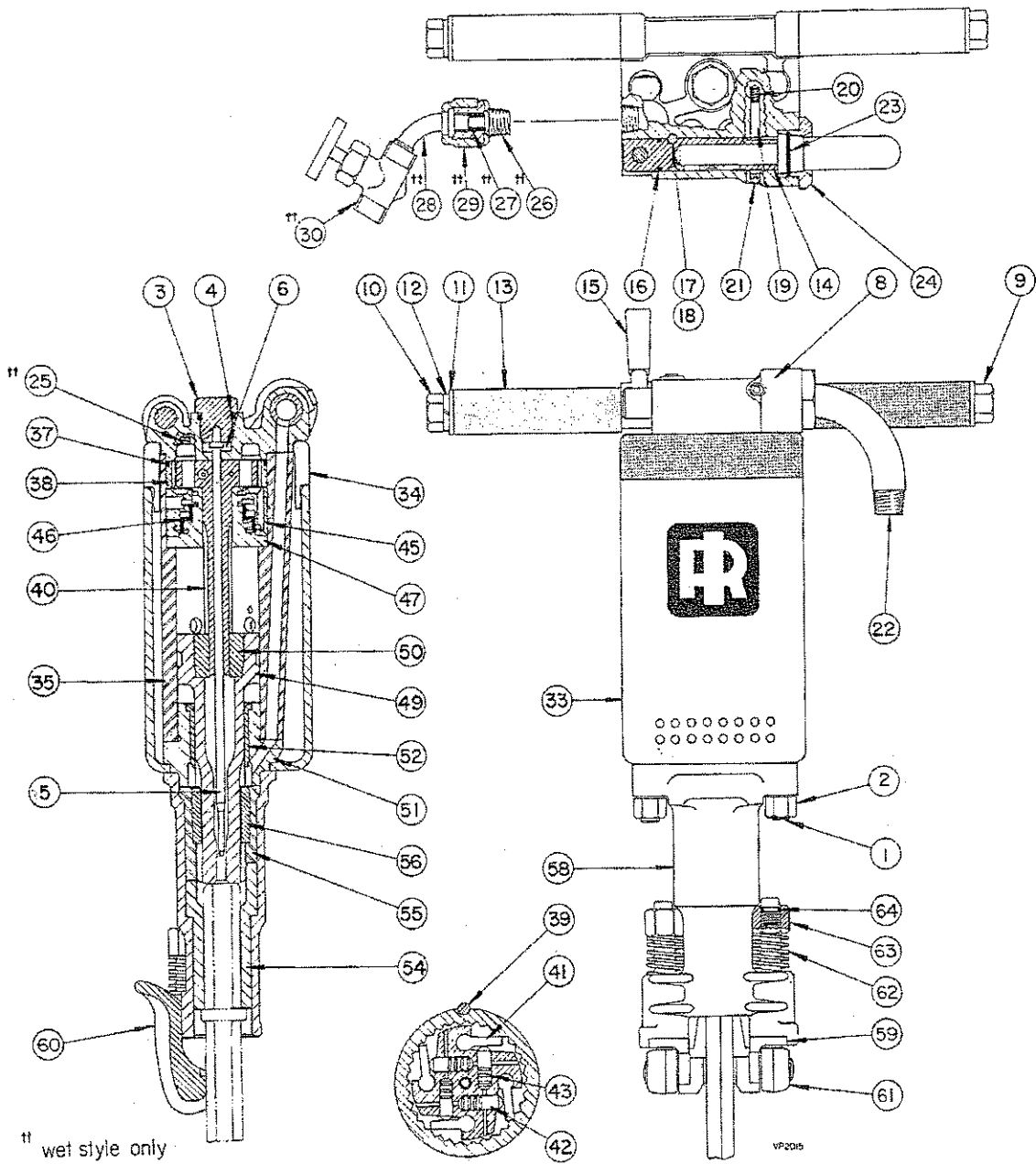

\*\* wet style only

- |                    |                        |                       |                    |
|--------------------|------------------------|-----------------------|--------------------|
| 1. Assembly Rod    | 16. *O* Ring           | 30. Valve (Wet Style) | 49. Piston         |
| 2. Nut             | 17. Pin                | 33. Muffler           | 50. Rifle Nut      |
| 3. Tube Retainer   | 18. Plug               | 34. Cap               | 51. Bearing        |
| 4. *O* Ring        | 19. Plunger            | 35. Cylinder          | 52. Sleeve         |
| 5. Tube            | 20. Spring             | 37. Seal              | 54. Chuck          |
| 6. Rubber          | 21. Plug               | 38. Rotation Ratchet  | 55. Driver         |
| 8. Handle          | 22. Hose Connection    | 39. Dowel Pin         | 56. Nut            |
| 9. Handle Bolt     | 23. *O* Ring           | 40. Rifle Bar         | 58. Fronthead      |
| 10. Nut            | 24. Cap                | 41. Pawl              | 59. Bushing        |
| 11. Washer         | 25. Plug (Wet Style)   | 42. Plunger           | 60. Steel Holder   |
| 12. Lockwasher     | 26. Spud (Wet Style)   | 43. Spring            | 61. Bolt           |
| 13. Handle Grip    | 27. Rubber (Wet Style) | 45. Valve Chest       | 62. Spring         |
| 14. Throttle Valve | 28. Stem (Wet Style)   | 46. Valve             | 63. Nut            |
| 15. Lever          | 29. Nut (Wet Style)    | 47. Valve Guide       | 64. Retaining Ring |

Figure 1-2. JH 40 Jackhammer (Beavertail Type Steel Holder Construction)

## SECTION I DESCRIPTION

### 1-1 GENERAL DESCRIPTION

The JH40 Jackhammer is a hand-held, medium-weight, muffled, pneumatic rock drill with automatic rifle bar rotation, and exceptional hole cleaning ability. It is designed for blower or wet drilling; incorporates control of "hole blowing" in the throttle lever for one-lever, simplified control; and is equipped with a closed-center, T-Handle for general ground level work.

The JH40 is capable of drilling 2 in. (50.8 mm) diameter holes, up to 18 ft (5.5 m) deep in medium to hard rock. It is particularly suitable for construction work, heavy industrial maintenance work, and for general utility service in mines and quarries.

#### 1-1.1 HOLE CLEANING STYLES

a. **Blower Style**—The blower style machine is considered the standard drilling style for the JH40 Jackhammer. This style is designed for dry drilling where maximum hole cleaning ability is required.

b. **Wet Style**—The wet style machine is designed for dustless, wet drilling and is considered optional. This style is for work where minimum air consumption is of the utmost importance. A water connection (stem and nut) and water valve are furnished with each complete wet style JH40 Jackhammer.

#### 1-1.2 STEEL HOLDER CONSTRUCTIONS

a. **Yoke Type Steel Holder (Figure 1-1)**—The standard JH40 Jackhammer is equipped with a yoke type steel holder which is easily operated by hand, but can be released by foot.

b. **Beavertail Type Steel Holder (Figure 1-2)**—When specially ordered, a beavertail type steel holder will be furnished in place of the yoke type steel holder. This steel holder is designed for foot operation.

### 1-2 SPECIFICATIONS

**Table 1-1 General Specifications**

	Metric	(U.S.)
Net Weight/std yoke type steel holder.....	26.3 kg	(58 lb)
Net Weight/opt beavertail type steel holder.....	27.7 kg	(61 lb)
Overall Length (less drill steel and with throttle lever horizontal)...	571.5 mm	(22 1/2 in.)
Cylinder Bore.....	63.5 mm	(2 1/2 in.)
Working Stroke.....	66.7 mm	(2 5/8 in.)
Standard Rotation.....	4 - Pawl Upstroke 1 turn in 762 mm (30 in.)	
Standard Shank Size/std yoke type steel holder.....	25.4 mm hex. X 108 mm lg (1 in. hex. X 4 1/4 in. lg)	
Optional Shank Sizes/opt yoke type steel holder.....	22 mm hex. X 108 mm lg (7/8 in. hex. X 4 1/4 in. lg) 22 mm hex. X 83 mm lg (7/8 in. hex. X 3 1/4 in. lg)	
Optional Shank Sizes/opt beavertail type steel holder.....	25.4 mm hex. X 108 mm lg (1 in. hex. X 4 1/4 in. lg) 22 mm hex. X 108 mm lg (7/8 in. hex. X 4 1/4 in. lg) 22 mm hex. X 83 mm lg (7/8 in. hex. X 3 1/4 in. lg)	
Size of Air Inlet.....	3/4 in. NPT (male)	
Size of Air Hose Recommended....	19 mm (3/4 in.)	

**Table 1-2. Shipping Information**

	Metric	(U.S.)
Net Weight.....	26.3 kg	(58 lb)
Shipping Weight (Export or Domestic).....	27.2 kg	(60 lb)
Cu. Contents (Boxed for Shipment).....	0.04 m <sup>3</sup>	(1-5 ft <sup>3</sup> )

**Table 1-3. Air Consumption**

AIR PRESSURE		AIR CONSUMPTION	
		Blower Style	Wet Style
kPa	(lb/in. <sup>2</sup> )	m <sup>3</sup> /min. (ft <sup>3</sup> /min.)	m <sup>3</sup> /min. (ft <sup>3</sup> /min.)
345	(50)	1.87 to 1.98 (66 to 70)	1.58 to 1.70 (56 to 60)
483	(70)	2.63 to 2.80 (93 to 99)	2.35 to 2.52 (83 to 89)
621	(90)	3.25 to 3.54 (115 to 125)	2.83 to 3.11 (100 to 110)

### 1-3 DESIGN FEATURES

1. The forged steel, closed-type, T-Handle is equipped with rubber grips to provide a comfortable cushion for the operator's hands.

2. A convenient one-piece tube retainer allows for easy removal of the blower or water tube.

3. The main throttle valve (in the handle) also controls the hole blowing. When the throttle valve lever is thrown to the extreme backward position, air is delivered to the chuck through the blower port in the handle, connecting port in the cylinder, and port through the piston stem bearing.

The blower port also carries a constant stream of oil laden air to the front end parts when the throttle valve is in the "FULL ON" drilling position (throttle lever moved to extreme forward position).

4. Large bearing surfaces on the cylinder and front-head extend joint life, and maintain positive front end alignment.

5. The valve chest is a double kicker port type with cylindrical valve; however, the valve chest, valve guide, and valve are designed to provide better "sealing" of the control ports, thereby increasing the efficiency and drilling speed of the machine. The "end seat" and "diametrical" seal design of both ends of the valve make it less sensitive which insures proper performance after much wear.

The valve chest assembly consists of only three pieces which forms a compact unit located in the rear counter-bore of the cylinder. A round key prevents the chest from rotating and simplifies assembly.

6. A four-pawl rifle bar and ratchet are located immediately behind the valve chest. A seal on the rotation ratchet prevents air leakage into the valve chest counter-bore, and when the handle is assembled, it seats on the seal and holds the valve chest and rotation assemblies firmly together in the cylinder.

7. A one-piece, high-density, polyethylene, exhaust muffler encases the entire center section of the drill (from handle to front-head end of the cylinder). Reducing exhaust noise improves the environment and contributes to greater operator productivity.

8. The standard JH40 Jackhammer is equipped with a yoke type steel holder (Figure 1-1) which is easily operated by hand, but can be released by foot. The steel holder is held in the fronthead by a bolt which rotates in a bore at the front end of the fronthead. A flat on the bolt engages a spring-loaded, nylon plunger to lock the holder in the closed position. The bolt, plunger, and spring are encased in the fronthead to protect them from dirt and grit.

9. When specially ordered, a beavertail type steel holder (Figure 1-2) will be furnished in place of the yoke type steel holder. This steel holder is designed for foot operation. It is supported at the front end where maximum abuse occurs. The steel holder eye bolts, which engage trunnions on the steel holder, are equipped with springs to cushion shocks and minimize breakage. The

steel holder bolt nuts are securely locked on the bolts by retaining rings fitted in grooves provided on the ends of the bolts. This method of locking the nut prevents thread wear as the nut is jammed against the threads. Replaceable bushings in the fronthead lugs take the steel holder and steel holder bolt wear.

10. The chuck consists of three pieces, viz., chuck, chuck driver, and chuck nut. This type of chuck lowers replacement costs as only the chuck is required when the broached hole for the steel is worn. The chuck driver and replaceable bronze chuck nut are fitted with reverse buttress type self-locking threads. The bronze chuck nut increases the service life of the piston flutes. It also prevents scoring of piston flutes caused by severe rotation strain.

## SECTION II OPERATION

### 2-1 AIR REQUIREMENTS

An air compressor of sufficient capacity is needed to provide the necessary volume of air at the most efficient operating pressure to assure effective and economical operation of the drill. Refer to Specifications (Para. 1-2) for air requirements of this drill.

#### 2-1.1 AIR PRESSURE AND VOLUME

Low or inadequate pressure at the drill is costly and wasteful, and an insufficient volume of air at the drill will not allow the machine to operate in the most efficient manner.

Air pressures of 621 to 689 kPa (90 to 100 psi) are recommended for maximum performance. These figures represent air pressures at the drill and not at the compressor. There is always a certain amount of line drop between the compressor and the drill; only the pressure and volume at the machine is effective in doing work. If hoses are relatively short and in good condition, pressure drop between the compressor (or air receiver) and drill should not exceed 15 percent of the initial pressure.

#### 2-1.2 AIR HOSES AND FITTINGS

Quality hose designed especially for rock drill service should be used. It should be constructed with an outer covering which resists abrasive wear; it should have an oil resistant inner tube; and it should be able to withstand the heat of the compressed air. It should have a working pressure safety factor of at least 4 to 1 in relation to burst.

The hose fittings should be kept as tight as possible and should be in good condition. Elimination of leakage involves making the air system tight and then keeping it tight. Air losses through bad connections and worn hose can often reach 10 to 20 percent of the total air compressed. Refer to Specifications (Para. 1-2) for size of air hose required.

### 2-2 WATER REQUIREMENTS

The water pressure for wet style machines should be maintained at about 69 kPa (10 psi) less than the air pressure. If water pressure exceeds air pressure, water will be forced into the machine and will carry away the lubricant. The water pressure should never fall below 276 kPa (40 psi).

### 2-3 SAFETY PRECAUTIONS

The following safety precautions must be observed at all times to prevent injury to the operator or co-workers:

#### DANGERS

1. WEAR SAFETY SHOES, SAFETY GLASSES, NOSE MASK, EAR PROTECTORS, HARD HAT, AND GLOVES.
2. DO NOT INDULGE IN HORSEPLAY.
3. KEEP HANDS OFF THE THROTTLE LEVER UNTIL READY TO START DRILLING.
4. MAINTAIN A STEADY BALANCE AT ALL TIMES.
5. NEVER GET YOUR FACE CLOSE TO THE DRILL.

6. NEVER REST THE DRILL ON YOUR FOOT.
7. NEVER POINT THE DRILL AT ANYONE.
8. NEVER START THE DRILL WHEN IT IS LYING ON THE GROUND.
9. COMPRESSED AIR IS DANGEROUS. NEVER POINT AN AIR HOSE AT YOURSELF OR CO-WORKERS. NEVER BLOW YOUR CLOTHES FREE WITH COMPRESSED AIR.
10. BE SURE ALL HOSE CONNECTIONS ARE TIGHT. A LOOSE HOSE NOT ONLY CAUSES LEAKS, BUT MAY COME COMPLETELY OFF THE DRILL, WHIP AROUND AND INJURE PERSONNEL IN THE AREA. ATTACH SAFETY CABLES TO ALL HOSES TO PREVENT INJURY IF A HOSE IS ACCIDENTALLY BROKEN.
11. NEVER ATTEMPT TO DISCONNECT A PRESSURIZED AIR HOSE. BEFORE DISCONNECTING A HOSE, SHUT-OFF THE AIR AT THE COMPRESSOR AND BLEED THE DRILL.
12. DO NOT OPERATE THE DRILL WITHOUT A DRILL STEEL SHANK IN THE FRONTHEAD. HOLD THE DRILL FIRMLY AGAINST THE WORK.
13. ALWAYS KEEP BOTH HANDS ON THE T-HANDLE WHILE OPERATING.
14. THE OPERATOR MUST SPREAD LEGS AND FEET CLEAR OF DRILL STEEL TO PREVENT INJURY IF A STEEL BREAKS. WHEN A STEEL BREAKS, THE DRILL (WITH PIECE OF BROKEN STEEL PROJECTING FROM FRONTHEAD) DROPS SUDDENLY TO THE GROUND.
15. NEVER USE YOUR BODY TO CONTROL AN ACTIVE DRILL. DO NOT "RIDE" THE DRILL WITH ONE LEG OVER THE HANDLE. THE OPERATOR CAN BE INJURED IF A STEEL BREAKS WHILE HE IS "RIDING" THE DRILL.
16. KNOW WHAT IS UNDERNEATH THE MATERIAL YOU ARE DRILLING. BE ALERT FOR ANY EXISTING WATER, GAS, ELECTRIC, SEWER, OR TELEPHONE LINES.
17. IF YOU HIT SOMETHING, SHUT-OFF THE DRILL IMMEDIATELY AND FIND OUT WHAT IT IS. USE A SHOVEL, NOT THE DRILL, TO UNCOVER THE OBJECT — CAREFULLY.

## 2-4 BEFORE OPERATION

1. Install an air line lubricator in the main air supply line, about 3.5 m (11.5 ft) from the drill.

### NOTE

A compressor lubricator can be used if the lead hose does not exceed 15 m (49.2 ft) in length.

2. Fill air line lubricator with rock drill oil conforming to the Specifications outlined in Table 3-1.
3. Blow out the air hose before connecting it to the drill. This rids the line of dirt, precipitation, and rubber particles.

### DANGER

WHEN BLOWING OUT AN AIR HOSE, HOLD IT FIRMLY AND POINT IT AWAY FROM PERSONNEL AND EQUIPMENT.

4. When using new air hose, blow lubricated air through the hose to completely coat the inside of the hose with oil. This may take from 10 to 15 minutes.
5. Pour one-half cup of rock drill oil into the hose before connecting it to the drill.
6. An air line filter can be installed in the main air supply line to keep dirt from entering the drill. Filters are an accessory item and must be specially ordered.
7. Connect the leader hose to the air connection on the drill.

### DANGER

BE SURE ALL HOSE CONNECTIONS ARE TIGHT. A LOOSE HOSE NOT ONLY CAUSES LEAKS BUT MAY COME COMPLETELY OFF THE DRILL, WHIP AROUND, AND INJURE PERSONNEL IN THE AREA. ATTACH SAFETY CABLES TO ALL HOSES TO PREVENT INJURY IF A HOSE IS ACCIDENTALLY BROKEN.

8. Check drill steels. The drill steel center hole should be open, and shanks should be flat and square—not chipped or rounded off. Be sure the shank of the steel is the proper length.
9. Be certain bits are properly ground. Dull bits are hard on the drill and on the operator.
10. Check tightness of the assembly rods. They must be tightened evenly and kept tight at all times. Torque the assembly rod nuts to 162.7 N·m (120 lb-ft) plus or minus 13.56 N·m (10 lb-ft).

## 2-5 OPERATING CONTROLS

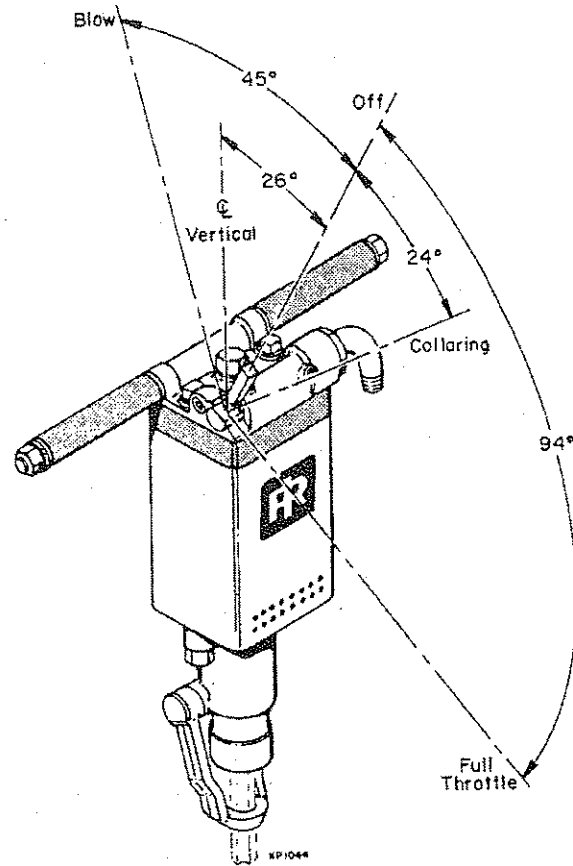

Figure 2-1. Operating Lever Positions for JH40 Jackhammer

## 2-6 OPERATION

### CAUTION

DO NOT OPERATE THE DRILL WITHOUT A DRILL STEEL SHANK IN THE FRONTHEAD. HOLD THE DRILL FIRMLY AGAINST THE WORK.

### DANGERS

1. KNOW WHAT IS UNDERNEATH THE MATERIAL YOU ARE DRILLING. BE ALERT FOR ANY EXISTING WATER, GAS, ELECTRIC, SEWER, OR TELEPHONE LINES.
2. ALWAYS KEEP BOTH HANDS ON THE T-HANDLE WHILE OPERATING.
3. THE OPERATOR MUST SPREAD LEGS AND FEET CLEAR OF DRILL STEEL TO PREVENT INJURY IF A STEEL BREAKS. WHEN A STEEL BREAKS, THE DRILL DROPS SUDDENLY TO THE GROUND.

Almost immediately after starting the drill, check for presence of oil at the exhaust ports and on the drill steel shank. This is the only assurance that oil is traveling all the way through the drill. Break in a new drill slowly using half throttle for at least the better part of an hour.

Heating is not unusual in a new drill and it should be checked carefully during the first few hours of operation. In most cases, heating will be localized around the piston stem bearing at the front end of the cylinder. Test this area frequently with the hand. As long as the hand can be held on the part comfortably, it is safe to continue drilling. When the heat is great enough to cause discomfort, stop the drill and let it cool. Since lack of oil can cause excessive heating, check again to see that the steel shank is oily.

#### 2-6.1 COLLARING THE HOLE

1. When starting the hole, hold the drill firmly against the work and use a steel short enough so that the drill can be handled comfortably.
2. Open the throttle gradually and drill at half throttle or less.
3. Make sure the bit is through the overburden and about 51 mm (2 in.) deep in the rock before using full throttle.
4. The drill should be kept at right angles to the work, until the hole is collared, then repositioned for angled drilling.

#### 2-6.2 DRILLING THE HOLE

1. Hold the drill with both hands, spread feet apart, and apply a firm steady pressure.

#### CAUTION

"RIDING" THE DRILL HANDLE CREATES AN EXCESS PRESSURE ON ONE SIDE OF THE DRILL AND THROWS THE DRILL OUT OF ALIGNMENT. MISALIGNMENT CAUSES A DRAG ON ROTATION PARTS AND INTERFERES SERIOUSLY WITH NORMAL ROTATION WHICH RESULTS IN IMPAIRED DRILLING EFFICIENCY BY REDUCING THE DRILLING SPEED AND FORCE OF THE BLOW.

MISALIGNMENT WILL ALSO CAUSE UNNECESSARY CHUCK WEAR, AND WILL SOON CAUSE SPALLING OF THE PISTON AND CHIPPING OR PREMATURE BREAKAGE OF THE DRILL STEEL.

#### WARNING

THE OPERATOR CAN BE SERIOUSLY INJURED IF A STEEL BREAKS WHILE HE IS RIDING THE DRILL WITH ONE LEG OVER THE HANDLE.

2. The correct amount of pressure for maximum drilling efficiency can be gained only through experience, but generally the correct pressure is usually recognizable by

the rhythmic sound of the exhaust and the free rotation of the steel.

3. Insufficient pressure will cause the drill to bounce and may crack carbide inserts.
4. Too much pressure will slow down the drill and may result in a stuck steel.
5. Keep the drill, steel, and hole aligned at all times.

#### 2-6.3 CLEANING THE HOLE

1. Always keep the hole clean and free of cuttings by blowing the hole frequently or using plenty of water with wet machines. The bit must work on fresh rock. If the bit churns in its own cuttings, drilling speed is reduced, and the possibility of the steel becoming stuck is increased.

#### CAUTION

WHEN THE BIT IS NOT PENETRATING THE ROCK FREELY, SEVERE LOADS BUILD UP BETWEEN THE FLUTES ON THE RIFLE BAR AND RIFLE NUT AND BETWEEN THE SPLINES ON THE PISTON AND CHUCK NUT. THIS LEADS TO MAJOR DAMAGE OF THESE PARTS AND AN EARLY BREAKDOWN.

#### 2-6.4 STUCK STEEL

When drilling moist formations there is often a tendency for cuttings to pack in the hole immediately behind the bit, forming a "mud-collar". Through action of the rotating bit, wet cuttings pack solidly against the wall of the hole; the condition can become aggravated and cause a stuck steel.

To remove a stuck steel:

1. Remove the drill and make an attempt to loosen the steel with a wrench.
2. Do not try to pull a stuck steel with the drill for more than a few minutes. Heavy thrust loads can damage front end parts.

To prevent a stuck steel:

1. Blow the hole often.
2. Keep drill working against fresh rock.
3. Raise bit from bottom of hole, and blow the hole clean before removing bits and steel.

#### 2-7 DRILLING TIPS

In order to assure maximum operating efficiency, the following suggestions should be observed:

##### 2-7.1 SUGGESTIONS FOR DRILLING

1. Never pound on stuck steel. Nothing is accomplished thereby, and the drill and bit may be permanently damaged in the process.
2. Never retract the drill at full throttle.
3. Never strike the drill with tools. The muffler or other parts may break or be damaged.
4. Never try to repair the drill on the job. Take it to a repair shop.
5. Never drag a drill along the ground; the exhaust port and other openings will scoop up dirt.

6. Always blow out the air supply hose before connecting it to the drill. This rids the line of dirt.

7. Always be sure drill is well lubricated. Adjust the air line lubricator so that the drill steel shank always shows an oil film but does not cause fogging.

8. Always keep rock drill oil in a sealed container so that it doesn't get contaminated with dust or dirt.

9. Always keep the assembly rods tight and at equal tension.

10. Always keep the drill aligned with the drill steel and hole.

11. Always keep plastic caps or plugs in all ports when the drill is not in service.

#### 2-7.2 DRILL STEEL CARE

1. It is very important that the threads of the drill steel be properly lubricated and cared for at all times. Steels having stripped threads, cracks, or severe galling must not be used. Also, care should be taken while drilling not to bend steel or gall threads due to misuse.

2. Bent steel produces unnecessary stresses and accelerates wear on fronthead components. Bent steel and severe thread galling can be avoided if the following steps are taken:

a. Be sure that the steel is bottomed in the bit.

b. All the threads must be in good condition and well greased.

c. Always drill with a sharp bit. Dull bits cause excessive pounding and unnecessary stresses on all threads and drill parts.

d. Never approach the rock with the drill running. Position carefully and collar the hole at reduced throttle. Once the bit is collared in rock, full throttle may be applied.

e. Always keep the drill "fed-up" to the work. Insufficient feed pressure will cause the bit to become loose on the steel and will damage the threads and cause inserts to tear loose.

f. Always maintain alignment between the drill and hole.

g. Never retract the drill at full throttle. Use part throttle.

#### 2-7.3 BIT CARE

For long bit life, the instructions as listed in Para. 2-7.2 covering Drill Steel Care must also be applied to the bit. In addition, the following steps must be taken:

1. Never allow the bit to become plugged with loose cuttings. Blow the hole continuously.

2. Never force or broach the bit into a hole.

3. Remove the bit from the steel with a Stillson or bit wrench. Never strike the bit with a hammer.

4. Never rough handle steels with bits on.

5. Never run a dull bit.

**Table 3-2. Trouble Shooting Chart**

Trouble	Probable Cause	Remedy
Drill will not start.	<ol style="list-style-type: none"> <li>1. Plugged exhaust ports.</li> <li>2. Stuck valve due to gummy oil.</li> <li>3. Frozen piston due to improper lubrication.</li> <li>4. Assembly rods tightened unevenly, causing binding.</li> </ol>	<ol style="list-style-type: none"> <li>1. Dismantle drill and clean out all ports and air passages. (Refer to par. 3-3).</li> <li>2. Remove valve chest complete. (Refer to par. 3-3.2 [24]. Dismantle valve and clean parts. Never use dirty oil nor oil that does not conform to the recommended specifications (par. 3-1).</li> <li>3. Dismantle drill to remove piston. Repair piston by placing in high speed lathe and dressing with fine emery cloth. Never run drill without proper lubricating oil in the line lubricator.</li> <li>4. Check drill for correct assembly and retighten assembly rods evenly. Torque assembly rod nuts to 162.7 N•m (120 lb-ft) plus or minus 13.56 N•m (10 lb-ft).</li> </ol>
Drill loses power rapidly.	<ol style="list-style-type: none"> <li>1. Restriction in supply line.</li> <li>2. Air hose too long.</li> <li>3. Diameter of air supply line too small.</li> </ol>	<ol style="list-style-type: none"> <li>1. Remove all kinks or sharp bends in the air supply line.</li> <li>2. Keep hose as short as possible. As a general rule, keep the air supply line under 50 ft (15.23 m).</li> <li>3. Refer to Specifications (par. 1-2) for correct size of air hose.</li> </ol>
Drill lacks power.	<ol style="list-style-type: none"> <li>1. Low air supply pressure.</li> <li>2. Running on fronthead cushion.</li> <li>3. Plugged air passages.</li> <li>4. Lack of lubricating oil.</li> <li>5. Short drill steel shank due to wear or regrinding.</li> <li>6. Ice build-up in muffler, restricting exhaust.</li> </ol>	<ol style="list-style-type: none"> <li>1. The air supply pressure at the drill inlet must be 552 to 689 kPa (80-100 psi). Check compressor discharge pressure.</li> <li>2. Maintain a constant pressure on the drill and keep the bit fed-up to the work.</li> <li>3. Dismantle drill and clean out all ports and air passages.</li> <li>4. Drill is receiving adequate lubrication when a thin film of oil can be detected along the shank end of the steel. Check air line lubricator and refill if necessary.</li> <li>5. Replace drill steel if shank is excessively worn.</li> <li>6. Eliminate condensation in air supply.</li> </ol>
No steel rotation or rotation is weak.	<ol style="list-style-type: none"> <li>1. Steel binding in hole.</li> <li>2. Worn rotation parts; pawls, ratchet, rifle bar, chuck nut, etc.</li> </ol>	<ol style="list-style-type: none"> <li>1. Apply correct amount of downpressure and keep drill, steel and hole in alignment. Replace worn bits.</li> <li>2. Disassemble drill and replace worn parts (par. 3-3).</li> </ol>
Overheating (new drill)	<ol style="list-style-type: none"> <li>1. New drill may overheat at piston stem bearing.</li> </ol>	<ol style="list-style-type: none"> <li>1. Run new drill at less than full throttle until broken in; adjust air line lubricator to provide an adequate supply of lubricating oil.</li> </ol>
Overheating after break-in period.	<ol style="list-style-type: none"> <li>1. Running on fronthead cushion.</li> <li>2. Piston not hitting shank because of short shank.</li> <li>3. Pulling steel at full throttle.</li> <li>4. Lack of lubrication or improper lubricating oil.</li> </ol>	<ol style="list-style-type: none"> <li>1. Apply adequate down-pressure on drill to keep bit fed-up.</li> <li>2. Replace drill steel if shank is worn or has been shortened by regrinding. Refer to Specifications (par. 1-2) for correct size of shank.</li> <li>3. Use as little throttle as possible when pulling steels to avoid running on cushion.</li> <li>4. If drill is receiving adequate lubrication a thin film of oil can be detected on steel shank. Check oil level in air line lubricator; refill if necessary (par. 3-1).</li> </ol>
Slow drilling speed.	<ol style="list-style-type: none"> <li>1. Dull bit.</li> <li>2. Cuttings not being removed from hole.</li> <li>3. Plugged drill steel or blower tube.</li> <li>4. Drill and steel not aligned with hole; steel or bit binding in hole.</li> <li>5. Insufficient down-pressure.</li> </ol>	<ol style="list-style-type: none"> <li>1. Replace bit.</li> <li>2. Use blow air frequently to keep bit working on fresh rock.</li> <li>3. Remove tube and drill steel; clean out air passages.</li> <li>4. Check alignment while drilling to prevent binding and to avoid stuck steel.</li> <li>5. Increase down-pressure.</li> </ol>
Erratic or sluggish operation.	<ol style="list-style-type: none"> <li>1. Lubricating oil too heavy—slowing down valve action.</li> <li>2. Gummed oil or dirt in operating parts.</li> </ol>	<ol style="list-style-type: none"> <li>1. Use recommended oil of proper viscosity for ambient temperature (par. 3-1.1).</li> <li>2. Dismantle drill (par. 3-3) and clean out dirt and gummy residues. Service drill with clean oil. Protect the tool from dirt when idle.</li> </ol>

## SECTION III MAINTENANCE

### 3-1 LUBRICATION

Proper lubrication is the most important single factor responsible for the service life of the pneumatic drill. A drill can be severely damaged during the first few minutes of operation if not properly lubricated.

Lubrication of the internal working parts of the drill is automatically supplied by an air line lubricator, which feeds a controlled, constant flow of oil into the air supply to the rock drill. An air line lubricator must be used with each individual drill. It should be placed in the main air line about 3.5 m (11.5 ft) from the drill.

Service the lubricator with the correct rock drill oil as frequently as necessary to prevent any possibility of the drill running dry. Generally, the supply of oil in the lubricator should be checked every two hours of drilling time.

Every effort must be made to avoid oil contamination from dirt or other impurities. Oil should be kept in covered containers, and stored, if possible, in an area that is relatively dust free.

Before filling the lubricator the area around the filler plug should be wiped clean.

To adjust the air line lubricator initially:

1. Turn the lubricator needle valve clockwise until it is completely closed, and then turn the valve counterclockwise about 3/4 of a turn off its seat.
2. Almost immediately after starting the drill, check for presence of oil at the exhaust ports and on the drill steel shank. This is the only assurance that oil is travelling all the way through the drill.
3. Fine-tune the lubricator needle valve to provide a light film of oil on the steel shank and a fine oil mist coming from the exhaust ports. If there's blue smoke coming

from the exhaust ports or oil running down the steel, the drill is getting too much oil. Adjust lubricator for proper rate of feed.

#### 3-1.1 LUBRICATING OIL SPECIFICATIONS

Rock Drill Oil, formulated specifically for pneumatic drills, is available. This oil possesses certain desirable characteristics which prolong the service life of the drill and provide protection against rust and corrosion when the tool is stored.

It is recommended that oils of this class be used in the air line lubricator in order to obtain maximum performance of the tool. Table 3-1 lists the specifications of this oil.

In addition to meeting the specifications in Table 3-1, the Rock Drill Oil must perform satisfactory in the drill. The responsibility for meeting these specifications, the quality of the product, and its performance in service must necessarily rest with the oil supplier.

The use of oil not conforming to our specifications will prove very harmful to the drill. Harmful effects will result when:

- a. Oil with low flash point is used, which is conducive to "dieseling".
- b. Reclaimed oil which is not of proper consistency and stringiness is used.

#### 3-2 TROUBLE SHOOTING

The operating troubles outlined in Table 3-2 must not be construed as an indication of the operating difficulties to be expected. If the drill is operated and serviced properly, the only troubles that will develop will be due to normal wear associated with long hard service.

**Table 3-1. Rock Drill Lubricating Oil Specifications**

The Rock Drill Oil used in the air line lubricator must be a well refined petroleum lubricating oil. It must be suitably compounded to provide the specified consistency and film strength, and be further compounded to provide the specified steam emulsion number. The latter is required to provide a satisfactory lubricant for such drills where water or wet air is encountered. The oil must also be substantially non-corrosive to steel and bronze, and contain little or no sulphur.

Characteristics	Method	Below 20° F (-6.7° C) Light	20-90° F (-6.7° C to 32.2° C) Medium	Above 90° F (32.2° C) Heavy
Viscosity:				
SUS at 100° F (37.8° C)	ASTM-D2161	175 Min.	450 Min.	750 Min.
SUS at 210° F (98.9° C)	ASTM-D2161	46 Min.	65 Min.	85 Min.
cSt at 40° C	ASTM-D445	37 Min.	105 Min.	160 Min.
cSt at 100° C	ASTM-D445	6 Min.	11 Min.	16 Min.
Flash Point, °F (°C) Min.	ASTM-D92	370 (188)	400 (204)	450 (232)
Pour Point, °F (°C) Max.	ASTM-D97	-10 (-23)	-10 (-23)	0 (-18)
Viscosity Index, Min.	ASTM-D2270	90	90	90
Steam Emulsion No., Min.	ASTM-1935-65	1200	1200	1200
Consistency		Stringy	Stringy	Stringy
Falex Load Test lbs (Min.)	ASTM-D2670	2000	2000	2000
Timken E.P. Test lbs (Min.)	ASTM-D2782	30	30	30

The composition of the "film strength" additive is not specified. The additive must be suitable for use with both steel and bronze, and be substantially non-corrosive to both metals. Except for consistency, all tests must be conducted in accordance with the standard method (latest edition) of the American Society for Testing Materials.

**Table 3-2. Trouble Shooting Chart (cont'd)**

Trouble	Probable Cause	Remedy
Stuck steel.	<ol style="list-style-type: none"> <li>1. Driving steel after bit is dull or has lost its gauge.</li> <li>2. Crowding bit in soft formations.</li> <li>3. Cuttings not being blown from hole.</li> <li>4. Misalignment of steel with hole causing binding.</li> </ol>	<ol style="list-style-type: none"> <li>1. Don't force a dull bit; sharpen or replace with new bit.</li> <li>2. Use down-pressure cautiously in soft formations; be certain steel is rotating freely.</li> <li>3. Use blow air frequently.</li> <li>4. Keep drill, steel and hole in alignment at all times.</li> </ol>
Chipping or breakage of piston.	<ol style="list-style-type: none"> <li>1. Bad drill steel shank which is too hard or rounded on end allowing minimum contact with piston striking face.</li> <li>2. Worn chuck which permits steel to cock in chuck so that piston strikes shank a glancing blow.</li> <li>3. Heat cracking due to faulty lubrication.</li> <li>4. Failure in neck of piston due to loss of fronthead cushion; piston striking piston stem bearing.</li> </ol>	<ol style="list-style-type: none"> <li>1. Take bad shanks out of service—one bad shank can ruin many pistons.</li> <li>2. Replace worn chuck. Refer to par. 3-3.3, [12] and [13].</li> <li>3. Keep machine well lubricated with proper type of oil (par. 3-1).</li> <li>4. Check cylinder, piston and piston stem bearing sleeve for maximum wear tolerances. Refer to par. 3-3.3, [9], [10] and [11].</li> </ol>
Side rod breakage.	<ol style="list-style-type: none"> <li>1. Uneven tension on rods, or loose rods.</li> <li>2. Loss of fronthead cushion which allows piston to strike piston stem bearing with hard impact.</li> </ol>	<ol style="list-style-type: none"> <li>1. Keep side rods tight and at even tension; tighten rods alternately. Refer to par. 3-3.5, [16].</li> <li>2. Replace worn cylinder, piston or piston stem bearing sleeve. Refer to par. 3-3.3, [9], [10] and [11].</li> </ol>
Broken or battered tube.	<ol style="list-style-type: none"> <li>1. Blower tube breaking in drill steel shank.</li> <li>2. Worn chuck, which permits misalignment, chafing or bending of tube.</li> </ol>	<ol style="list-style-type: none"> <li>1. Check center hole in drill steel shank to be certain that hole is large enough and deep enough to accept tube.</li> <li>2. Replace worn chuck. Refer to par. 3-3.3, [12] and [13].</li> </ol>
Freezing at exhaust ports.	<ol style="list-style-type: none"> <li>1. Excessive moisture in air supply—usually occurs in low ambient temperatures.</li> </ol>	<ol style="list-style-type: none"> <li>1. Install moisture traps in air lines or use anti-freeze lubricant (e.g. Kilfrost) in the air line lubricator, as required.</li> </ol>
Fogging.	<ol style="list-style-type: none"> <li>1. Excessive moisture in air supply.</li> <li>2. Over-lubrication.</li> </ol>	<ol style="list-style-type: none"> <li>1. Blow out air lines. If moisture traps are installed in the air supply line, drain the moisture.</li> <li>2. Adjust air line lubricator for proper rate of feed.</li> </ol>

**3-3 DISASSEMBLY, INSPECTION, AND REASSEMBLY**

**3-3.1 PRELIMINARY DISASSEMBLY INSTRUCTIONS**

1. Never attempt extensive maintenance or major repair on the drill in the field; always send the drill to the shop.
2. Clean the exterior of the drill before tearing it down.
3. Provide a clean work area for disassembling the drill.
4. If necessary, use a rubber mallet to loosen the fronthead and handle. Use a brass bar or soft drift for removing interior parts.
5. Handle parts carefully. Hardened parts might chip or break if dropped on a hard surface.
6. Place small parts in a clean box to prevent loss.

**3-3.2 DISASSEMBLY**

Two construction variations of the JH40 Jackhammer are available:

- a. Standard—JH40 with Yoke Type Steel Holder Construction (Refer to Figure 3-1).
- b. Optional—JH40 with Beavertail Type Steel Holder Construction (Refer to Figure 3-2).

The following disassembly instructions cover both JH40 constructions, except where noted.

1. Secure the drill firmly in a vise.



**WHEN CLAMPING THE DRILL, DO NOT EXERT EXTREME PRESSURE ON THE TOOL PARTS CAN BE CRACKED OR DAMAGED IF THE VISE IS TIGHTENED TOO MUCH.**

2. Remove the assembly rod nuts (2) and assembly rods (1) and carefully pull the handle assembly and blower tube assembly away from the drill.
3. Place the handle assembly on a clean work bench.
4. Unscrew the tube retainer (3), and pull the blower tube (5) out of the handle (8).
5. If necessary, remove the "O" ring (4) from the tube retainer (3).
6. Examine the tube rubber (6), and if worn or damaged, discard the rubber.

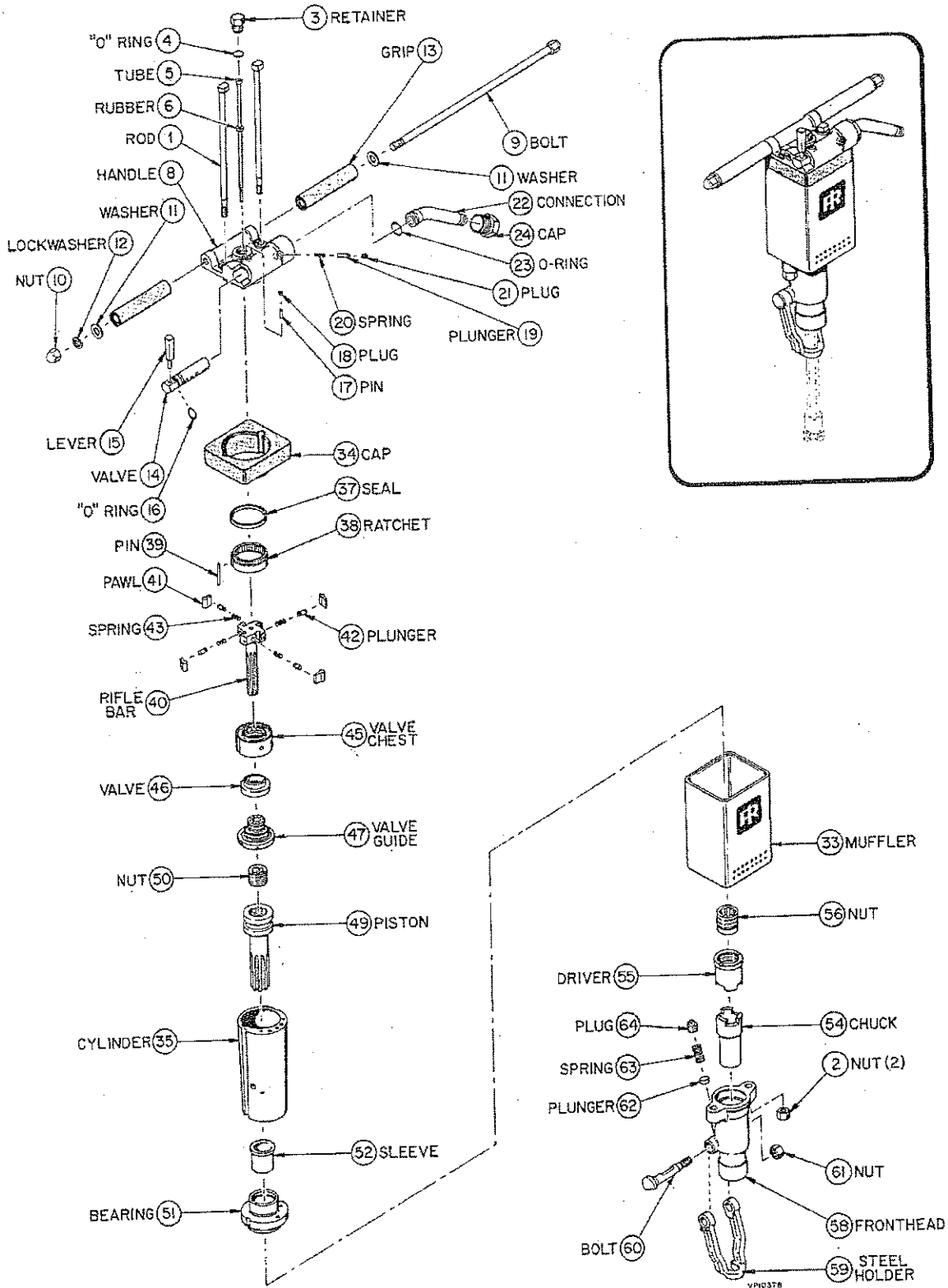

Figure 3-1. JH40 Jackhammer (Yoke Type Steel Holder)

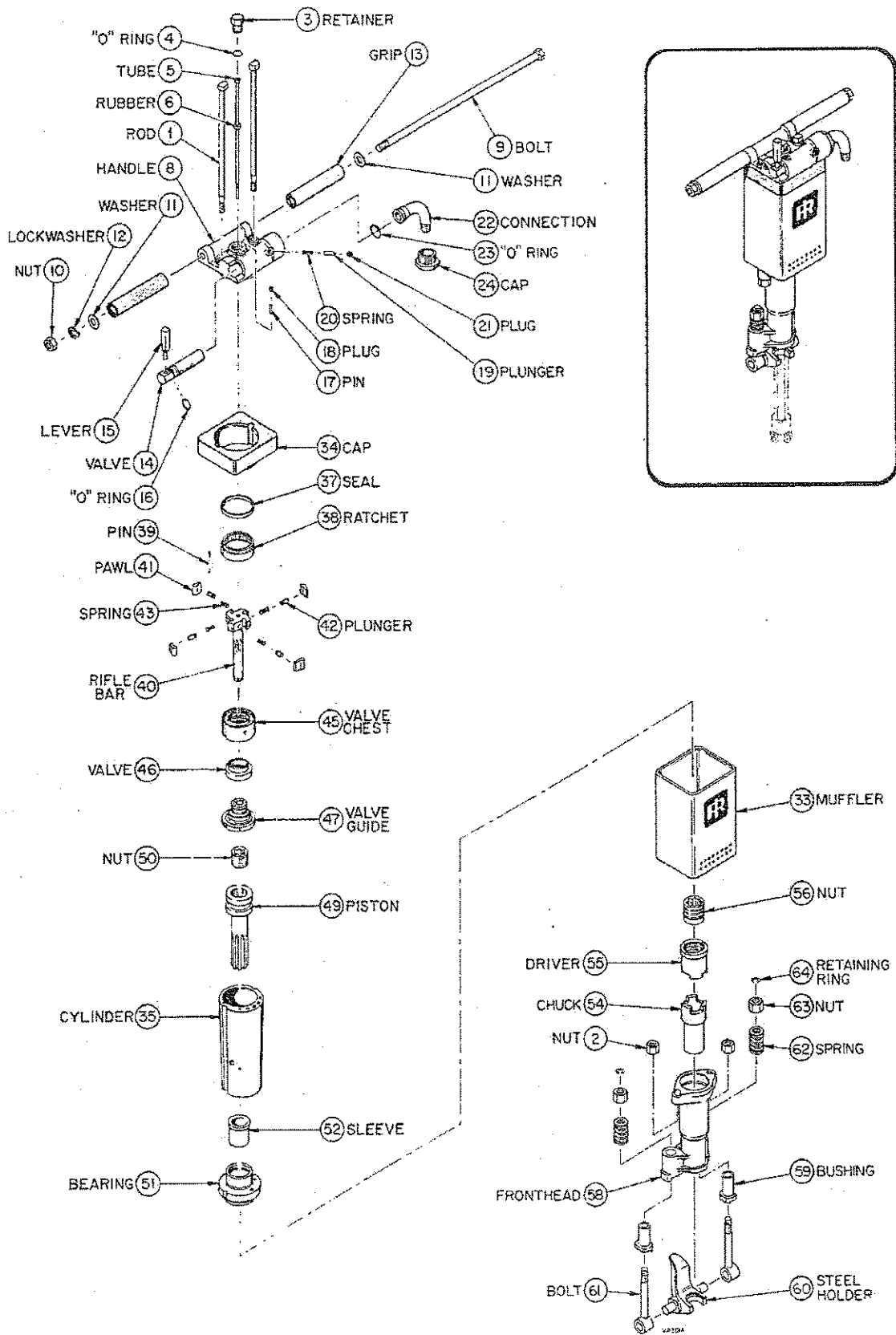

Figure 3-2. JH40 Jackhammer (Beavertail Type Steel Holder)

7. Remove the plug (18), and locating pin (17) from the handle. A small hole is provided in the underside of the handle to assist in removing the pin (17).

8. Use the lever (15) to pull the throttle valve (14) from the handle (8).

#### NOTE

The throttle lever (15) is press-fitted in the throttle valve (14). Do not remove the lever from the valve unless replacement of the lever or valve is necessary.

9. If necessary, remove the "O" ring (16) from the throttle valve (14).

10. Unscrew the air connection cap (24) and remove the air hose connection (22).

11. If necessary, remove the "O" ring (23) from the air connection (22).

12. Unscrew the handle bolt nut (10). Remove the nut and lockwasher (12).

#### NOTE

The handle bolt (9) is designed with an identical nut on each end, however the nut (10) that seats the lockwasher (12) is removable, while the nut on the opposite end (no lockwasher) is permanently assembled to the handle bolt. Do not attempt to remove the permanently assembled nut (refer to figure 3-1 or figure 3-2).

13. Slide the handle grip washer (11) and handle grip (13) from the handle bolt (9).

14. Remove the handle bolt [with remaining handle grip washer (11) and handle grip (13)] from the handle (8).

15. Pull the fronthead (58) with chuck and steel holder parts off the piston stem bearing (51).

16. Place the fronthead assembly on a clean work bench.

17. Drive the chuck (54) and chuck driver (55) with chuck nut (56) out of the fronthead assembly.

18. Clamp the chuck driver (55) in a vise.

19. The chuck nut (56) can be removed from the chuck driver (55) by using a tool made from an old piston. Cut-off the old piston stem and weld a hex. nut to the stem.

20. Insert the fabricated tool in the chuck nut (56) and turn clockwise to remove.

#### NOTE

The chuck nut has left-hand threads

21. Steel Holder Removal (For JH40 with Yoke Type Steel Holder—Refer to Figure 3-1):

a. Move steel holder to the closed position.

b. Remove the plug (64), spring (63), and plunger (62).

c. Unscrew the nut (61) and remove the bolt (60) and steel holder (59).

22. Steel Holder Removal (For JH40 with Beavertail Type Steel Holder—Refer to Figure 3-2):

a. Tighten the steel holder bolt nuts (63) and remove the steel holder bolt nut retaining rings (64).

b. Unscrew and remove the steel holder bolt nuts (63), and slide the steel holder springs (62) off the steel holder bolts (61).

c. Slide the steel holder bolts (61) and steel holder (60) out of the fronthead (58).

d. If worn, drive the steel holder bolt bushings (59) out of the fronthead lugs.

23. Remove the muffler cap (34) and slide the muffler (33) from the cylinder (35).

24. Insert a brass bar in the front end of the cylinder until it makes contact with the end of the piston stem, and force the piston to drive the valve chest assembly and rotation parts (rifle bar, ratchet, pawls, etc.) out the rear end of the cylinder.

#### CAUTION

THE ROTATION PAWLS, PLUNGERS, AND SPRINGS WILL FALL OUT OF THE RIFLE BAR HEAD WHEN THE HEAD IS CLEAR OF THE CYLINDER.

25. Remove the four pawls (41), plungers (42), and springs (43).

26. Remove the rifle bar (40) from the ratchet (38).

27. Remove the locating pin (39) and seal (37) from the ratchet (38).

28. Remove the piston (49) from the front end of the cylinder (35).

29. To remove the rifle nut (50) from the piston:

a. Hold the piston in a vise

b. Insert an *old* rifle bar in the rifle nut and turn clockwise to unscrew (the rifle nut has left-hand threads).

#### NOTE

The old rifle bar may require several good blows with a copper hammer to loosen the rifle nut. Block-up under the head of the old rifle bar before striking it to prevent it from breaking.

30. Press the piston stem bearing (51) out of the cylinder.

31. If worn and replacement is necessary, press the piston stem bearing sleeve (52) out of the piston stem bearing (51). The sleeve is press-fitted in the bearing, and should not be removed unless replacement is necessary.

### 3-3.3 INSPECTION AND REPAIR OF PARTS

1. Clean disassembled parts in a suitable solvent

#### DANGER

WHEN USING ANY SOLVENT TO CLEAN PARTS, MAKE SURE THAT IT IS NON-FLAMMABLE, THAT IT WILL NOT HARM THE SKIN, THAT IT MEETS CURRENT SAFETY AND HEALTH STANDARDS, AND THAT IT IS USED IN AN AREA THAT IS ADEQUATELY VENTILATED.

2. Replace the rifle bar or rifle nut if the flutes are worn approximately 1.6 mm (1/16 in.). If a 3.2 mm (1/8 in.) shim can slide between the sides of the flutes of the rifle bar and rifle nut, either one, or both, is excessively worn.

3. The rotation pawls can be reversed when the edges on one side become rounded. When the edges on both sides have rounded to approximately 1.6 mm (1/16 in.) radius, the pawls should be replaced.

4. Replace weak pawl plunger springs.

5. Replace the rotation ratchet when the teeth are rounded to 1.6 mm (1/16 in.) radius.

6. When a 0.076 mm (.003 in.) feeler gauge can be inserted between the valve and valve guide, or between the valve and valve chest, one or both parts are worn and should be discarded. To determine which part is excessively worn, various combinations of new valve parts should be assembled. The worn parts can be determined by means of a feeler gauge.

7. To check for a sticky valve, clean the valve parts and assemble the valve chest complete without oil. Shaking the chest should cause a clicking sound as the valve moves back and forth. If the clicking cannot be heard the sticky valve must be replaced.

Be sure to disassemble and oil the valve parts before reassembling for operation.

8. Examine the piston and rifle bar for heat checks resulting from improper lubrication. If heat checked, replace these parts in order to prevent damage to other parts.

9. Check the cylinder and piston for wear by inserting a 0.178 mm (.007 in.) feeler gauge between them. To determine whether the piston or cylinder is worn, insert a new piston in the cylinder, and check the clearance with a feeler gauge.

10. Check the piston periodically, to be sure that the striking face is in proper condition at all times. If cupped, it can be refaced by grinding. Re grind the striking face flat and square without burning. Remove as little metal as possible and not more than 1.6 mm (1/16 in.). This is the limit which will insure a hard striking face.

If the striking end of the piston is cupped, check the shanks of the steels that were used to be sure the striking ends are flat and square.

11. Replace the piston stem bearing sleeve when a 0.178 mm (.007 in.) feeler gauge can be inserted between the piston stem and the sleeve.

12. Replace the chuck nut when the flutes in the nut are worn approximately 1.6 mm (1/16 in.).

13. Replace the chuck when the ends of the chuck bore are worn to the extent that the drill steel shank cocks in the drill assembly. When the chuck is worn, the drill steel can no longer be held in line with the piston, and the loss of support for the shank allows the piston to strike the shank on an angle, damaging the piston, shank, and tube.

### 3-3.4 PRELIMINARY REASSEMBLY INSTRUCTIONS

1. Keep hands and tool free of dirt.
2. Wipe a film of clean oil over all working parts as they are assembled.
3. Do not allow dirt or chips from the soft hammer to enter the machine.

4. Except for press-fits, parts should fit together easily. If force is required, a part is out of alignment and must be corrected to prevent binding and damage.

### 3-3.5 REASSEMBLY

#### NOTE

Refer to Figure 3-1 for JH40 with Yoke Type Steel Holder, and to Figure 3-2 for JH40 with Beavertail Type Steel Holder. The following reassembly instructions cover both JH40 constructions, except where noted.

1. Press the piston stem bearing sleeve (52) into the piston stem bearing (51).

2. Align the assembly rod half-holes in the piston stem bearing flanges with the half-holes in each side of the cylinder body and press the piston stem bearing (51) into the cylinder (35). This is a tight fit; make sure the bearing is started squarely and that the cylinder is supported.

3. Screw the rifle nut (50) into the piston and slide the piston into the cylinder.

#### NOTE

The rifle nut has left hand threads; turn counter-clockwise when installing in piston. Use an old rifle bar as a wrench to tighten rifle nut.

4. To reassemble the valve chest assembly:

- a. Install the valve (46) over the valve guide stem (47).
- b. Install the valve chest (45) on the valve guide (47)

#### NOTE

Make sure the valve is free; check by shaking the valve chest. The valve should click open and shut when free of oil. After the clicking noise is noted, oil the valve.

5. Insert the rotation ratchet dowel pin (39) in the groove provided in the O.D. of the valve chest (45). Install the complete valve chest assembly in the cylinder (35) aligning the rotation ratchet dowel pin (39) with its groove in the cylinder.

6. To reassemble the rotation parts:

a. Place one rotation pawl plunger spring (43) and one rotation pawl plunger (42) in each of the four holes in the rifle bar (40).

b. Slip one rotation pawl (41) into each of the pawl housings in the rifle bar (40).

c. Compress the four rotation pawls (41) and slip the rotation ratchet (38) over the pawls.

7. Align the dowel pin groove in the ratchet (38) with the dowel pin (39) already in place in the cylinder (35) and slide the rotation assembly into the cylinder.

8. Install the muffler cap (34) on the handle end of the cylinder (35).

9. Slide the muffler (33) over the cylinder so that it seats against the muffler cap at the back end and on the piston stem bearing at the front end.

10. Screw the chuck nut (56) into the chuck driver (55).

#### NOTE

The chuck nut is fitted with left hand threads; turn counter-clockwise to screw chuck nut into driver.

An old piston can be used to tighten the chuck nut.

11. Slide the chuck (54) and chuck driver assembly into the fronthead (58).
12. Align the assembly rod holes in the fronthead flange with the half-holes in the cylinder and piston stem bearing and slide the fronthead (58) into position.
13. Reassemble the handle assembly:
  - a. Install the new "O" ring (16) in its groove in the throttle valve.
  - b. If removed, press the throttle valve lever (15) in the throttle valve (14).
  - c. Install the throttle valve assembly in the handle (8).
  - d. Insert the throttle valve locating pin (17) in its hole in the rear of the handle to secure the throttle valve in the handle.
  - e. Install the plug (18).
  - f. Install one set of handle grip parts on the handle bolt (9): Slide the washer (11) and grip (13) into the handle bolt (9) in order listed.
  - g. Insert the handle bolt (9) through the handle (8).
  - h. Install the remaining grip (13) and washer (11) over the projecting end of the handle bolt (9).
  - i. Install the lockwasher (12) and secure the handle with the nut (10).
  - j. Install a new "O" ring (23) in its groove on the hose connection (22).
  - k. Position the hose connection in the handle inlet port and secure by screwing the hose connection cap into the handle.
14. Position the handle assembly over the cylinder (35); align the assembly rod holes in the handle with the half-holes on each side of the cylinder body, and slide the handle (8) into the cylinder (35).
15. Slide the assembly rods (1) through the holes in the handle (8), half-holes in cylinder (35) and piston stem bearing (51), and through the holes in the fronthead flanges (58).
16. Secure the Jackhammer assembly by attaching assembly rod nuts (2).

#### CAUTION

THE ASSEMBLY RODS MUST BE TIGHT AND UNDER EQUAL TENSION. LOOSE OR UNEQUAL ASSEMBLY ROD TENSION WILL CAUSE MISALIGNMENT OF THE INTERNAL PARTS WHICH WILL PROMOTE BREAKDOWN OF THE DRILL. APPLY 162.7 N·m (120 LB-FT) OF TORQUE (PLUS OR MINUS 13.56 N·m [10 LB-FT]) TO EACH ASSEMBLY ROD NUT.

17. Slide the blower tube (5) through the hole in the tube rubber (6) until rubber is seated under tube collar.

18. Push the blower tube/rubber assembly through the tube hole in the handle (8) and through the center hole in the rifle bar and piston until the rubber seats in the counterbore in the handle.

19. Install a new "O" ring (4) on the tube retainer (3) and screw the retainer (3) into the handle to secure the tube.

20. Steel Holder Reassembly (For JH40 with Yoke Type Steel Holder—Refer to Figure 3-1):

- a. Attach the steel holder to the fronthead by inserting the bolt (60) through the steel holder arm (and fronthead) so that the flat on the bolt head seats against the bolt stop on one arm. Be sure the holder (59) is positioned correctly—the open side of the yoke must face toward the backside of the tool (see figure 3-1).

- b. Screw the nut (61) onto the steel holder bolt (60).
- c. Position the holder in the closed position.
- d. Install the plunger (62) and spring (63) in that order.

- e. Compress the spring (63) and install the plug (64).

21. Steel Holder Reassembly (For JH40 with Beaver-tail Type Steel Holder—Refer to Figure 3-2):

- a. Press the steel holder bolt bushings (59) into the lugs of the fronthead (58).

- b. Place the steel holder bolts (61) on the steel holder trunnions.

- c. Position the steel holder and bolt assembly so that the bolts protrude through the fronthead lugs.

- d. Place the steel holder bolt springs (62) over the steel holder bolts (61) and secure by attaching the steel holder bolt nuts (63).

- e. Compress the springs (62) by tightening the nuts (63) until the retaining rings (64) can be inserted in the grooves in the steel holder bolts (61).

- f. Back-off the steel holder bolt nuts (63) until they rest against the retaining rings (64).

#### 3-4 PERFORMANCE TESTING

A reconditioned drill should be tested before it is sent back to the job. Before connecting the air hose, check to see that the air line lubricator is filled with the proper lubricant. Refer to Para. 3-1.

Pour a small amount of rock drill oil directly into the air inlet, for initial lubrication. The drill should start with little air pressure, with the piston reciprocating smoothly.

Let the machine run-in slowly at reduced pressure long enough to see that it is in good working order. If the drill stalls, turn off the air immediately. This indicates binding due to tight fits or perhaps unevenly tightened assembly rods. Check rod tension first, then start the machine again. After a short period of operation, a definite rhythm should develop and an even exhaust note will be heard. The drill may become warm but should not overheat. If erratic operation or stalling persists, disassemble the machine and check for binding parts.

After the initial period of low pressure operation, check the performance of a reconditioned drill with that of a new drill by comparing its speed under similar conditions and with normal air pressure. Once testing is completed, install plastic plugs or caps in all ports to keep out dirt until the machine is back in service.

**U.S. CONSTRUCTION EQUIPMENT GROUP OFFICES**

<b>Atlanta</b> 111 Ingersoll-Rand Drive Chamblee, GA 30341	<b>East Manover, NJ 07936</b> 93 Route # 10	<b>Knoxville, TN 37922</b> 111 Center Park Drive—Suite 900	<b>New England</b> 300 Turnpike Rd.—Route 9 Southboro, MA 01772	<b>Pico Rivera, CA 90560</b> 5211 Paramount Blvd.
<b>Casper, WY 82501</b> 7301 West Yellowstone Highway	<b>Elkridge, MD 21227</b> P.O. Box 7494 5281 Main Street	<b>Mid-Atlantic</b> 600 Greenlee Road Pittsburgh, PA 15220	<b>Odessa, TX 79762</b> 3248 Kermit Highway	<b>Portland, OR 97214</b> 240 South East Clay Street
<b>Chicago, IL</b> 12311 West Silver Springs Dr. Milwaukee, WI 53225	<b>Florida</b> 410 Ware Blvd.—Suite 202 Tampa, FL 33619	<b>Milwaukee, WI 53225</b> 12311 West Silver Springs Dr.	<b>Philadelphia</b> P.O. Box 397 Route 309 Montgomeryville, PA 18936	<b>San Leandro, CA 94577</b> 1944 Marina Blvd.
<b>Denver, CO 80207</b> 5805 East 39th Ave.	<b>Houston, TX 77001</b> 2210 McAllister	<b>New Cumberland, PA 17070</b> Drawer 878 Exit 15 on Rt. 89 4 miles south of Harrisburg	<b>Phoenix, AZ 85007</b> 820 N. 17th Ave.	<b>Scranton, PA 18505</b> 605 Davis St. P.O. Box 1147
				<b>St. Louis, MO 63132</b> 1516 Page Industrial Blvd.

**CANADA**

<b>Ingersoll-Rand Canada Inc.</b> Montreal, Quebec H3B 1S6 630 Dorchester Blvd. West	<b>Calgary, Alberta T2R 0E1</b> 611 11th Ave. SW <b>Don Mills, Ontario M3B 2V1</b> 255 Lesmill Road	<b>Montreal, Quebec</b> 620 Cathcart St. H3B 1M2 P.O. Box 1149 H3B 3K9	<b>Sudbury, Ontario P3A 3T3</b> 441 Emdynow Rd.	<b>Vancouver, British Columbia V6A 2W7</b> 1888 Main St.
--	--	--	--	---

**AUTONOMOUS COMPANIES**

<b>Argentina, Buenos Aires</b> Ingersoll-Rand Argentina S. A. I. y C. Casilla Correo 2412, Correo Central	<b>France, 78 190 Trappes Yvelines</b> Compagnie Ingersoll-Rand Avenue Albert Einstein Zone Industrielle	<b>Kenya, Nairobi</b> Ingersoll-Rand Mid Africa P.O. Box 14240	<b>Peru, Lima</b> Ingersoll-Rand Co. of Peru, S.A. Casilla 2261
<b>Australia, South Melbourne</b> Ingersoll-Rand (Australia) Ltd. 42 Moray Street, 3205 Victoria	<b>Germany, 403 Ratingen</b> Ingersoll-Rand GmbH Rohr. Zapp Str. 7 Postfach 1380	<b>Japan, 106 Tokyo</b> Ingersoll-Rand (Japan) Ltd. Kowa Bldg. No. 17 2-7 Nishi-Azabu 1-Chome Minato-Ku	<b>Philippines, Makati, Metro Manila 3117</b> Ingersoll-Rand Philippines, Inc. P.O. Box 445 MCC
<b>Austria A 1120, Vienna</b> Ingersoll-Rand Ges M. B. H. Schoenbrunnerstrasse 213-215 2 5	<b>Greece, Athens 610</b> Ingersoll-Rand Cent. Middle East 17th Floor Athens Tower Mesogion Z-4	<b>Malaysia, Petaling Jaya</b> Ingersoll-Rand Malaysia Sdn. Bhd. P.O. Box 125	<b>Portugal, Lisbon</b> Lisbon-Rand Lda. Apartado 24 Carnaxide, Portugal
<b>Bahrain, Manama</b> Ingersoll-Rand Bahrain (Manama) P.O. Box 5797	<b>Hong Kong</b> Ingersoll-Rand Far East 19th Floor, Lap Heng House 50 Gloucester Road	<b>Mexico, 10 D. F. Mexico</b> Ingersoll-Rand S. A. de C. V. Apartado 41-666	<b>Singapore, 22</b> Ingersoll-Rand So. East Asia (Pte) Ltd. G.P.O. Box 2062
<b>Belgium, B-1920 Maelen</b> Ingersoll-Rand Benelux S. A. Industriezone Diegem Kouterveldstraat 10-12	<b>India, Bombay 400025</b> Ingersoll-Rand (India) Ltd. Maybaker House S. K. Ahire Marg P.O. Box 9138	<b>Mid Africa</b> Ingersoll-Rand Co. Ltd. Bowater House, Knightsbridge London, SW1X 7LU England	<b>South Africa, Alberton</b> Ingersoll-Rand Co. S.A. (Proprietary) Ltd. P.O. Box 3720 Airode, 1451
<b>Brazil, Sao Paulo</b> Ingersoll-Rand Ind. e Com. Ltda. Caixa Postal 18824	<b>Ireland, Dublin</b> Ingersoll-Rand Company (Ireland) Ltd. John F. Kennedy Drive Bluebell	<b>Middle East</b> Ingersoll-Rand Middle East Mesogion 2-4 Athens, 610, Greece	<b>Spain, Madrid</b> Cia. Ingersoll-Rand, S.A. Apartado 518
<b>Chile, Santiago</b> Ingersoll-Rand (Chile) Ltda. Casilla 126-D	<b>Italy, Milano</b> Ingersoll-Rand Italiana, S.p.A. Strada Provinciale Cassanese 20060 Vignate, Italy	<b>Netherlands</b> 2380AA Zoeterwoude Ingersoll-Rand Nederland P.O. Box 33	<b>Sweden, Bromma</b> Ingersoll-Rand AB Gardsfogdevagen, 14
<b>Columbia, Bogota</b> Maquinas Ingersoll-Rand de Colombia, S.A. Apartado Aero 7451		<b>Norway, Oslo 1</b> Ingersoll-Rand AB Revierstredet 3 P.O. Box 143-Sentrum	<b>Venezuela, Caracas</b> Ingersoll-Rand de Venezuela S.A. Apartado Postal 70588 Los Ruices
<b>England, London, SW1X 7LU</b> Ingersoll-Rand Co., Ltd. Bowater House, Knightsbridge			

Offices or distributors in principal cities the world over

6-15

**INGERSOLL-RAND.**

Ingersoll-Rand Company  
Woodcliff Lake, NJ 07675