

CP-9A & CP-9F HANDRILS

M & C 746

SECOND EDITION

AUGUST, 1986

Supersedes First Edition March, 1985



WARNING — TO REDUCE RISK OF INJURY,
READ AND UNDERSTAND THIS INSTRUCTION
MANUAL BEFORE OPERATING TOOL.

Instruction and Parts Book for

PNEUMATIC HANDRIL

**CP-9A Model 'N', 'R' & 'X'
CP-9F Model 'K' & 'V'
WITH ROTATION RELEASE
(RIGHT HAND ROTATION)**

**PROTECT YOUR INVESTMENT
IN THE WORLD'S FINEST AIR TOOLS
USE GENUINE CP REPLACEMENT PARTS**

The purchase of replacement parts for your CP tools deserves the same good judgment that resulted in the purchase of the tools themselves. Each genuine CP part is made from carefully selected and inspected material, subjected to sophisticated machinery and finishing processes

and heat-treated to produce just the right combination of hardness, ductility and impact resistance for its intended use. Each part is identical to, and made concurrently with, parts used in production tools. The use of parts other than genuine CP replacement parts can lead to sub-standard performance, early failure, possible damage of other parts and, in some instances, unsafe conditions.



**Chicago
Pneumatic**

Chicago Pneumatic Tool Company - Rock Hill, South Carolina 29730-7463 U.S.A. Telephone : 803-817-7000 FAX :

R139196

GENERAL INSTRUCTIONS

WARNING: "ALWAYS CHECK FOR DAMAGED OR LOOSE HOSES AND FITTINGS BEFORE OPERATION. WHIPPING HOSES CAN CAUSE SERIOUS INJURY."

For satisfactory performance, 80-90 psig (5.6 - 6.2 bar) of clean, dry air is required AT THE TOOL with tool operating. Hose should be 1/2" hose size or larger, used with couplings of a minimum 7/16" I.D. The use of a CA04B360 CHICAGO PNEUMATIC Air Line Separator and Filter and a CA04B362 CHICAGO PNEUMATIC Air Line Pressure Regulator mounted as closely as possible to the tool is recommended.

WARNING: "PROLONGED USE OF VIBRATING TOOLS BY CERTAIN USERS MAY BE HARMFUL TO HANDS AND ARMS."

Air Supply

Daily before using and before putting tool into operation, disconnect air hose and pour a small quantity of recommended oil into tool air inlet. Blow out air line to clear it of accumulated dirt and moisture, connect tool and operate on reduced throttle to allow oil to be carried to valve and cylinder.

CAUTION: Never use higher air pressure to increase the output of the tool. Overloading will drastically shorten the life of all internal parts.

WARNING: "DO NOT MOUNT AIR HOSE QUICK COUPLERS ON THE TOOL. VIBRATION CAN CAUSE BREAKAGE RESULTING IN SERIOUS INJURY FROM WHIPPING AIR HOSES. USE A SHORT LEADER HOSE."

Lubrication

Daily before using and before putting tool into service, pour a small quantity of recommended oil into air inlet. Daily before using and after each four hours of service, remove pipe plug (33) and fill oil reservoir with recommended oil. In addition, use of a C132200 CHICAGO PNEUMATIC Air Line Lubricator installed at the end of each air pipe leading to this pneumatic tool is recommended to assure a constant and adequate supply of lubricant.

Indications of proper lubrication are the presence of an oil mist in the exhaust air and of slight traces of oil on drill or adapter shank. If these are not apparent, check oil reservoir, and make sure port leading from oil chamber to air passage is unobstructed.

Recommended Lubricants

CHICAGO PNEUMATIC Rock Drill Oil is recommended for use with this Handril and may be purchased under the following symbol:

1 pint can -----

If recommended oil is not available, use a good grade SAE #10 rock drill oil.

AIROLENE OILS:

- 1 pt. can -----
- 1 qt. can -----
- 1 gal. can -----
- 5 gal. can -----

The use of synthetic oils is NOT RECOMMENDED due to possible damage to seals, "O" rings, hoses, blades and polycarbonate oiler/filter bowls.

Loss of Power/Erratic Action

Drill failure, loss of power or erratic action may be caused by factors outside the tool. Make the following checks.

1. Check air pressure. For rated performance, 80-90 psig (5.6 - 6.2 bar) air pressure is required AT THE TOOL with tool operating. A drop in air pressure may be caused by lowered compressor output, excessive drain on the air line or by use of hose or connections of improper size or in poor condition.
2. Check for wet or dirty air. Wet air tends to wash lubricant away from cylinder and to rust and corrode the tool. Dirt and foreign matter in the air supply will impede valve action and cause damage to the tool.

If above are in order:

1. Check cylinder and valve lubrication. Disconnect tool and pour a liberal quantity of recommended oil cut with an equal amount of kerosene into tool air inlet. Operate tool on reduced throttle to flush out gum and foreign matter.

CAUTION: When operating tool to flush out gum and foreign matter direct tool exhaust away from operator and co-workers.

2. Check mechanical parts of tool. Disassemble tool, thoroughly clean and inspect all parts. Replace worn or broken parts, relubricate and reassemble tool.

Assembly Cautions

Position Shifter Plunger (82) of Rotation Release Handril in Fronthead (79) BEFORE assembling Chuck Sleeve (78).

Be sure straight spline on piston (61) engages straight spline on chuck sleeve and that spiral spline on piston engages spiral spline of ratchet ring.

Assemble Ratchet Ring (51) in fronthead so that flat of ratchet teeth engage ends of Pawls (49).

If burrs are raised around four ball slots in shank of drill steel, file down smooth to permit easy entry and removal of drill steel and efficient operation of the chuck.

Tighten thru bolts 12-14 lb. ft. torque. After tightening, rotate chuck by hand to make sure rotation is free.

Operating Caution

Drilling into Concealed Electric Line can cause electric shock injury. Make sure the area to be drilled is free of electric lines and conduits.

Maintenance

Do not penalize the operator by requiring him to use a tool which is not in first class condition. A regularly scheduled inspection and repair program will correct minor faults, avoid later, extensive repairs and maintain the tool at its highest efficiency.

1. Keep tool properly lubricated.
2. Provide 80-90 psig (5.6 - 6.2 bar) of clean, dry air AT THE TOOL.
3. Use hose and connections of proper size and in good condition.
4. Set up and maintain a repair and replacement program scheduled at regular intervals.

If rotation release buttons (142) have been removed from muffler, when reassembling ensure buttons are placed in muffler as shown on section A-A on page 2.

When ordering spare parts, give Name, Speed or Size, Model and Serial Number of the tool and Part Number and Description of each part desired.

CROWDER SUPPLY CO., INC. - 8495 ROSLYN ST. - COMMERCE CITY, CO 80022 - TOLL FREE 888-883-5144 - www.crowdersupply.com

CP9A HANDRIL Model "N"
CP9F HANDRIL Model "K"

RIGHT HAND ROTATION

All Threads Are Right Hand Unless Otherwise Specified.

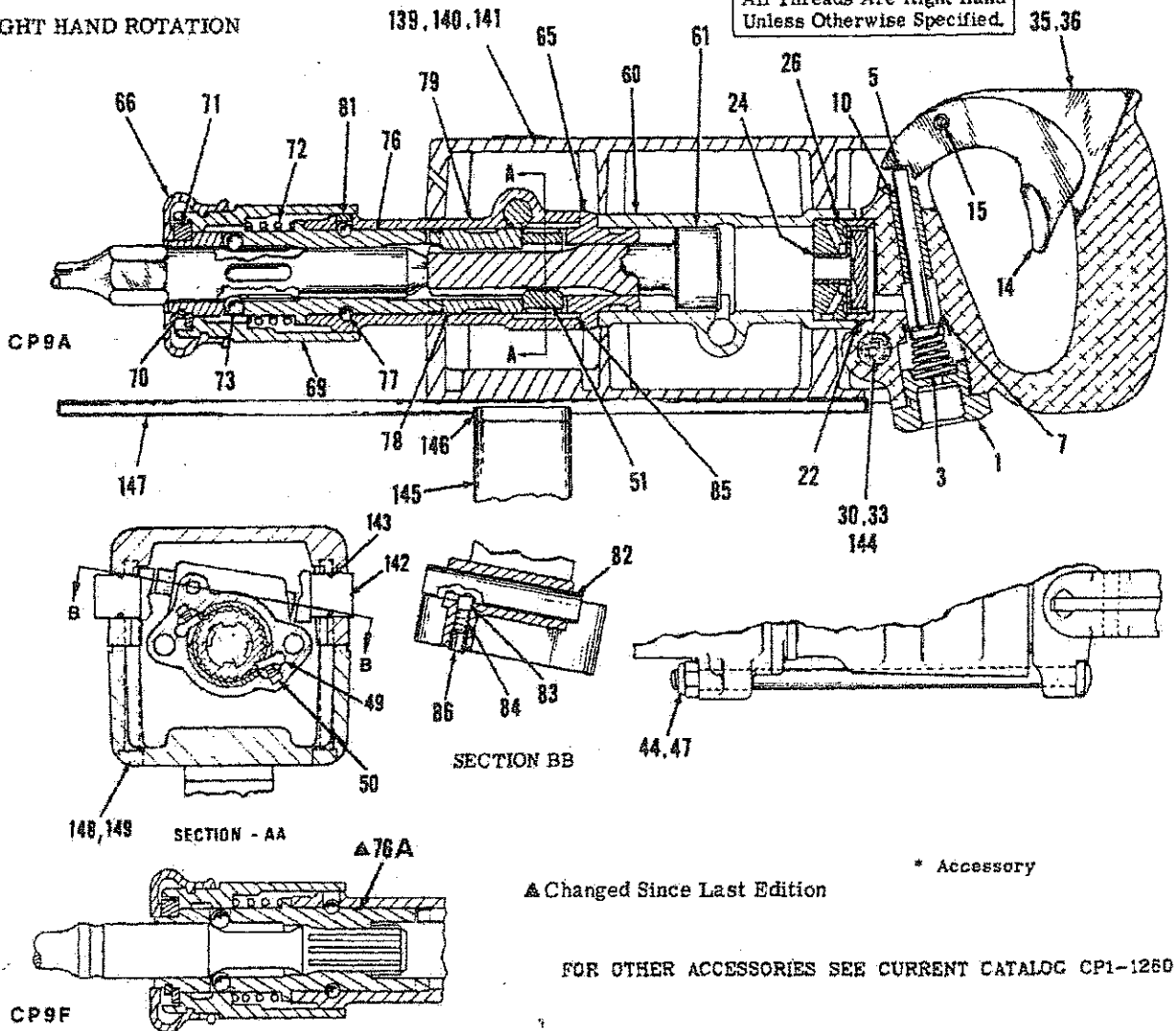

▲ Changed Since Last Edition * Accessory

FOR OTHER ACCESSORIES SEE CURRENT CATALOG CP1-1250

Index No.	CP Part No.	Description	No. Req'd.
1	R085693	Bushing-Air Inlet (3/8")	1
3	R085596	Spring-Throttle Valve	1
5	R086329	Valve-Throttle	1
7	R086098	Seat-Throttle Valve	1
10		Bushing-Throttle Valve Stem	1
14	F027853	Lever-Throttle	1
15	A043627	Pin-Throttle Lever	1
22	R095696	Seat-Rear Valve	1
24	R085887	Valve	1
26	R085698	Seat-Front Valve	1
30	R085695	Felt-Oil Chamber	1
33	C077941	Plug-Pipe (3/8")	1
35	R278018	Handle (incl. Index No's. 7 & 10)	1
36	R278018	Handle Complete (incl. Index No's. 1,3,5,14,15,30,33 & 35)	1
44	F034249	Bolt-Thru	2
47	S013073	Nut-Thru Bolt	2
49	R051355	Pawl	2
50	R085890	Spring-Pawl	2
51	F816123	Ring-Ratchet	1
60	R085886	Cylinder	1
61	F816122	Piston	1
65	R051356	Bushing-Cylinder	1
66	F815343	Excluder-Dust	1
69	Z8375412	Sleeve-Retainer	1
70	F826893	Ring-Retainer	1

Index No.	CP Part No.	Description	No. Req'd.
71	F826863	Plate-Retainer	1
72	R086805	Spring-Sleeve Retainer	1
73	3315 1297 00	Ball-Steel (5/16" Dia.)	4
76	F826892	Chuck(CP9A)	1
76A	*Z8369412	Chuck-Spline(CP9F)	1
77	3315 1294 00	Ball-Chuck Retainer	17
78	R085900	Sleeve-Chuck	1
79	F816120	Fronthead	1
81	F061888	Plug-Ball Retainer	1
82	R051351	Plunger-Shifter	1
83	Z8294412	Plunger-Shifter Detent	1
84	R051353	Spring-Plunger	1
85	Z8264412	Sleeve-Shifter	1
86	C102507	Plug-Pipe (1/16 NPTF)	1
*139	F815350	Muffler Complete (incl. Index No's. 140,145,146 & 147)	1
*140	F815448	Muffler Assy (incl. Index No's. 142,144,148 & 149)	1
*142	F815447	Rotation Release Button Assembly (incl. No 143)	1
*143	C045689	O'Ring (-016)	2
*144	F815446	Muffler Plug Assembly	1
*145	R132714	Dead Handle	1
*146	R132715	Clamping Washer	1
*147	R132716	Depth Gauge	1
*148	R132717	Screw-Cap (1/4"-28 x 2)	6
*149	R132718	Washer	6

When ordering spare parts, give Name, Speed or Size, Model and Serial Number of the tool and Part Number and Description of each part desired.

CROWDER SUPPLY CO., INC. - 8495 ROSLYN ST. - COMMERCE CITY, CO 80022 - TOLL FREE 888-883-5144 - www.crowdersupply.com

Chicago Pneumatic's Worldwide Operations

HEADQUARTERS LOCATION
UNITED STATES
 1800 Overview Drive
 Rock Hill, South Carolina 29730-7463 U.S.A.
 Main Telephone Number: 803-817-7000
 FAX Number:
 Industrial Product Company: 803-817-7237

Australia / New Zealand
 Chicago Pneumatic Tool Company (Aust.) Pty. L
 Unit 27 No. 7, Salisbury Rd., P.O. Box 1195
 Castle Hill NSW 2154 Australia
 FAX 61-2-899-7737 Telephone 61-2-899-7355
 Telex 22189

Belgium
 Chicago Pneumatic Tool Company, S.A.
 Chaussée De Louvain, 510-512
 Leuvensesteenweg, 510-512
 1930 Zaventem Belgium
 FAX 32-2-721-92-97 Telephone 32-2-721-29-40

Canada
 Chicago Pneumatic Tool Company Canada Ltd.
 5895 Kennedy Road
 Mississauga, Ontario, Canada L4Z 2G3
 FAX 416-890-2412 Telephone 416-890-3001

Central America
 Contact Chicago Pneumatic / USA
 for names of CP Authorized Distributors in this area

Germany
 Chicago Pneumatic Tool GmbH
 Hagenauer Straße 57 Postfach 120251
 D-6200 Wiesbaden 12 Germany
 FAX 49-0611-270140 Telephone 49-0611-2701-0
 Telex 4064 134

India
 Chicago Pneumatic India Ltd.
 301/302, L. B. Shastri Marg, P.O. Box 7761
 Mulund, Mumbai 400 080 India
 Fax: 91-22-564-7687 Ph.: 91-22-564-0021
 Telex 1171990 OPT IN

Italy
 Chicago Pneumatic Tool S.p.A.
 Via Bisceglie 9177 - 20152 Milano - Italy
 FAX 39-2-48303034 Telephone 39-2-48302641-2-3
 Telex 313059 CPTMIL I

Mexico
 Chicago Pneumatic Tool de Mexico, S.A.
 Blvd. Puerto Aereo No. 169 Col. Federal
 Mexico, D. F., 15700 Mexico
 FAX 52-5-571-1181 Telephone 52-5-571-3411

South Africa
 Chicago Pneumatic Tool Co. S.A. (Pty.) Ltd.
 20 Anvil Road P.O. Box 105
 Isando, 1600, Transvaal South Africa
 FAX 27-11-974-2324 Telephone 27-11-974-6761
 Telex 745901

South America
 Contact Chicago Pneumatic / USA
 for names of CP Authorized Distributors in this Area

Southeast Asia
 Contact Chicago Pneumatic / USA
 for names of CP Authorized Distributors in this Area

UNITED KINGDOM
 Chicago Pneumatic Construction
 Desoutter Sales Limited
 Eaton Road
 Hemel Hempstead
 Herts HP2 7DR
 England
 Fax +44 (0) 1442 847723/344806
 Tel +44 (0) 1442 847701/344301

UNITED STATES
 (See Headquarters Location)
FOR ALL OTHER LOCATIONS
 Chicago Pneumatic Construction
 Desoutter Sales Limited
 Eaton Road
 Hemel Hempstead
 Herts HP2 7DR
 England
 Fax +44 (0) 1442 847723/344806
 Tel +44 (0) 1442 847701/344301

SPARE PARTS SERVICE CHART

Index No.	CP Part No.	Description	No. Req'd	High Wear 100%	Med. Wear 70%	Low Wear 30%	Non-Wear 10%	Subject To External Damage
1	R085893	Bushing-Air Inlet	1			X		
3	R085596	Spring-Throttle Valve	1			X	X	
5	R086329	Valve-Throttle	1			X		
7	R086098	Seat-Throttle Valve	1		X			
10		Bushing-Throttle Valve Stem	1		X			
14	F027853	Lever-Throttle	1		X			
15	R075404	Pin-Throttle Valve	1		X			
22	R085896	Seat-Rear Valve	1		X			
24	R085897	Valve	1		X			
26	R085898	Seat-Front Valve	1		X			
30	R085895	Felt-Oil Chamber	1				X	
33	C077941	Plug-Pipe	1				L	
35	R278018	Handle	1			X		
44	F034249	Bolt-Thru	2			X		
47	S013073	Nut-Thru Bolt	2		X			
49	R051355	Pawl	2		X			
50	R085890	Spring-Pawl	2			L		
51	F816123	Ring-Ratchet	1		X			
60	R085886	Cylinder	1				X	
61	F816122	Piston	1				X	
65	R051356	Bushing-Cylinder	1				X	
69	Z8375412	Sleeve-Retainer	1				X	
70	F826893	Ring-Retainer	1		X			
71	F826683	Plate-Retainer	1		X			
72	R086605	Spring-Sleeve Retainer	1			X		
73	3315 1297 00	Ball-Steel	4		L			
76	*	Chuck	1					
77	3315 1294 00	Retainer	17	X				
78	R085900	Sleeve-Chuck	1		X			
79	F816120	Fronthead	1			X		
81	F061888	Plug-Ball Retainer	1				L	
82	R051351	Plunger-Shifter	1		X			
83	Z8294412	Plunger-Detent Shifter	1			L		
84	R051353	Spring-Plunger	1			L		
85	Z8294412	Sleeve-Shifter	1		X			
86	C102507	Plug-Detent	1				L	
141	R132710	Muffler	1					X
143	C045689	O'Ring	2				L	
145	R132714	Handle-Dead	1					X
147	R132716	Gauge-Depth	1					X
148	R132717	Screw-Cap	6				L	
149	R132718	Washer	6				L	

* See Parts List

THIS SERVICE CHART IS PUBLISHED AS A GUIDE TO EXPECTANT LIFE OF COMPONENT PARTS. THE REPLACEMENT LEVELS ARE BASED ON AVERAGE TOOL USAGE OVER A ONE YEAR PERIOD

EXAMPLE: For 10 tools in use: 10 high wear items will be required per year, 7 medium wear items, etc.

NOTE: Quantities must be increased where tool is subjected to more severe and/or continuous usage.

LEGEND

X—Type of wear, if no other comments apply.

L—Easily lost Carefully re-serve during disassembly



**Chicago
Pneumatic**

1800 Overview Drive - Rock Hill, South Carolina 29730-7463 U.S.A.