

CP FL25 VR & CP FL25 VRS PICKS

FIRST EDITION
MAY 2002



**WARNING - TO REDUCE RISK OF INJURY,
READ AND UNDERSTAND THIS INSTRUCTION
MANUAL BEFORE OPERATING TOOL.**

Instruction and Parts Book for

PICKS

CP FL25 VR & CP FL25 VRS

**PROTECT YOUR INVESTMENT
IN THE WORLD'S FINEST AIR TOOLS
USE GENUINE CP REPLACEMENT PARTS**

The purchase of replacement parts for your CP tools deserves the same good judgment that resulted in the purchase of the tools themselves. Each genuine CP part is made from carefully selected and inspected material, subjected to sophisticated machinery and finishing processes and heat-treated to produce just the

right combination of hardness, ductility and impact resistance for its intended use. Each part is identical to, and made concurrently with, parts used in production tools. The use of parts other than genuine CP replacement parts can lead to substandard performance, early failure, possible damage of other parts and, in some instances, unsafe conditions.



**Chicago
Pneumatic**

Chicago Pneumatic Tool Company • 1800 Overview Drive • Rock Hill, SC 29730

CP FL25 VR & CP FL25 VRS Picks General Arrangement

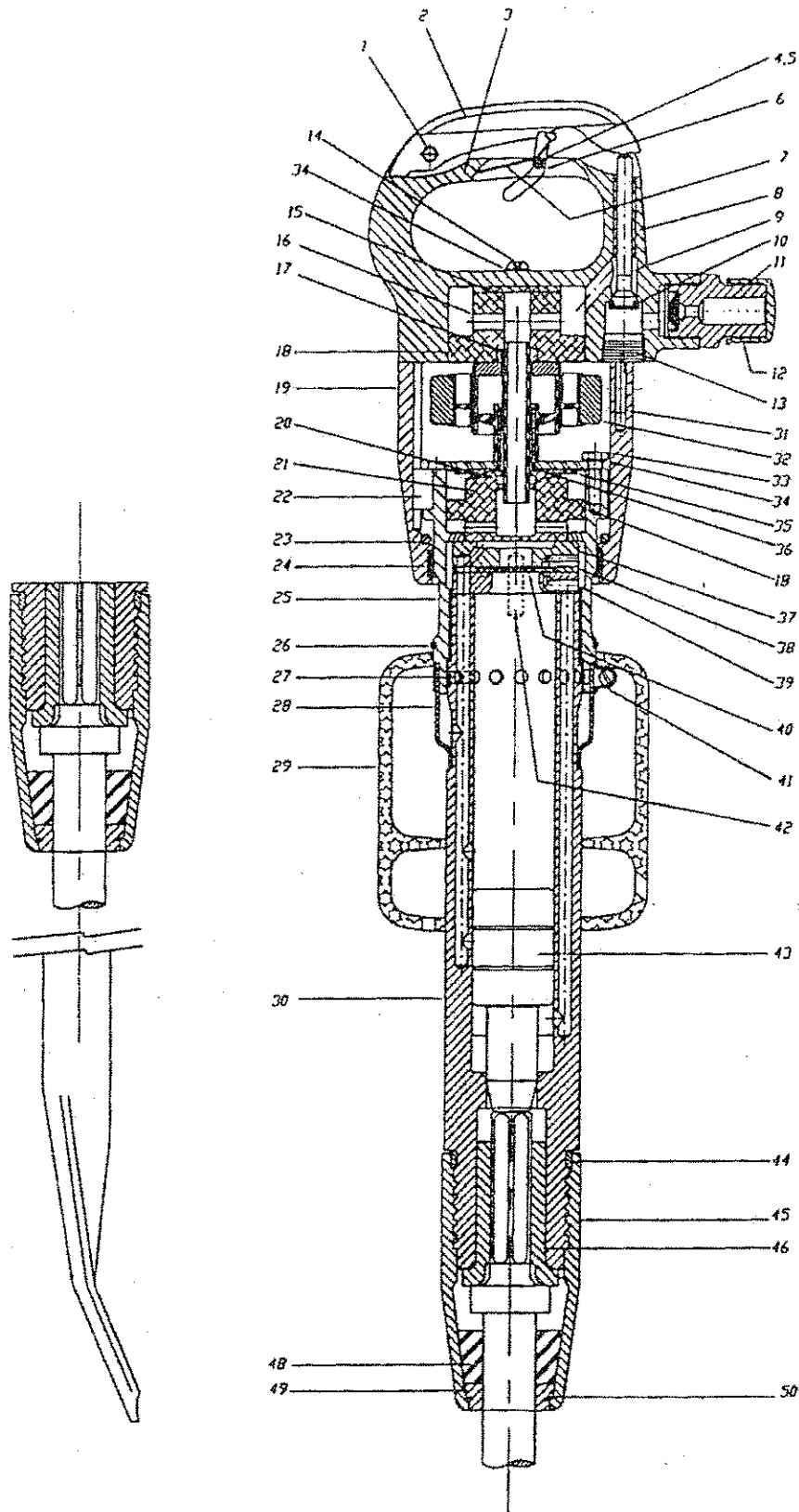

When ordering spare parts, give Name, Speed or Size, Model and Serial Number of the tool and Part Number and Description of each part desired.

Crowder Supply Co, Inc. 8495 Roslyn St Commerce City, CO 80022 (303) 433-5144 FAX: (303) 433-3928 Toll Free: (888) 883-5144 www.crowdersupply.com

CP FL25 VR & CP FL25 VRS Picks Parts List

Index No.	Part No.	Description	No. Reqd.	Index No.	Part No.	Description	No. Reqd.
1	F011472	Throttle Lever Pin	1	29*	F814201	Muffler Complete (Incl.Item No.41	1
2	R157967	Throttle Lever	1			and four screws Part no R140630)	
3	R157965	Handle	1	30	R157127	Cylinder	1
4	R158137	Pin-Lock-off trigger (5/32")	1	31	C064807	Screw - Soc. Hd. 1/4-20 x 1.1/2	6
5	R158138	Pin-Lock-off trigger (3/32")	1	32	P144655	Isolator	1
6	R157968	Lock-off trigger	1	33	P144666	Screw - Flat Hd. 1/4-28 x 5/8	6
7	R157969	Lock-off spring	1	34	KF131560	Washer - Flat	8
8	R156287	T.V. Bush	1	35	P144660	Washer - Spring	1
9	F011476	Throttle valve (incl.Item No.10)	1	36	P144661	Washer - Thrust	1
10	CA088867	O - Ring	1	37	R157128	Upper Valve Case Lid	1
11	F035769	Nipple with gauze	1	38	F012658	Valve Case	1
12	5FPS700	Air inlet nipple cap	1	39	R157129	Lower Valve Case Lid	1
13	C059643	Throttle plug	1	40	R157130	Valve	1
14	R157972	Button head cap screw	2	41*	P052726	Terry Clip	1
15	R157971	P.U. Pad	1	42	F012670	Dowel Pin	2
16	R157970	Handle Spacer	1	43	F011998	Piston	1
17	P144652	Tube - Air	1	44	F035269	Retainer Locking Ring	1
18	C116352	O - Ring	2	45	F035274	Spade Retainer Sleeve	1
19	R157973	Isolator Housing	1	46	F026354	Flanged Sleeve	1
20	H0295840	Seal - Air Tube	1	48	F814522	Rubber Buffer	1
21	R157974	Air Spacer	1	49	P007331	Split Collar (Incl. Item No. 50)	1
22	P144664	Roller - Guide	6	50	P002008	Retainer Ring	1
23	R157977	O - Ring	1				
24	R157976	Ring - Bearing	1			Unique parts for CP FL 25 VR & CP FL 25 VRS Picks	
25	R157975	Adaptor - Cylinder	1	45	F035258	Retainer Sleeve	1
26	R157978	Retaining ring	1	46	F011469	Sleeve	1
27	F001919	Handle Lock Pin	1	48	R157730	Rubber Buffer	1
28	F012747	Exhaust Deflector	1				

ITEMS MARKED THUS * ARE APPLICABLE TO FL 25 VRS ONLY

When ordering spare parts, give Name, Speed or Size, Model and Serial Number of the tool and Part Number and Description of each part desired.

CP FL25 VR & CP FL25 VRS Picks General Instructions

- Air Supply** For maximum efficiency it is essential to operate the tool on a clean, dry supply of compressed air at a recommended pressure of 80 to 90 p.s.i.
- Air piping should be a minimum of 1/2" hose size or larger, used with couplings of a minimum 7/16" I.D. The installation of an air line separator and filter to purify and dry the air supply and a regulator to eliminate any pressure fluctuations are recommended. These control units should be located as near to the tool as operation will allow.
- Operating Cautions** Always operate CP FL25 VR Picks with a steel fitted and with the tool held down to the work, thus avoiding damage which would be caused by allowing the piston to strike against the face at bottom of cylinder bore.
- Never run a tool with a slack cylinder adaptor, if slackness occurs check to see that handle lock pin is in place and undamaged.
- Always wear approved eye protection and safety type shoes to avoid personal injury.
- Preparation for Operation** Prior to the initial operation of the pick, disconnect the air hose and pour approximately one tablespoon of recommended oil into the tool air inlet. Blow out the air line to remove any accumulations of dirt and condensation before connecting to the tool. Connect the air line and operate the tool to allow the oil to be carried through the moving parts of the tool.
- Lubrication** Daily, prior to operating the pick, the "Preparation for Operation" sequence should be carried out. An air line lubricator should be installed in the air line system. This should be one of an adjustable type and regulated to introduce a fine oil spray to the compressed air flow and thus ensure smooth and properly cushioned movement of the piston. This will also reduce stresses in the striking and retaining parts of the tool and so allow for a long working life.
- Daily before using and after each four hours of service fill the oil reservoir with recommended oil. See "Recommended Lubricants".
- Indications of proper lubrication are the presence of an oil mist in the exhaust air and slight traces of oil on the steel shank.
- If these are not apparent, check the lubrication system if necessary, re-adjust the line lubricator.
- Causes of Power or Erratic Action** Tool failures, loss of power or erratic action may be caused by external factors. The following checks should be made:-
1. Check the compressed air pressure - a constant air pressure of 80-90 p.s.i. is required at the tool to maintain the rated performance. A drop in the air pressure may be caused by lowered compressor output, excessive drain on the air line or by using either a hose or connections of improper size and condition or a choked hose pipe or a blocked up air inlet gauze.
 2. Check for impure air - wet air tends to wash lubricant from the cylinder resulting in general rusting and corroding. Dirt in the air supply will impede valve action and cause damage to the tool.
- If these two checks prove negative :-
- 1) Check tool lubrication - disconnect the tool and pour a liberal quantity of recommended oil diluted with an equal amount of paraffin into the tool air inlet. Operate the tool to flush out any condensate or dirt.
 - 2) Check all mechanical parts - disassemble the tool and thoroughly clean and inspect all parts. Replace worn or broken parts, relubricate and reassemble tool.
- Maintenance Recommendations** Economic operation can only be achieved if the Pick is in perfect working condition. A regularly scheduled inspection period programme should be adhered to. The correction of minor faults will prevent extensive repairs at a later date and maintain the tool at its highest efficiency.
1. The pick should be adequately lubricated. Refer to LUBRICATION section.
 2. Provide a constant pressure of 80-90 p.s.i. of clean, dry air to enable the pick to operate efficiently.
 3. The air line system should always be composed of hose and couplings of proper dimension and condition.
 4. Establish and maintain an inspection and repair programme scheduled at frequent, regular intervals.

When ordering spare parts, give Name, Speed or Size, Model and Serial Number of the tool and Part Number and Description of each part desired.

CP FL25 VR & CP FL25 VRS Picks General Instructions

After five or six hours running tighten the cylinder adaptor onto the cylinder as there is a certain amount of yield to new material.

Spare Parts

All replacement and spare parts should be ordered through C.P. Equipment Local Dealers. When requesting these items please state tool name, size, model, letter and serial number in addition to the individual Part Number and Description of Parts.

Disassembly & Assembly Caution

The CP FL25 VR Pick is constructed with precision built components designed to operate at fine clearances and in perfect alignment. Ensure that no parts are scored, burred or distorted during assembly.

Disassembly & Assembly Instructions

To remove the piston, first dismantle handle and isolator housing and remove the isolator. Then remove the exhaust deflector and locking pin and unscrew the cyl. adaptor. The valve complete can now be removed allowing the piston to be withdrawn. Piston and valve parts should be examined for wear and replaced if necessary.

If tool sleeve must be replaced insert a drift in the cylinder, from handle end, and press tool sleeve out.

To extract a sleeve which is too badly worn, to allow the drift to grip, it will be necessary to weld a plug inside the bore for the drift to bear on.

Do not attempt to remove cylinder adaptor without first removing exhaust deflector and handle lock pin. Damaged cylinder adaptor and cylinder will result if these steps are not taken.

Do not attempt to do away with locking device by overtightening the cylinder adaptor on the cylinder. Undue strain on the threaded piston will cause it to break.

Spade & Retainer Assembly

- 1 Place spade retainer sleeve (45) over spade.
- 2 Place split collar (49) over stem of spade, with small end towards blade. Lock split collar together with retaining ring (50).
- 3 Place rubber buffer (48) on shank, forcing it over collar by inserting a screwdriver and rolling buffer over collar.
- 4 Insert shank in cylinder and screw spade retainer sleeve (45) on cylinder until locked in position by retaining locking ring (44).

Safety Recommendations

1. A safety lock-off trigger is provided to prevent the tool from starting if the operator accidentally presses the lever.
2. The operator should keep both feet on the ground and maintain balance at all times.
3. The operator should ensure that his face is never close to the tool.
4. Safety glasses and shoes should be worn.
5. The tool or accessory should never be rested on the operator's toes.
6. The tool should never be started when laying on the ground.
7. The operator should never use his body to control the tool while it is in operation.
8. Both hands of the operator should be kept on the hands of the tool while it is in operation.
9. The lubricant should comply with Chicago Pneumatic's recommendation.
10. When the tool is not in use, remove the accessory unless it is retained in a positive manner.
11. A percussive tool shall not be operated unless the chisel, rivet set or other is in position in the tool and is in contact with the workpiece. Tools shall not be used in such a manner that ejection of an accessory might endanger adjacent personnel.

CP FL25 VR & CP FL25 VRS Picks Recommended Lubricants

Manufacturer	Lubricant
CP	Airolene Tool Oil
Esso	Nuto H 40
Gulf	Harmony 40 AW
Mobiloil	Velocite No. 10
Texaco	Spintex 100
Dalton	P101/P
Shell	Tellus 23
Burmah Castrol	Hyspin AWS 22
BP Power Petroleum	BP Energol CS 40
Duckham	Zeroflo 4
Sternol	Albatross 21
Petrofina	Hydran 31
Chevron	Vistac Oil 9x
Centry Oil	P313

Crowder Supply Co., Inc. 8495 Roslyn St Commerce City, CO 80022 (303) 433-5144 FAX: (303) 433-3928 Toll Free: (888) 883-5144 www.crowdersupply.com



**Chicago
Pneumatic**

Chicago Pneumatic Tool Company (Construction Tools)
1800 Overview Drive, Rock Hill, SC 29730
Web site www.chicagopneumatic.com