

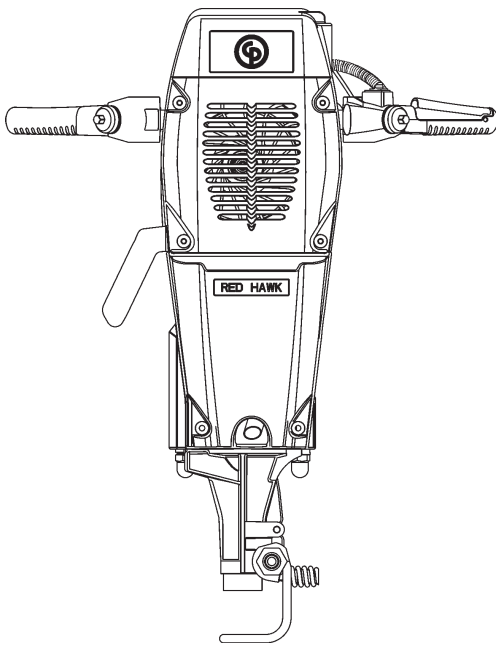

# Safety and operating instructions

**Red Hawk**



[www.cp.com](http://www.cp.com)

 **Chicago  
Pneumatic**



**2006-08**

**No. 9800 0658 93**

© Copyright

STOCKHOLM • SWEDEN



# Contents

<b>SAFETY INSTRUCTIONS</b> .....	5
Safety symbols used .....	5
Machine and tool operating hazards .....	5
Fume and exhaust hazard .....	6
Explosion and fire hazard .....	6
Explosion and fire hazard, continued .....	7
Electrical/Concealed object hazards .....	7
Projectile hazard .....	7
Noise hazard .....	8
Silica/Dust hazard .....	8
Vibration hazard .....	9
Machine modification hazard .....	9
Additional safety instructions .....	10
Protective equipment .....	10
Service and maintenance .....	10
Machine tools .....	10
<b>OPERATING INSTRUCTIONS</b> .....	11
Design and function .....	11
Main parts .....	11
Preparations before starting .....	11
Starting and stopping .....	12
Regular care .....	14
Maintenance .....	15
Trouble shooting .....	16
Scrapping worn-out machines .....	16
Technical data .....	17
Noise and Vibration Declaration Statement .....	17



## Introduction

Thank you for choosing Chicago Pneumatic as a supplier for tools and services.

Chicago Pneumatic is a global company offering a wide range of pneumatic and hydraulic tools that include breakers, rock drills, chipping hammers, clay-diggers, picks and busters, scabblers, pumps and a whole lot more.

In 2001 Chicago Pneumatic Tool Company celebrated 100 years as a pioneer and market-leader in the pneumatic tool industry. Chicago Pneumatic has always focused on providing powerful and reliable products that are easy to maintain and that give good value for money. It's a philosophy that has made us the market-leader for air tools in the USA.

Read more at [www.cp.com](http://www.cp.com)

## About the Safety and operating instructions

The aim of these instructions is to provide you with a full understanding of how to use the pneumatic breaker in an efficient, safe way. The instructions also give you advice and tell you how to perform regular maintenance on the pneumatic breaker.

Before using the pneumatic breaker for the first time you must read these instructions carefully and understand all of them.



## SAFETY INSTRUCTIONS



To reduce the risk of serious injury or death to yourself or others, read these safety instructions before operating the machine.

Post these safety instructions at work locations, provide copies to employees, and make sure that everyone reads the safety instructions before operating or servicing the machine.

Comply with all safety regulations.

### Safety symbols used

The indications **Danger**, **Warning** and **Caution** have the following meanings:

 <b>Danger</b>	<b>Indicates an imminently hazardous situation which, if not avoided, will result in death or serious injury.</b>
 <b>Warning</b>	<b>Indicates a potentially hazardous situation which, if not avoided, could result in death or serious injury.</b>
 <b>Caution</b>	<b>Indicates a potentially hazardous situation which, if not avoided, may result in minor or moderate injury.</b>

### Machine and tool operating hazards

#### **Warning**

Sudden or unexpected movement of the machine may occur during operation, which may cause injuries. In addition losing your balance or slipping may cause injury. To reduce such risks:

- › Make sure that you always keep a stable position with your feet as wide apart as your shoulder width, and keep a balanced body weight.
- › Stand firmly and always hold on to the machine with both hands.
- › Do not start the machine when it is laying on the ground.
- › Make sure that the handles are clean and free of grease and oil.

#### **Warning**

Unintended start of the machine may cause injury.

- › Keep your hands away from the start and stop device until you are about to start work.

#### **Warning**

The working tool is exposed to heavy strains when the machine is used and after a certain amount of use the tool may break due to fatigue. If the tool breaks, there may be sudden or strong movements. Such sudden or strong movements may cause serious injury.

- › Make sure that you always keep a stable position with your feet as wide apart as your shoulder width, and keep a balanced body weight.
- › Keep your feet away from the working tool.
- › Do not 'ride' on the machine with one leg over the handle, since you could be seriously injured if the tool suddenly were to break.
- › Check regularly for any wear on the working tool, and if there are any risks for damage or fractures.
- › Do not use worn out or damaged working tools.

#### **Warning**

An incorrect dimension of the working tool's shank can result in the working tool being dropped or ejected. A dropped or ejected working tool can cause personal injury.

- › Before the working tool is mounted, make sure that the shank is correct for the machine.
- › An working tool without a collar should not be used.

#### **Warning**

If the working tool retainer on the machine is not in a locked position, the tool can be ejected with great force, which can cause serious injury.

- › After the working tool is mounted and locked, the lock function must be checked by pulling the working tool sharply downwards.
- › Make sure that the tool is fully inserted and the tool retainer is in a locked position before the machine is started.



### **⚠ Warning**

Changing the inserted tool while the machine is running may cause serious injury.

- › Before changing the working tool, always stop the machine and close down the machine by pushing the start and stop device.

### **⚠ Warning**

The exhaust pipe and the bottom of the machine can become very hot during operation, and can remain hot during a period of time after the machine has been shut off.

- › To reduce the risk of burns or related injuries, avoid contact with the exhaust pipe or the bottom of the machine.

## **Fume and exhaust hazard**

---

### **⚠ Danger**

The exhaust fumes from the machine's combustion engine contain carbon monoxide which is poisonous. Inhalation of exhaust fumes can cause serious injury or death.

- › Do not inhale exhaust fumes.
- › Never operate the machine indoors or in poorly ventilated areas.

## **Explosion and fire hazard**

---

### **⚠ Danger**

If the machine comes in contact with explosives, an explosion may occur. Explosions may cause serious injury or death.

To reduce such risks of explosion:

- › Never operate the equipment near any explosives, including dynamite or other explosives in the rock.
- › Make sure that there are no explosives in the rock.
- › Never break or drill in an old hole.

### **⚠ Warning**

Breaking and working with certain materials can cause sparks, which may ignite explosive gases which can cause explosions. Explosions may cause serious injury or death.

To reduce such risks of explosion:

- › Never operate the equipment in any explosive environment.
- › Do not use the machine near flammable materials, fumes or dust.
- › Make sure that there are no undetected sources of gas.

### **⚠ Warning**

During operation of the machine, the exhaust pipe gets very hot and may stay hot for a period of time even after you have shut off the engine. Materials that come into contact with a hot exhaust pipe may ignite and cause a fire or an explosion, which can cause serious injury. To reduce such risks of fire or explosion:

- › Do not use the machine near flammable materials, fumes or dust. During breaks in work, remember not to place the machine near flammable materials.
- › Do not operate the machine in explosive environments.
- › Keep the workplace clean and free from foreign objects.



## Explosion and fire hazard, continued

---

### **Warning**

Fuel is highly flammable, and it's vapors can explode if ignited, which can cause serious injury or death. To reduce such risks of fire or explosion:

- › Store fuel only in containers that are specifically designed and approved for storage of fuel. Empty fuel containers must be properly taken care of and sent back to the retailer.
- › Operate the machine with the fuel cap securely in place. Never remove the fuel cap or add fuel when the engine is hot. Stop the engine and allow it to cool before adding fuel. When opening the fuel cap, always loosen the cap slowly to relieve any pressure in the tank. Do not overfill the tank.
- › Always mix and add fuel in a clean and well-ventilated area. Make sure that this outdoor area is free from any flames or sparks. Never smoke while fuelling, mixing fuel, operating or servicing the machine. Avoid spilling fuel. Wipe up any fuel that is spilled on the machine. Fill the tank at least ten meters (30 feet) away from where you intend to use the machine.
- › Do not use a machine that is leaking fuel. Check regularly for any leakage.
- › To minimize the risk of fuel leakage during transportation, ensure that the machine is in an upright position during transportation.
- › Do not use the machine near flammable materials, fumes or dust. During breaks in work, do not place the machine near flammable materials.
- › Do not operate the machine near any materials that create sparks. Remove all hot objects and objects that create sparks prior to using machine.
- › Do not operate the machine in an explosive environment.
- › Protect your skin from contact with fuel.

## Electrical/Concealed object hazards

---

### **Warning**

The machine is not electrically insulated. If the machine comes in contact with electricity, serious injuries or death may result.

- › To reduce the risk of injury or death, never break near any electric wiring or other source of electricity.
- › Make sure that there are no concealed wires or other sources of electricity.

### **Warning**

During breaking or hammering, concealed wires and pipes constitute a danger that can result in serious injury.

- › Before you start breaking, check the composition of the material you are to work on.
- › Watch out for concealed electrical wiring, water, sewage and gas pipes and phone lines.
- › If the tool seems to have hit a concealed object, immediately switch off the machine.
- › Make sure that there is no danger before continuing.

## Projectile hazard

---

### **Warning**

During breaking or hammering, splinters or other particles of rock may become projectiles and cause bodily injury by striking the operator or other persons.

- › Use approved personal protective equipment, including impact resistant safety glasses with side protection, to reduce the risk of being injured by a projectile.



## Noise hazard

---

### Warning

High sound levels may cause permanent hearing loss.

- › Use hearing protection in accordance with occupational health and safety regulations.

## Silica/Dust hazard

---

### Warning

Exposure to crystalline silica (sometimes called “silica dust”) as a result of breaking, drilling, or hammering of rock, concrete, asphalt or other materials may cause silicosis (a serious lung disease), silicosis-related illnesses, cancer, or death. Silica is a major component of rock, sand and mineral ores.

To reduce silica exposure:

- › Use proper engineering controls to reduce the amount of silica in the air and the build-up of dust on equipment and surfaces. Examples of such controls include: exhaust ventilation and dust collection systems, water sprays, and wet drilling. Make sure that controls are properly installed and maintained.
- › Wear, maintain, and correctly use approved particulate respirators when engineering controls alone are not adequate to reduce exposure below permissible levels.
- › Participate in air monitoring, medical exams, and training programs offered by your employer and when required by law.
- › Wear washable or disposable protective clothes at the worksite; shower and change into clean clothes before leaving the worksite to reduce exposure of silica to yourself, other persons, cars, homes, and other areas.
- › Do not eat, drink, or use tobacco products in areas where there is dust containing crystalline silica.
- › Wash your hands and face before eating, drinking, or using tobacco products outside of the exposure area.
- › Work with your employer to reduce silica exposure at your worksite.

### Warning

Some dust or other airborne material created during use of the machine may contain chemicals known to the State of California to cause cancer and birth defects or other reproductive harm. Some examples of such chemicals are:

- › Crystalline silica and cement and other masonry products.
- › Arsenic and chromium from chemically-treated rubber.
- › Lead from lead-based paints.

To reduce your exposure to these chemicals, work in a well ventilated area, and work with approved safety equipment, such as dust masks that are specially designed to filter out microscopic particles.



## Vibration hazard

---

### Warning

Normal and proper use of the machine exposes the operator to vibration. Regular and frequent exposure to vibration may cause, contribute to, or aggravate injury or disorders to the operator's fingers, hands, wrists, arms, shoulders and/or other body parts, including debilitating and/or permanent injuries or disorders that may develop gradually over periods of weeks, months, or years. Such injury or disorder may include damage to the blood circulatory system, damage to the nervous system, damage to joints, and possibly damage to other body structures.

If numbness, tingling, pain, clumsiness, weakened grip, whitening of the skin, or other symptoms occur at any time, when operating the machine or when not operating the machine, do not resume operating the machine and seek medical attention. Continued use of the machine after the occurrence of any such symptom may increase the risk of symptoms becoming more severe and/or permanent.

The following may help to reduce exposure to vibration for the operator:

- › Let the tool do the job. Use a minimum hand grip consistent with proper control and safe operation.
- › When the percussion mechanism is activated, the only body contact with the machine you should have is your hands on the handles. Avoid any other contact, e.g. supporting any part of the body against the machine or leaning onto the machine trying to increase the feed force. It is also important not to keep the trigger engaged while extracting the tool from the broken work surface.
- › Make sure that the inserted tool is well-maintained (including sharpness, if a cutting tool), not worn out, and of the proper size. Working tools that are not well-maintained, or that are worn out, or that are not of the proper size result in longer time to complete a task (and a longer period of exposure to vibration) and may result in or contribute to higher levels of vibration exposure.
- › Stop working immediately if the machine suddenly starts to vibrate strongly. Before resuming the work, find and remove the cause of the increased vibrations.

- › Do not grab, hold or touch the inserted tool when using the machine.
- › Participate in health surveillance or monitoring, medical exams, and training programs offered by your employer and when required by law.

**Note!** See the "Noise & Vibration Declaration Statement" for the machine, including the declared vibration values and "Additional Vibration Information". These can be found at the end of the Safety and Operating instructions.

## Machine modification hazard

---

### Warning

Any machine modification not approved by Chicago Pneumatic may result in serious injuries to yourself or others.

- › The machine must not be modified without Chicago Pneumatic's permission.
- › Use only original parts and accessories approved by Chicago Pneumatic.



## Additional safety instructions

---

- › Machines and accessories must only be used for their intended purpose.
- › Only qualified and trained persons may operate or maintain the machine.
- › Keep your hand away from the start and stop device until work is to begin.
- › Learn how the machine is switched off in the event of an emergency.
- › The machine should be operated at reduced power when drilling is started.
- › Release the start and stop device in case of interruption of the energy supply.
- › Always inspect the equipment prior to use. Do not use equipment if you suspect that it could be damaged.
- › Check the working tools for wear or damage at regular intervals. Do not use worn out or damaged working tools.
- › Always use your common sense and good judgment.
- › Do not use the machine when you are tired or under the influence of drugs, alcohol or anything else that may affect your vision, reactions or judgement.
- › Participate in safety and training courses.
- › Never strike or abuse any equipment.
- › Keep the machine and tools in a safe and locked place out of the reach of children.
- › Make sure that the all attached and related equipment is properly maintained.
- › Signs and stickers that are important for your safety and the care of the machine are included with every machine. New signs and stickers can be ordered using the spare parts list.

## Protective equipment

---

Always use approved personal protective equipment. Operators and other persons in the work area must wear protective equipment, including at a minimum:

- › Protective helmet
- › Hearing protection

- › Impact resistant eye protection with side protection
- › Respiratory protection when appropriate
- › Protective gloves
- › Protective boots

## Service and maintenance

---

Regular maintenance is a prerequisite for keeping the machine a safe tool. Carefully follow the operating instructions.

- › Use only authorized parts. Any damage or malfunction caused by the use of unauthorized parts is not covered by Warranty or Product Liability.
- › Change damaged parts immediately.
- › Replace worn out components in good time.
- › For major service to the machine, contact your nearest authorized Chicago Pneumatic workshop.
- › When cleaning mechanical parts with solvent, make sure that current health and safety regulations are complied with and that ventilation is satisfactory.

## Machine tools

---

- › Keep the tools clean and in a good condition. Check tools regularly and make sure that they are sharp.



# OPERATING INSTRUCTIONS

## Design and function

Red Hawk is a hammering machine. It is intended to be used for breaking asphalt and concrete.

## Main parts

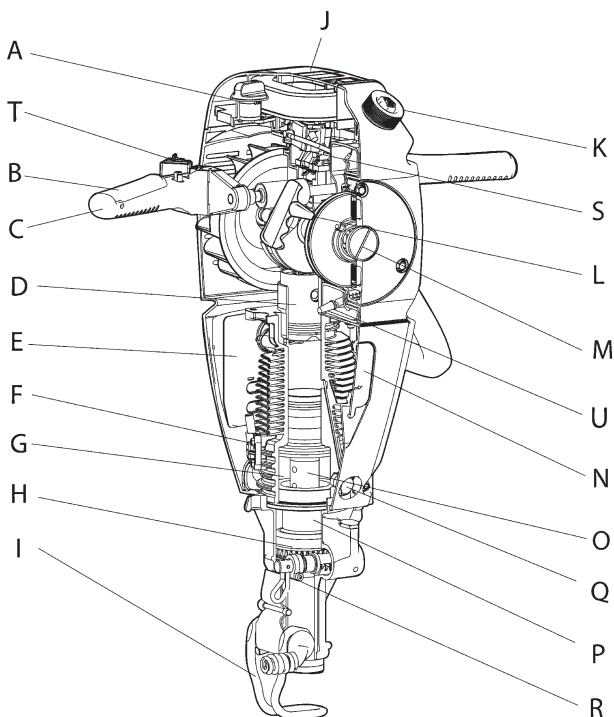

- A Choke
- B Throttle lever
- C Vibration-dampening handle
- D Engine piston
- E Silencer
- F Intake valve for flushing air
- G Compression chamber for flushing air
- H Rotation mechanism
- I Tool retainer
- J Air filter cover
- K Tank cap
- L Starting handle
- M Power take-off (PTO)
- N Spark plug cover
- O Percussion piston
- P Gas duct

- Q Gas duct valve
- R Function selector (Red Hawk)
- S Venturi
- T Stop-button
- U Fuel filter

## Preparations before starting

### Tool shank

#### **⚠ Warning**

An incorrect dimension of the working tool's shank can result in that the working tool may be dropped or ejected. A dropped or ejected working tool can cause personal injury.

- › Before the working tool is mounted, make sure that the shank is correct for the machine.
- › An working tool without a collar should not be used.

#### **⚠ Warning**

If the working tool retainer on the machine is not in a locked position, the tool can be ejected with great force, which can cause serious injury.

- › After the working tool is mounted and locked, the lock function must be checked by pulling the working tool sharply downwards.
- › Make sure that the tool is fully inserted and the tool retainer is in a locked position before the machine is started.

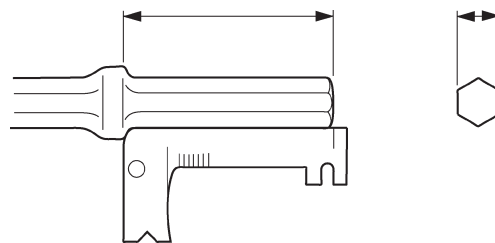

Use a shank gauge to check that the tool shank is of the correct size, i.e. 7/8" x 4 1/4" (H 22x108 mm). The shank must be clean and the tool must be in good condition.



### Fuel

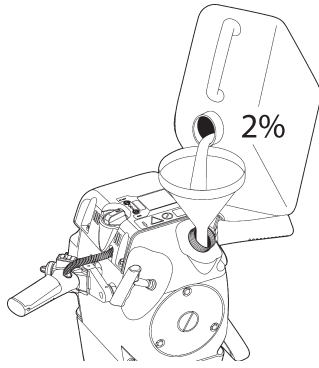

Red Hawk uses a mixture of gasoline and two-stroke oil, 1 part oil to 50 parts gasoline (2%).

### Two-stroke oil

Use a high-quality two-stroke oil for air-cooled two-stroke motors (not two-stroke oil for outboard motors). Contact your nearest Chicago Pneumatic representative for advice on the correct two-stroke oil.

## Starting and stopping

### ⚠ Warning

Unintended start of the machine may cause injury.

- › Keep your hands away from the start and stop device until you are about to start work.

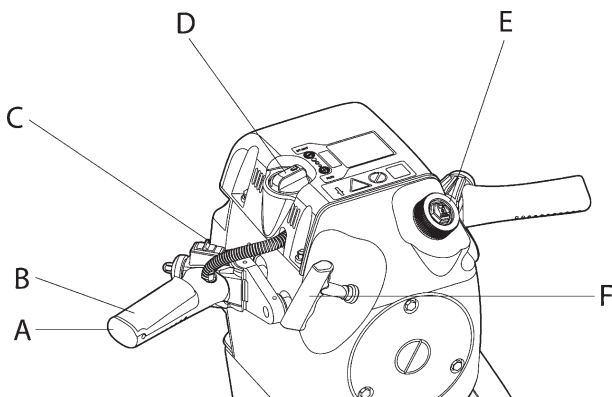

- A Vibration-dampening handle
- B Throttle lever
- C Stop button
- D Choke
- E Fuel filler
- F Starting handle

### Cold start

1. Close the choke (turn the choke control counter clockwise).

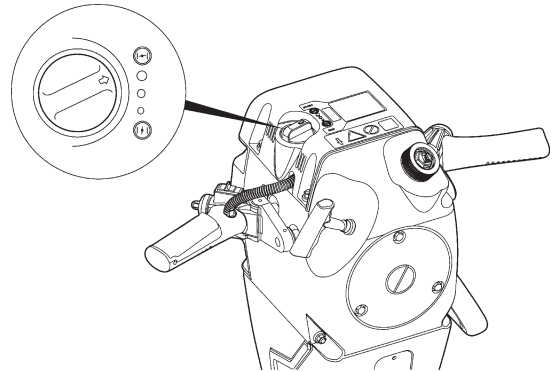

2. Push the throttle lever down and pull the starter handle.

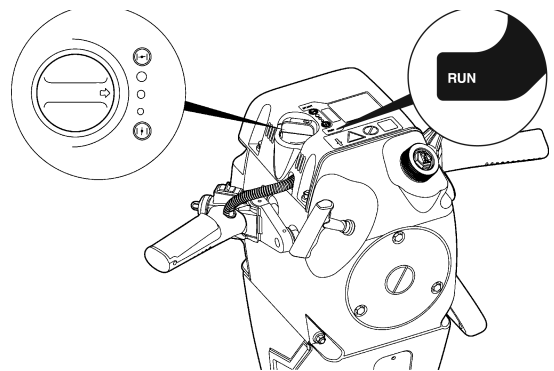



- When the machine starts, slowly turn the choke clockwise towards position (RUN) during a 2–3 minutes warm-up period.

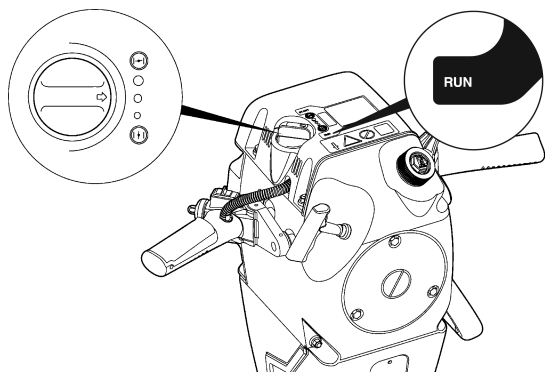

### Restarting a warm machine

- Check that the choke is open (i.e. knob in position RUN).
- Pull the starter handle.

If the machine stops after a short while, or does not start at all, follow the procedure for cold starting.

If the machine does not start, it may have been flooded (i.e. too much fuel in the combustion chamber).

Open the choke (RUN position) and try starting the engine again.

If the machine still does not start, see the section entitled "Trouble shooting".

### Number of revs

The engine speed is regulated by means of the throttle lever:

Lever released – idling speed

Lever depressed – full engine speed

### Ground probing

If the machine is started on top of long tools such as probing rods, a starter-cord bracket must be used to prevent the cord from damaging the fuel tank.

### Stopping the engine

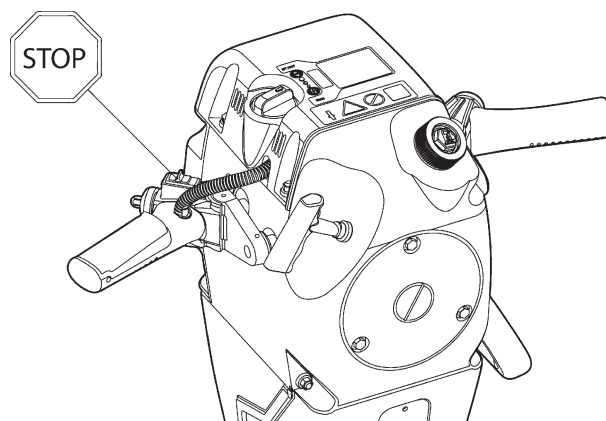

Stop the engine by depressing the stop button.

Drain the fuel tank before transporting the machine, also drain the fuel tank when the machine is not to be used for a long period of time.

## Regular care

### Air filter

In the event of continuous use, check and change the filter at least every shift.

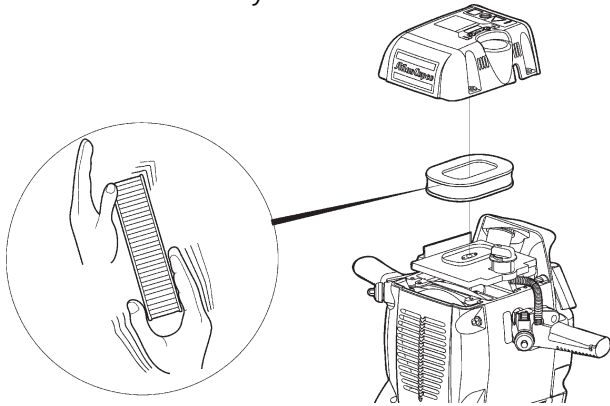

1. Unscrew the filter cover.
2. Carefully strike the filter against the palm of your hand. Extremely dirty filters must be replaced. The filter must never be washed.

### Gas duct

The gas duct must be checked regularly for carbon deposits, and cleaned if necessary.

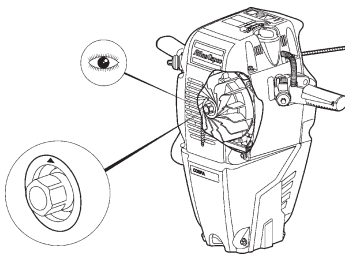

1. Pull the starting handle until the arrow in the centre of the flywheel (which can be seen through the fan cover) points upwards. This indicates that the engine piston is in the upper position.

2.

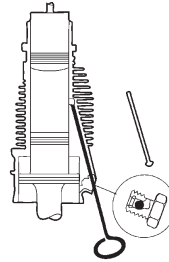

Unscrew the gas duct valve and take out the cleaning rod. Clean the duct and cleaning rod using the cleaning needle provided.

3. Clean the cleaning thread.
4. Clean the channel using the cleaning needle provided.
5. Check that the ball in the gas duct valve is not stuck.

### Decals

Replace damaged or worn decals. Order numbers can be found in the spare parts list.

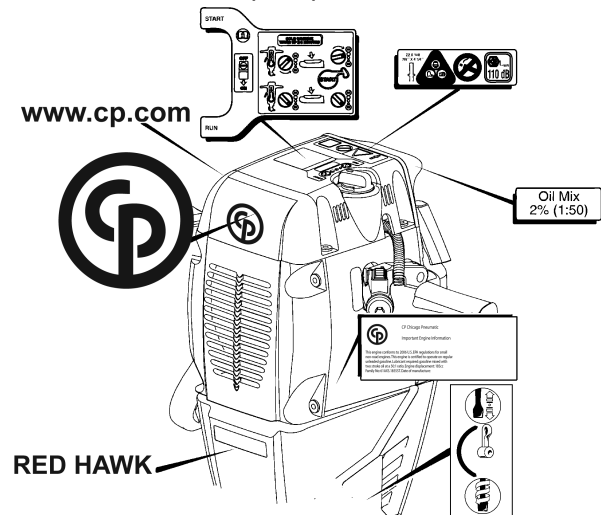



## Maintenance

### Spark plug

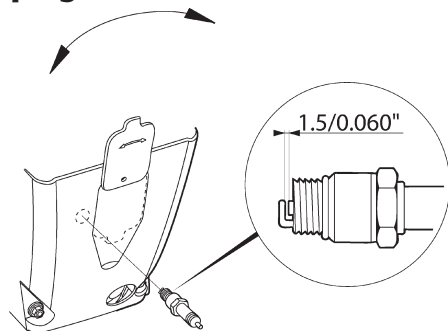

1. Lift the spark plug cover by the lower lip, and turn it up to one side.
2. Use a plug spanner to remove the spark plug.
3. If the spark plug is dirty or burned, it must be replaced. Use original Bosch WR7AC spark plugs.
4. If the pin has been dampened by fuel, dry it off, check the ignition spark, and pull the starter handle 2–3 times to ventilate off any excess fuel.
5. Fit the spark plug back into the cylinder.

**Note!** The electrode gap should be 0.060 in. (1.5 mm).

### Changing the starting cord

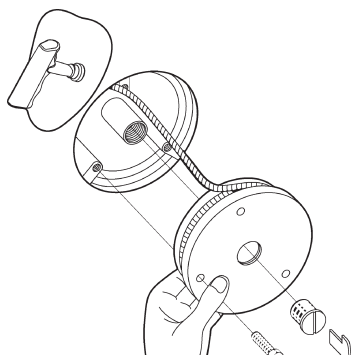

1. Remove the PTO screw-cap (See image under "Main parts"). Remove the three bolts from the protective cover of the starting mechanism.

2. Lift off the cover, grasping the starter pulley as well. Let the cover rotate carefully against the starter pulley, to release the spring tension.
3. Remove the old starting cord.

### Fitting a new cord

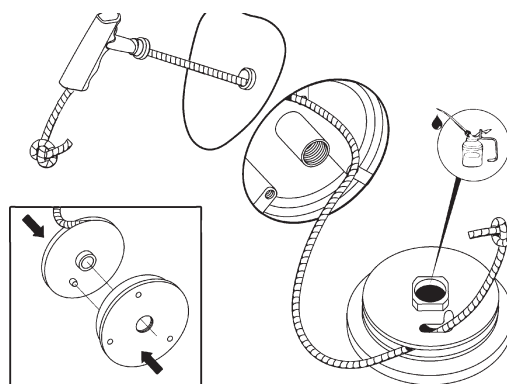

1. Oil the needle bearing in the starter pulley.
2. Fit together the starter pulley and protective cover, so that the starting spring locates in the starter pulley.
3. Wind the full length of the cord onto the pulley.
4. Pre-tension the starting spring by about one turn (clockwise) before fitting the assembly into place.
5. Pull the starting handle carefully, in order to locate the cover correctly.
6. Fit and tighten the hexagonal bolts and the PTO screw-cap.

## Tool chuck

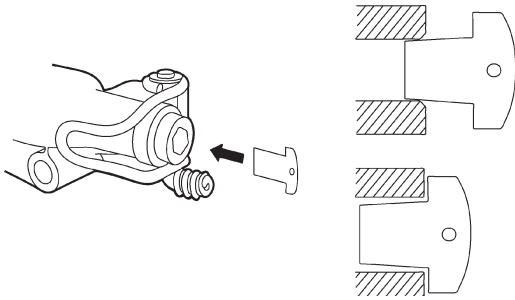

If the chuck gauge provided can be inserted fully across the flats of the hexagonal chuck, this indicates that the chuck is worn out and must be replaced.

## Carburettor

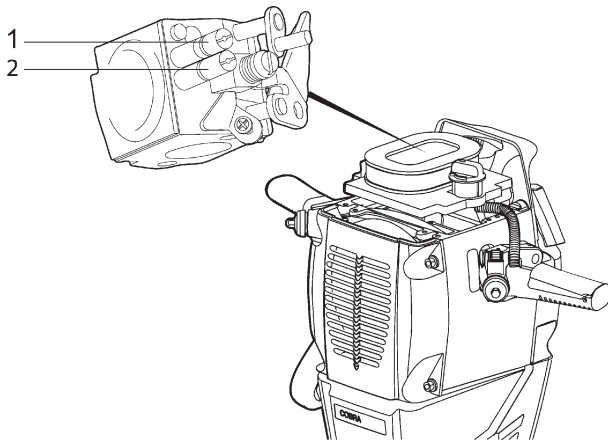

On delivery the carburettor is adjusted and locked so it meets EPA's exhaust-gas standard.

The carburettor nozzle does not normally need to be adjusted.

Normal setting:

Main nozzle (1) ..... 2.0 turns open

Idling nozzle (2) ..... 2.0 turns open

When loaded, the maximum revs should be 2500–2650 rpm. The idling revs should be 1600–1800 rpm.

## Trouble shooting

If the engine does not start, is difficult to start, runs unevenly or has poor output, check the points mentioned below (See image under "Main parts").

1. Check that the Stop button (See C under "Starting and stopping") is in the ON position.
2. Check the fuel level.
3. Check the spark plug's electrode gap.
4. Check that the air filter is not blocked.
5. Check that the fuel filter (See U under "Main parts") is not blocked.

If the machine still does not work satisfactorily following this procedure, please contact your nearest authorized Chicago Pneumatic workshop.

## Scrapping worn-out machines

Worn-out machines must be dealt with and deposited in such a way that the maximum amount of material can be recycled and the environment is affected as little as possible.

**Note:** Before a motor-driven breaker is deposited or thrown-away it must be emptied and cleaned of petrol. Remaining petrol must be dealt with in a way that does not affect the environment.



## Technical data

<b>Red Hawk</b>	
<b>Engine</b>	
Type	1 cylinder, two-stroke, air cooled
Cylinder displacement	11.3 ci (185 cc)
Speed, crankshaft (rpm)	Full speed 2500–2650 rpm Idling 1600–1800 rpm
Carburettor	Membran type (Walbro)
Ignition system	Thyristor type, breakerless
Spark plug (recommended)	Bosch WR7AC
Spark plug gap	0.060 in (1.5 mm)
Starter	Magnapull
Fuel type	Gasoline 90–100 octane, unleaded only
Oil type	Use a high-quality two-stroke oil for air-cooled two-stroke motors (not two-stroke oil for outboard motors)
Fuel mixture	2% (1:50)
Fuel consumption	Approx. 0.29–0.37 US gallons/hour (1.1–1.4 litres/hour)
<b>Other data</b>	
Tool shank	H 7/8 x 4 1/4 in. (22x108 mm)
Machine weight	51.6 lb (23.4 kg)
Service weight (machine incl. fuel and tools)	56.4 lb (25.6 kg)
Length	27 1/3 in. (694 mm)
Width, max	18 1/2 in. (470 mm)

## Noise and Vibration Declaration Statement

### Sound effect according to EN ISO 3744 in accordance with directive 2000/14/EG

Lp measured, r = 1 m dB (A) rel 20 µPa	105
Lw guaranteed dB (A) rel 20 µPa	107

### Vibration according to EN28662-5

Measured vibration value (a m/s <sup>2</sup> )	5.0
Spread in method and production (ka m/s <sup>2</sup> )	3.5

*These declared values were obtained by laboratory type testing in compliance with the stated standards and are not adequate for use in risk assessments. Values measured in individual work places may be higher than the declared values. The actual exposure values and risk of harm experienced by an individual user are unique and depend upon the way the user works, the workpiece and work station design, as well as upon the exposure time and the physical condition of the user. We, Chicago Pneumatic, cannot be held liable for the consequences of using the declared values, instead of values reflecting the actual exposure, in an individual risk assessment in a work place situation over which we have no control.*







**2006-08**

**No. 9800 0658 93**

© Copyright

STOCKHOLM • SWEDEN

