

# Hydraulic Rock and Concrete Splitters

## Application Notes

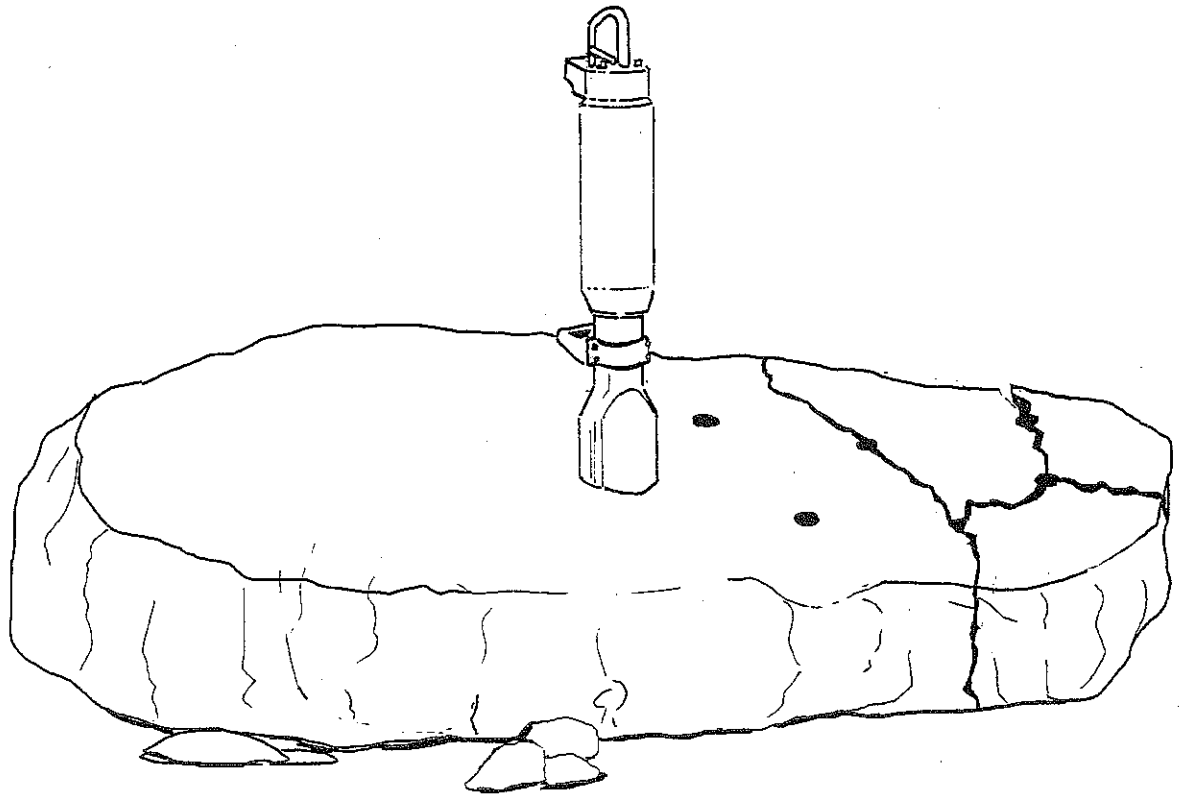

englisch

**darda**<sup>®</sup>

# Contents

1. Introduction	2
2. How a splitter works	3
2.1 Rule of thumb	3
2.2 The wedge principle	3
3. Work preparations	4
4. Drilling	5
4.1 Drilling machines	5
4.2 Requisite drill-hole diameter	5
4.3 Requisite drill-hole depth	6
4.4 Requisite drill-hole dimensions	6
4.5 Drill-hole straightness	6
4.6 Requisite drill-hole position	7
5. The splitting process	8
5.1 Using the splitter	8
5.2 Determining the direction of the split	9
5.3 Splitting with multiple splitting cylinders	9
5.4 Long, straight split with multiple splitting cylinders	10
5.5 Splitting wedged blocks	10
5.6 Splitting with pressure shells	11
6. Enlarging a split	11
6.1 Installing enlarging counter wedges	11
6.2 Enlarging with enlarging counter wedges	12
6.3 Enlarging splits and cutting reinforcing rods with HCS 5 C combi-shears	12
6.4 Enlarging with enlarging feathers	13
7. Routine maintenance	14
7.1 Lubricating the wedge set	14
7.2 Checking the hydraulic fluid level	14
8. Demolishing solid and reinforced concrete	15
8.1 Concrete walls and panels	15
8.2 Very thin concrete walls	15
8.3 Partial demolition	16
8.4 Making an opening in a concrete wall (combined use of diamond-tipped saw and splitter)	16
8.5 Capping off concrete piles	17
8.6 Concrete blocks with extensive reinforcement	18
9. Demolishing rock and natural stone	18
9.1 Rock excavation	18
9.2 Splitting stratified rock	19
9.3 Splitting freestanding boulders	19
9.4 Splitting rock below ground level	20
9.5 Tunnel enlargement	21
9.6 Pipe jacking	21
10. Production of natural stone blocks	22

# 1. Introduction

*Man has always used the forces of nature to disintegrate rocks or reduce them in size. Typically, he would drill a hole in the rock, fill it with water and let it freeze, causing the rock to split. Alternatively, he would drive in wooden wedges and saturate them with water, causing them to swell and split the rock.*

*Even today, these age-old methods are still used in quarries in many countries throughout the world. They no longer conform, however, to modern demands for economical working practices, increased productivity, the use of automation and improvements in working conditions. The discovery of explosives and, much later, the development of pneumatic demolition machines represented a considerable advance in this field. However, the costs entailed by these methods have risen steeply in recent decades while the use of explosives is very often prohibited entirely.*

*The invention of hydraulic demolition machines brought further progress. The use of hydraulic power, combined with new ideas and materials, made it possible to improve cost efficiency and working methods. Darda rock and concrete splitters, developed in 1962, introduced a demolition technique of exceptional efficiency and versatility.*

*The following pages contain a description of how hydraulic splitters work and instructions for their correct use, enabling the operator to utilise their capabilities to the utmost effect in the minimum of time.*

## 2. How a splitter works

### 2.1 Rule of thumb

*The resistance of concrete and rock to a force applied internally is only about 10% of their resistance to a force applied externally.*

*In other words, concrete and rock can hold out against extreme pressures, applied from outside, without being affected. By comparison, their resistance to a force applied internally is relatively low, with the result that they disintegrate easily. This rule of thumb was the decisive factor in the development of hydraulic stone and concrete splitters and their method of operation, based on the wedge principle.*

### 2.2 The wedge principle

*The wedge principle has long been known, but in former times its application involved driving wooden or metal wedges into the rock with a heavy hammer - arduous, tiring and extremely time-consuming work. DARDA mechanised this process with its hydraulic rock and concrete splitters, with the result that the wedge principle can now be put to use quickly, simply and, above all, to the utmost effect.*

*The wedge set for the splitting cylinder consists of a wedge, located between two counter wedges. The set is inserted into a drill-hole of a precise depth and diameter. Hydraulic pressure drives the wedge forward between the two counter wedges, forcing them apart and into contact with the sides of the hole. This action generates an immensely powerful splitting force which is transmitted to the rock or concrete by the relatively small faces of the counter wedges, achieving a concentrated effect which establishes a split within seconds.*

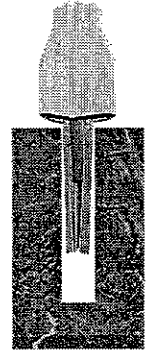

Fig. A

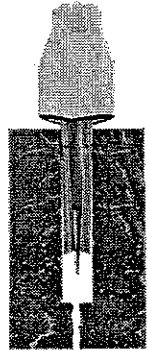

Fig. B

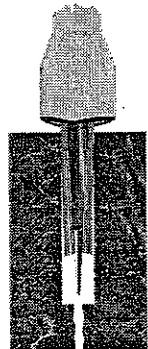

Fig. C

Fig. 2.2 (Figs. A, B, C)

## 3. Work preparations

*Before starting any splitting operations, it is advisable to carry out several drilling and splitting trials to determine the arrangement and number of drill-holes required and the maximum possible distance between them. Since drilling takes significantly longer than splitting, as few holes as possible should be drilled.*

*If dealing with reinforced concrete, determine the thickness and locations of the steel rods, then assess the best positions for drilling and splitting. Needless to say, it is advisable to drill between the rods. Reinforcements of 6 - 10 mm in thickness can be drilled through with a conventional pneumatic hammer drill, but this is time-consuming and relatively uneconomical. Since no set rules exist for splitting procedures, but merely parameters derived from experience, it is necessary to determine the best procedure for each individual demolition project. Splitting trials will reveal the properties of the material and how it will break.*

*To make demolition work faster and more cost effective, split blocks of concrete or rock should always be as large as possible, commensurate with the load capacity of the transport vehicles employed.*

*Before starting work, machine operators must have read and understood the separate Operating Instructions for the splitting cylinders and hydraulic pump units they will be using, paying particular attention to the safety regulations and precautions. They must also be in a suitable mental and physical state, otherwise they may expose themselves to a risk of serious or even fatal injury and/or damage their equipment or other property.*

### **Caution!**

*When boulders or large freestanding blocks of rock and concrete are split, the split pieces may fall to the ground. For this reason, never stand on or near the block and note in advance where the pieces may fall.*

*Under adverse conditions, the splitting cylinder may jerk sideways during a splitting process. For this reason, never bend over the splitting cylinder. In every case, maintain a safe distance of at least one arm's length. During the splitting process, do not place the hands on the splitting cylinder or hydraulic hoses.*

*Do not use the wedge set as a chisel. It could get bent or snap off entirely.*

# 4. Drilling

## 4.1 Drilling machines

To permit the use of the hydraulic splitter, a hole must be drilled into which the splitting cylinder wedge and counter wedges can be inserted. Holes are usually made with a conventional, hand-held pneumatic hammer drill, a simple, straightforward process. In quarries, large machines capable of drilling several holes simultaneously are used. Dust extractors or water sprinklers can be used to eliminate dust.

Where necessary, the use of diamond tipped core drills will prevent dirt, dust, noise and vibrations (e.g. in hospitals, computer centres, office buildings, etc.).

To resolve the problem of finding a suitable drilling method, DARDA has developed two small yet extremely efficient drill rigs designated DR 086 and DR 17. These are fitted to the arm of a mini-excavator, advanced hydraulically and driven by a compressor. A combination of a DR 086 or DR 17 with splitting machines resolves any problems entirely. DARDA can also supply pneumatic hammer drills.

**During drilling operations, observe the following instructions without fail.**

## 4.2 Requisite drill-hole diameter

It is essential for the hole to be of the exact diameter for the wedge set of the respective type of splitting cylinder used. If it is too small, the wedge set will not fit into it. If it is too large, the gap between the wedge set and the sides of the hole will be excessive and the wedge will be unable to force the counter wedges against the sides of the hole with sufficient pressure (or even at all).

As a result, the material will fail to split. The diameter of the drill-hole must therefore be just big enough for the wedge set to fit precisely with the wedge retracted (see 4.4).

If a C 9 N or C 12 N splitting cylinder with pressure shells is used, a core drill hole of 100 mm in diameter is required.

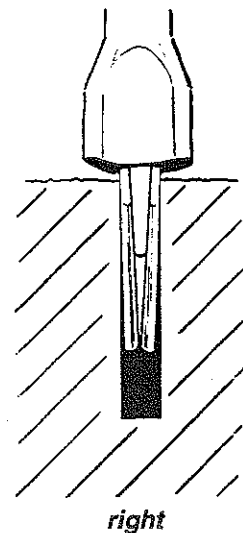
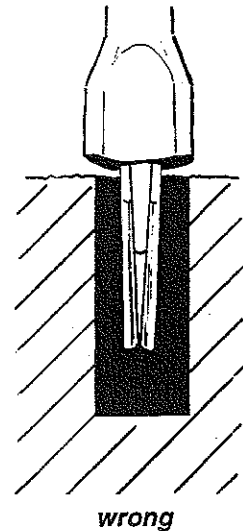

Fig. 4.2

### 4.3 Requisite drill-hole depth

The drill-hole must be deep enough to allow for the wedge in extended condition, without fail. If it is too shallow, or if dirt or small pieces of rock fall into it, reducing its depth, the wedge will strike the bottom of the hole and possibly snap off. In short, the drill-hole must be deeper than the length of the wedge set with the wedge extended (see 4.4).

Fig. 4.3

Before the splitting cylinder is used, it is advisable to re-check the depth of the hole with a tape measure.

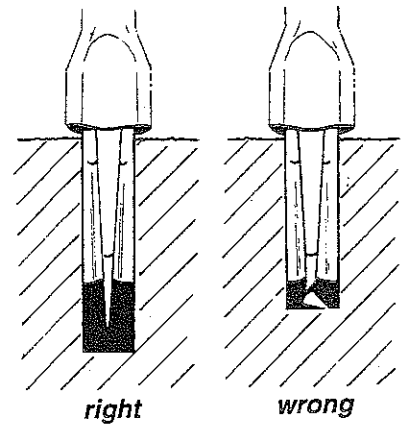

### 4.4 Requisite drill-hole dimensions

The drill-hole dimensions for the respective types of splitting cylinder shown below must be adhered to by the drill operator without fail.

Splitting cylinder Model	Drill-hole diameter mm	Minimum hole depth, mm	Drill-hole diameter for pressure shells, mm	Minimum hole depth for pressure shells, mm
C 2 SN	32	270	-	-
C 4 N	35 — 38	430	-	-
C 4 WL	35 — 38	540	-	-
C 4 WLL	36 — 38	700	-	-
C 9 N	45 — 48	410	100	410
C 9 L	45 — 48	580	-	-
C 9 LL	48 — 50	1080	-	-
C 10 SN	41 — 43	630	-	-
C 12 N	45 — 48	610	100	610
C 12 L	45 — 48	680	-	-

Suitable drill bits of precisely the right dimensions for each splitting cylinder model are available from DARDA

### 4.5 Drill-hole straightness

The drill-hole should be as straight as possible, otherwise the advancing wedge will strike the side of the hole, possibly bending the wedge set and causing it to snap off. In addition, longer wedge sets may not fit into the hole at all.

Fig. 4.5

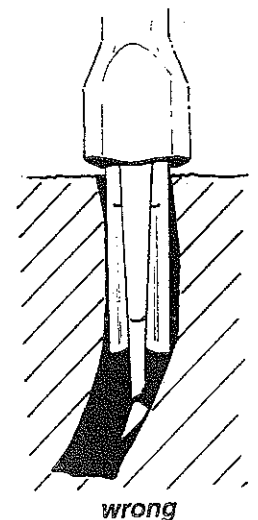

#### 4.6 Requisite drill-hole position

It is important to choose the correct position for the drill-hole to obtain satisfactory results. Try to picture the eventual split before starting drilling.

These diagrams show the correct position. The hole should be drilled at an angle of  $90^\circ$ , i.e. perpendicular to and in the centre of the flat surface of the block of rock or concrete. If the hole is drilled at a shallower angle or too near the edge, it is possible that only a small piece of the material will break off and that no split will result.

Fig. 4.6.1

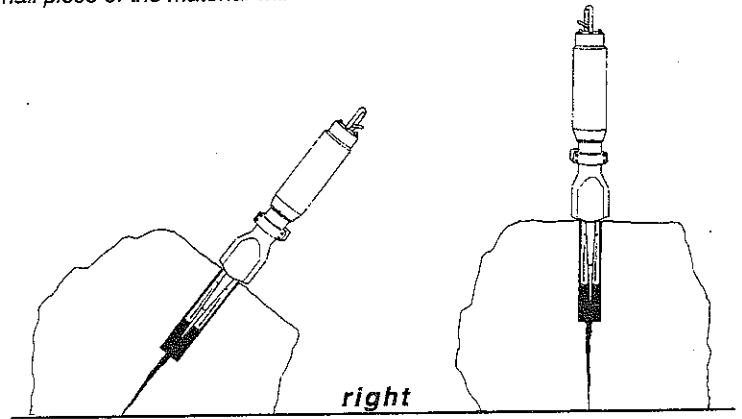

These diagrams depict incorrect positions for the drill-hole. The wedge set is not perpendicular to the surface and is unable to apply its force in the correct manner. The wedge set will simply shift to the weak side of the block because the force will pursue the line of least resistance. The probable result is that only a small piece of material will break off. At the same time, the wedge and counter wedges may be bent or snap off.

Fig. 4.6.2

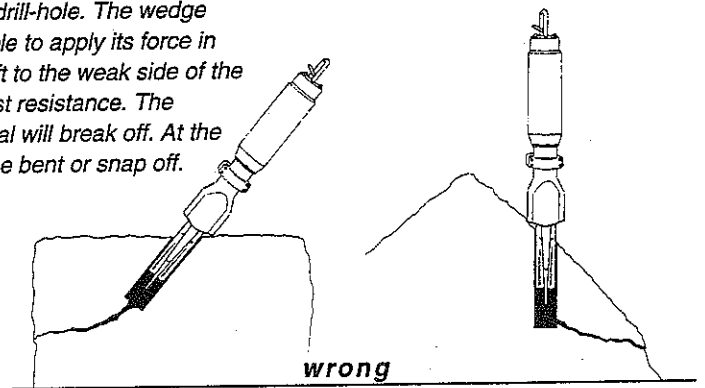

If the holes are drilled too close to the edge of the block, the same uneconomic outcome will result, i.e. instead of straight split, only small pieces will break off. For these reasons, therefore, a sufficient distance must always be allowed between the drill-holes and the edge of the block.

##### Examples:

Holes were drilled in a block of material measuring 1.2 x 1.2 m at a distance of 20 cm from the edge. The splitting process produced only small, triangular pieces (1).

A single hole is drilled in another block of material of the same size, 60 cm from the edge. The block can now be split relatively accurately into two halves (2).

(1) wrong

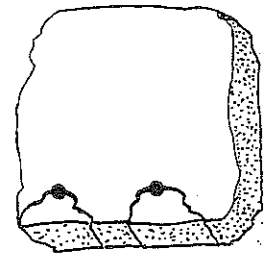

(2) right

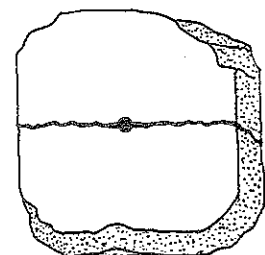

Fig. 4.6.3

# 5. The splitting process

## 5.1 Using the splitter

1) Insert the splitting cylinder wedge set, consisting of a wedge located between two counter wedges, into the accurately drilled hole (see 4.4). The control valve lever on the splitting cylinder must be in the 'R' (Return) position and the wedge fully retracted. The wedge set must be inserted into the hole to at least 3/4 of its length and preferably completely.

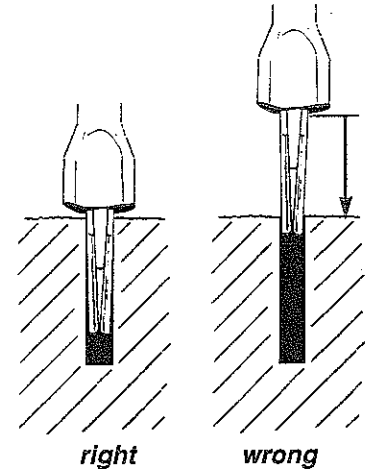

Fig. 5.1.1

2) Set the control valve lever to 'F' (Forward) to start the splitting process. The control valve controls the advancing and retracting movements of the wedge. Pressure builds up in the system limited to 50 MPa (500 bar) by a pressure relief valve on the hydraulic pump unit. The utmost safety is thus assured.

A piston in the splitting cylinder advances under hydraulic pressure, driving the wedge attached to it between the two counter wedges, forcing them apart. A split develops within a few seconds. Thin reinforcing rods break off, while thicker rods are exposed in the gap.

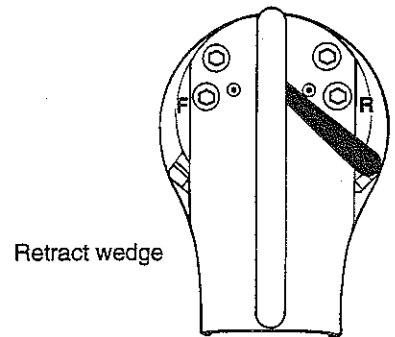
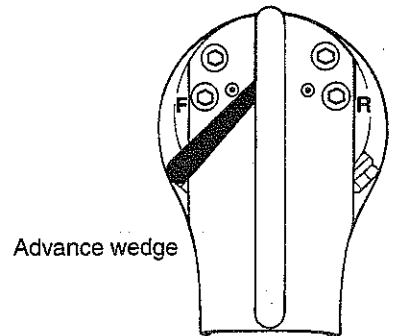

Fig. 5.1.2

3) As soon as the wedge is fully advanced, the pressure relief valve on the hydraulic pump unit relieves the pressure in the splitting cylinder (signified by a noticeable report) whereupon the hydraulic pressure falls to about 65 bar.

The split must now be made secure, e.g. with a steel wedge, to prevent it from closing again when the splitting cylinder is removed from the hole. Now move the control valve lever to 'R' (Return), on the other side of the handle, to retract the wedge.



4) When the wedge is fully retracted, the pressure relief valve again relieves the pressure in the splitting cylinder (another report) and the pressure again falls to about 65 bar. The splitting cylinder can now be removed from the hole and the splitting process repeated in the next hole.

5) To depressurize the hydraulic system on completing splitting operations or before a prolonged break, it is advisable to switch off the hydraulic pump unit or at least to set the control valve lever to the central, neutral position, otherwise the hydraulic fluid in the system will overheat, giving rise to possible problems.

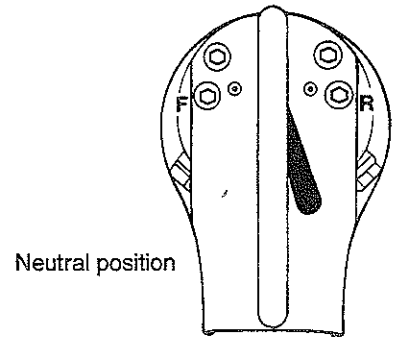

6) Thick reinforcing rods which have not snapped off can be cut through with a suitable tool, e.g. DARDA HCS 5 combi-shears (see 6.3).

## 5.2 Determining the direction of the split

The direction of the split can be readily determined in advance, i.e. the same direction as the upper handle of the splitting cylinder. Provided the handle is facing in the direction of the proposed split, the counter wedges and wedge will be in the right position.

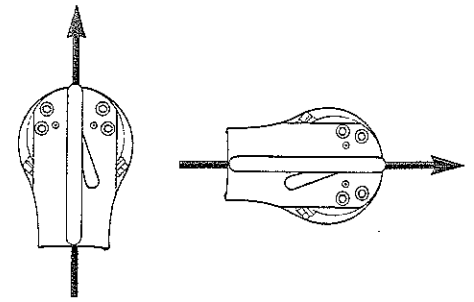

Fig. 5.2.1

The example illustrated alongside is generally applicable. The broken line in Fig. 5.2.2 indicates the intended split. The splitting cylinder is inserted into the drill-hole in the centre of the block of rock or concrete, with the handle pointing in the same direction as the intended split.

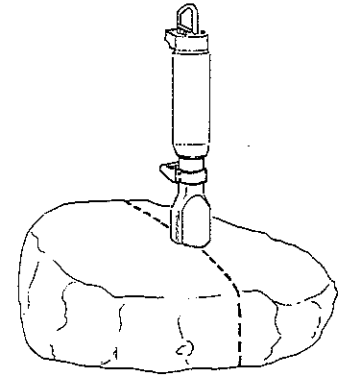

Fig. 5.2.2

The splitter will now split the block relatively accurately along the broken line. The precise progression of the split, needless to say, depends on the structure, hardness and quality of the rock or concrete.

## 5.3 Splitting with multiple splitting cylinders

Splitting cylinders have an effective splitting force of between 1,962 kN (195 t) and 4,048 kN (413 t), depending on model.

If the blocks are particularly large or hard, one splitting cylinder may not be adequate, in which case two or more must be used simultaneously. The individual splitting forces achieve a cumulative effect, e.g. five C 12 L cylinders (413 t per cylinder) generate a combined splitting force exceeding 20,200 kN (over 2000 t).

A single hydraulic pump unit is capable of driving several splitting cylinders simultaneously (up to six cylinders, depending on pump type).

The handles on all the splitting cylinders arranged in a row must face in the same direction to ensure a uniform split.

All the control valve levers must be set to 'F' (Forward), otherwise there will be no build-up of hydraulic pressure.

### Example:

Since the block of rock shown in Fig. 5.3 is too big for a single splitting cylinder, a second cylinder is needed. Two holes are drilled in the centre of the block, 40 - 60 cm apart (the distance depends on the susceptibility of the rock to being split), and a splitting cylinder inserted into each hole. Both handles are pointing in the intended direction of the split and the combined force is sufficient to split the large block.

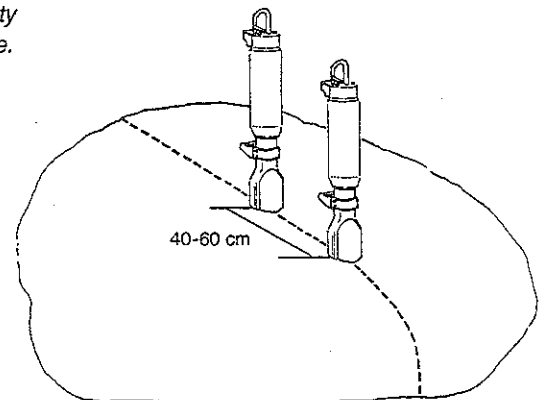

Fig. 5.3

## 5.4 Long, straight split with multiple splitting cylinders

To accomplish the pure disintegration of concrete or stone in cases where it is not essential for the split to be precise and straight, one or two splitting cylinders will generally prove adequate.

If, however, an unusually long, precise fracture is required, two or more cylinders should be used. This occurs most frequently in the case of concrete demolition when e.g. part of a large structure is required to remain standing, necessitating an accurate split. In such cases, the following method must be used.

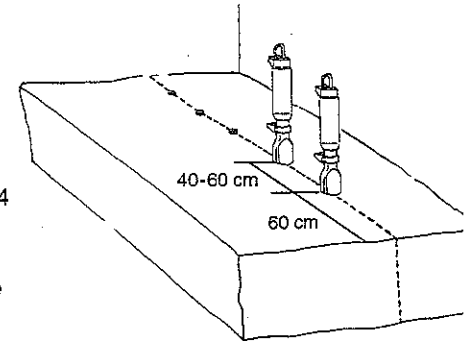

Fig. 5.4

1) Drill holes in a straight line at intervals of 40 - 60 cm, depending on the type and dimensions of the material, over the entire length of the concrete section. Position the outermost holes about 60 cm from each end.

2) Insert wedge sets into drill-holes, align the handles and set the control valve levers to 'F'. This will produce a partial split, without necessarily fracturing the concrete over its entire length. It is important to pay particular attention to the formation of the split. In most cases, it is not necessary to use every drill-hole. Often, the action of a splitting cylinder in every second or third hole is sufficient. The unused holes control the progression of the split because the structure of the concrete has been weakened at these points.

3) After the first splitting process, secure the split with a wedge, reposition the splitting cylinders in the following holes and establish a further partial split. Repeat this process until the concrete section is split over its entire length.

4) In the case of exceptionally large or long concrete sections, it may often be necessary to conclude by widening the gap between the split section and the main structure in order to establish complete separation, break off reinforcing rods or expose the split faces. In this case, all the splitting cylinders should be distributed over the entire length of the split and a final splitting process carried out, preferably with enlarging counter wedges, to separate the split section from the main structure entirely.

## 5.5 Splitting wedged blocks

When wedged blocks of rock or concrete, which cannot be separated sideways, are split, the material on at least one side will lift, forcing one of the two counter wedges up with it. The other counter wedge will be drawn downwards with the result that the wedge set may snap off.

Fig. 5.5

In addition, the splitting cylinder will be jerked sideways, bending the wedge set out of shape or even snapping it off. If the splitting cylinder is inclined by more than 10 cm, the wedge should therefore be retracted immediately.

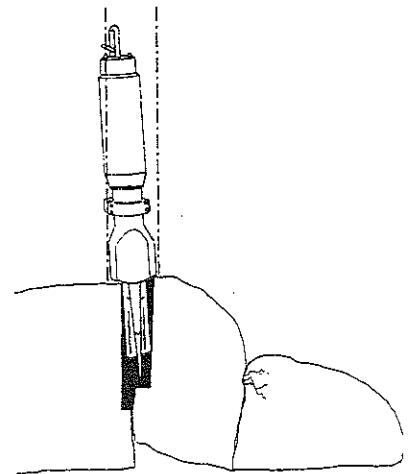

## 5.6 Splitting with pressure shells

Since the wedge sets used by DARDA splitting cylinders are relatively narrow, they require a drill-hole of correspondingly small diameter. As a result, the extreme splitting force acts on the extremely small area occupied by the counter wedges and sides of the drill-hole (see 2.2, 'Wedge principle'). Under normal circumstances, this constitutes a noteworthy advantage.

In extreme cases involving exceptionally heavily reinforced concrete, however, the immense surface pressure may merely compress the concrete, resulting in an oval drill-hole surrounded by short, random cracks. The concrete fails to split and the reinforcing rods remain intact.

This problem can be resolved with two heavy-gauge, large diameter pressure shells, which transmit the splitting force over a greater area.

- 1) With a diamond-tipped core drill, drill a hole, 100 mm in diameter and necessarily deeper than the length of the shells. Depending on the type of splitting cylinder used, the minimum depth must correspond precisely to that specified in 4.4.
- 2) Insert both pressure shells into the hole.
- 3) Insert the wedge set into the gap between the pressure shells in such a way that they can be forced apart, otherwise the splitting process will be ineffectual (see drawings).
- 4) Carry out the splitting procedure as usual, using enlarging counter wedges if necessary and leaving the pressure shells in the hole.
- 5) Despite the heavy reinforcement, this will produce a precise split and expose the reinforcing rods which can then be simply cut through in the gap.

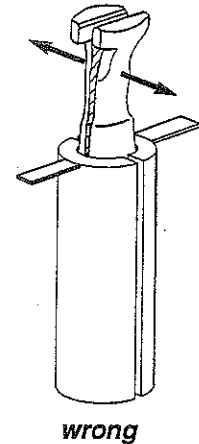
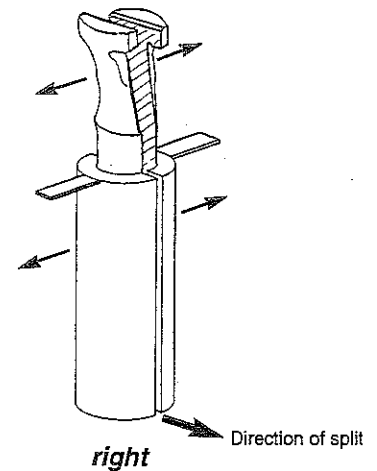

Fig. 5.6

## 6. Enlarging a split

### 6.1 Installing the enlarging counter wedges

After the initial split has been made, it can be enlarged by replacing the normal counter wedges with thicker enlarging counter wedges, a quick, straightforward process.

- 1) Place the splitting cylinder on a flat surface, set the control valve lever to 'R' and fully retract the wedge.
- 2) For the enlarging process, first remove only one counter wedge and replace it with an enlarging counter wedge. The counter wedges are mounted in the front head. With a screwdriver (1) release the two clasps (2) in the splitting cylinder front head (Fig. A).
- 3) Push the wedge (3) and both counter wedges (4) to one side (Fig. B).

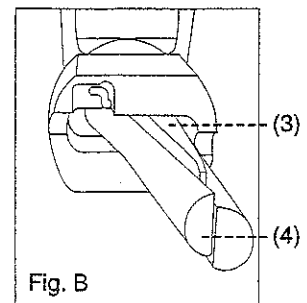
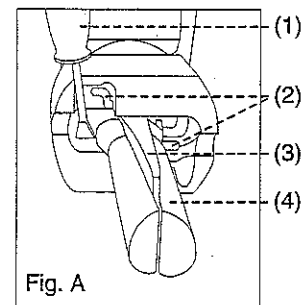

- 4) Turn the counter wedge on the free side through 90° and pull out (Fig. C).
- 5) Install an enlarging counter wedge in the reverse order and resecure the clasps.

Fig. 6.1. (Figs. A, B, C)

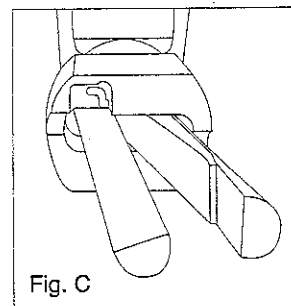

### **6.2 Enlarging with enlarging counter wedges**

Reinsert the wedge set (now including a thicker enlarging counter wedge) into the drill-hole and repeat the splitting process, widening the split. Secure the enlarged split with a steel wedge or similar.

Fig. 6.2

Now replace the second counter wedge with an enlarging counter wedge, repeating points 1) - 5) (see 6.1) on the other side.

With the two enlarging counter wedges, the split can now be enlarged to its maximum width. Exceptionally thick reinforcing rods which are not snapped off in the initial splitting process will now break or become accessible to a separating or cutting tool. DARDA HCS 5 C combi-shears are particularly suitable for this purpose (see 6.3).

The same procedure is used if the split has previously been made with pressure shells, except that the shells remain in the hole during the enlarging process.

An already enlarged split can be widened still further with the special enlarging counter wedges, which are considerably thicker than their standard counterparts. The procedure is identical.

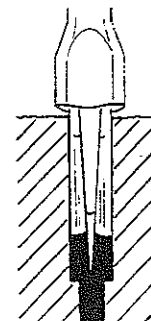
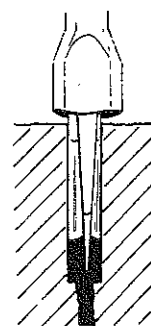
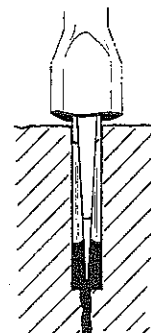

### **6.3 Enlarging splits and cutting reinforcing rods with HCS 5 C combi-shears**

The DARDA HCS 5 C combi-shears (equipped with cutting tools) can be used substantially to enlarge a split which has already been widened with standard or special enlarging counter wedges. Blocks of concrete or rock can be forced apart or lifted.

- 1) Insert the steel tips of the shears into the split or gap between the blocks of material.
- 2) Press the control valve lever to 'Open' and hold it in that position. The shear arms will open, forcing the concrete or stone as far apart as possible (maximum width 32 cm).

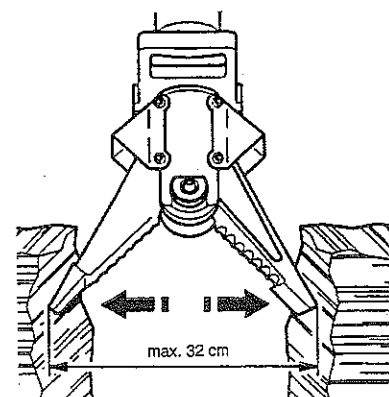

Fig. 6.3.1

3) The HCS 5 C can also be used to cut reinforcing rods. Insert the shears into the gap, placing the rod between the blades. To make full use of their cutting force, position the rod as far up the blades as possible. Now press the control valve lever to 'Close', whereupon the blades will close and cut through reinforcing rods up to 18 mm in diameter.

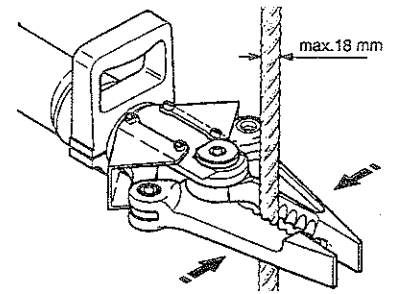

Fig. 6.3.2

Note:

With a manifold, HCS 5 combi-shears can be connected to a common hydraulic pump unit with one or more splitting cylinders and operated alternately.

#### 6.4 Enlarging with enlarging feathers

A split in natural stone can be enlarged with so-called 'enlarging feathers'. Available for the C 2 SN and C 4 N, they must be used in corresponding pairs.

The procedure is as follows:

1) First secure the split with a steel wedge or another splitting cylinder to prevent it from closing again.

2) Insert the enlarging feather with the wide end into the hole completely (Fig. A (1)). Push the second feather with the narrow end in behind the first feather, together with the wedge set (Fig. A (2)). Insert these as far as possible into the hole. The top of the feather should rest against the splitting cylinder front head and the wedge be fully retracted.

3) Set the control valve lever to 'F', advancing the wedge as far as it will go, thus enlarging the split.

4) Secure the split again, then retract the wedge (set lever to 'R').

5) Push the upper enlarging feather deeper into the hole with the splitting cylinder (Fig. B (3)) and advance the wedge again.

6) Repeat the entire procedure until the upper enlarging feather is fully inserted into the hole (Fig. C (4)).

7) Now repeat this process with the second pair of enlarging feathers (Fig. C (5)), leaving the first pair still in the hole.

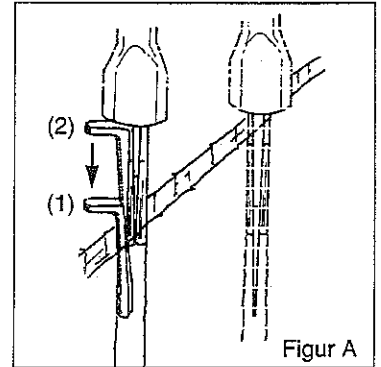

Figur A

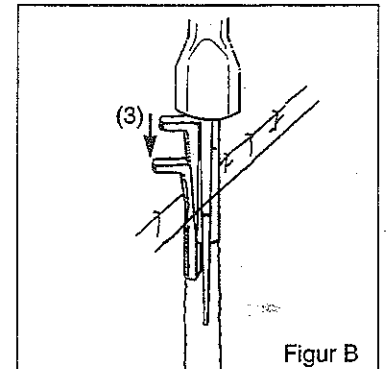

Figur B

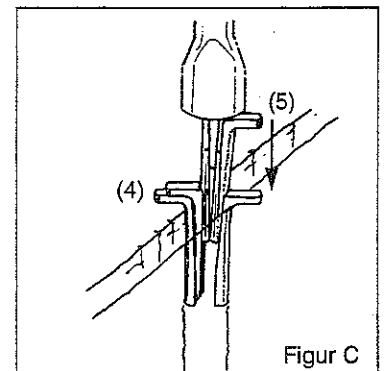

Figur C

Fig. 6.4 (Figs. A, B, C)

The effectiveness of this enlarging process derives from the differences in thickness of the ends of the enlarging feathers and the repetitive action whereby the feathers constantly occupy the gap between the wedge set and the sides of the hole. In this way, the splitting action is used to the optimum extent and the split enlarged to the maximum achievable width.

# 7. Routine maintenance

## 7.1 Lubricating the wedge set

During the splitting process, exceptionally high forces act on the wedge and counter wedges, which must then transmit them to the rock or concrete. For this to take place with only negligible friction losses, the contact faces of the wedge set must be regularly lubricated with special DARDA lubricant, without fail. This was specially developed for this specific purpose and is the only lubricant capable of withstanding the extreme friction and heat generated by the splitting process and consequently to reduce friction losses to the requisite extent. Compared with standard, unsuitable lubricants, the splitting force obtained with DARDA lubricant is 20 - 50% higher. It is also waterproof and can be used in temperatures ranging from  $-30^{\circ}\text{C}$  to  $+250^{\circ}\text{C}$ .



Fig. 7.1.1

Lubricating procedure:

- 1) With a screwdriver or similar, spread the wedge and one counter wedge apart to gain access to the contact faces.
- 2) With a spatula, apply a thin, even coating of DARDA lubricant to the contact faces of the wedge and counter wedge.
- 3) Repeat this process with the second counter wedge.
- 4) Apply lubricant after approximately eight splitting processes at the latest, or sooner if working on very hard rock or heavily reinforced concrete.

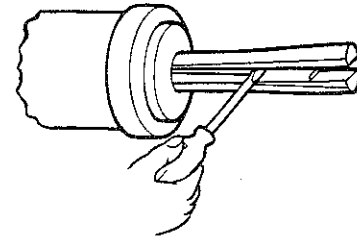

Fig. 7.1.2

If lubrication is not carried out regularly, or lubricants other than special DARDA lubricant are used, we will not accept any liability for any damage which may occur to the wedge set or splitting cylinder.

## 7.2 Checking the hydraulic fluid level

The fluid level in the hydraulic pump tank must be checked on every occasion before splitting operations are started. To do this, simply withdraw the dipstick which is marked with the minimum and maximum oil levels. Carry out the first oil change on a new pump unit after about 200 operating hours, then about every 1000 operating hours.

DARDA hydraulic fluid should be used exclusively with DARDA hydraulic rock and concrete splitting machines.

Under extremely cold conditions, a lower viscosity fluid is advisable (or a higher viscosity fluid in exceptionally hot conditions). Different grades of fluid must not be mixed, since this may adversely affect lubrication.

# 8. Demolishing solid and reinforced concrete

## 8.1 Concrete walls and panels

A concrete wall or even a concrete panel lying on its side should be split in accordance with the methods shown here. The distance between the drill-holes depends on:

- how easily the concrete splits,
- whether it is plain or reinforced concrete and how thick the reinforcing rods are,
- how big the split pieces of concrete should be (for transporting purposes).

Before starting, it is advisable to carry out a number of drilling and splitting trials, after which all the holes can be drilled at once. Often, only a relatively small number of holes is required.

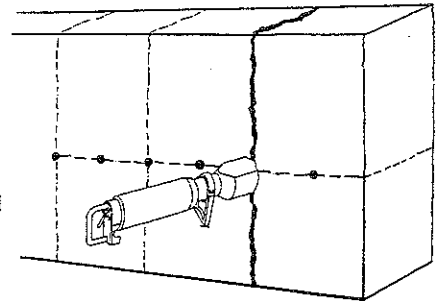

Fig. 8.1.1

Fig. 8.1.1 depicts the best method for splitting concrete containing light- to medium-gauge reinforcement. First, split the wall or panel vertically, then produce rectangular blocks with horizontal splits. A single splitting cylinder is usually sufficient, or two at most.

Light- to medium-gauge reinforcing rods usually snap off of their own accord. If not, it is advisable to produce blocks of the largest practical size, so as to minimise the number of rods which must be cut off, e.g. with DARDA HCS 5 combi-shears (see 6.3).

If the concrete contains exceptionally heavy-gauge reinforcing rods which are not snapped off by the splitting process, the method shown in Fig. 8.1.2 may prove effective. In this case, position the splitting cylinder at an angle of 45°, allowing the concrete to be pulled clear over the reinforcing rods. The latter are exposed in the split and can then be cut off.

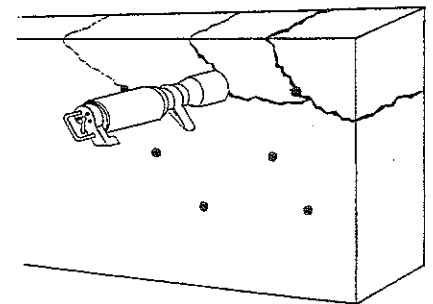

Fig. 8.1.2

## 8.2 Very thin concrete walls

If a wall is thinner than the length of the wedge set, two risks arise, i.e.

If the wedge set projects too far out of the back of the wall, all the splitting force will be applied beyond the wall at the ends of the counter wedges, bending or snapping them off and leaving the wall unaffected.

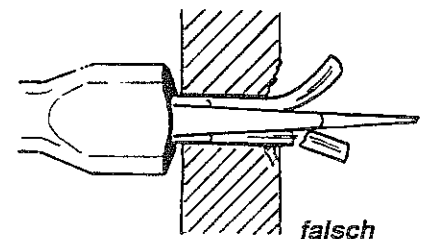

Fig. 8.2.1

If the wedge set is not inserted far enough into the wall, the counter wedges may bend outwards and break.

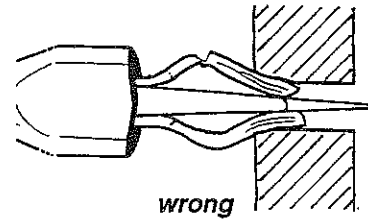

Fig. 8.2.2

The correct method is to insert the wedge set into the wall only so far as is needed to ensure that the centre section is positioned in the wall (see 8.2.3).

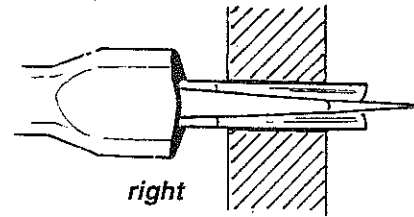

Fig. 8.2.3

The splitting cylinder should be securely held until the wedge has advanced to a sufficient extent to hold the splitting cylinder in the hole of its own accord. This will prevent it from twisting and shifting in an uncontrolled manner, i.e. it will then maintain its position in the hole.

### 8.3 Partial demolition

If only part of a wall (or any other structure, such as a bridge) is to be demolished, leaving the other part standing and intact, the first essential is to establish a limiting split. This will prevent cracks from forming in the preserved part.

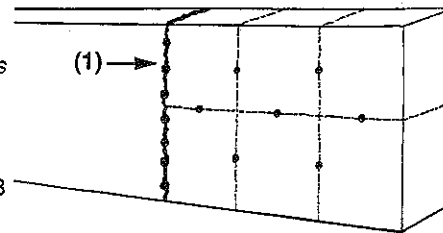

Fig. 8.3

Fig. 8.3 depicts a situation of this type. In this case, the vertical limiting split (1) was established first. The drill-holes are relatively close together (approximately 30 cm) to ensure that the split is as straight as possible. Depending on the size of the structure and length of the limiting split, the use of several splitting cylinders is advisable, or possibly essential, to obtain a precise split (for the correct procedure, see 5.3 and 5.4).

### 8.4 Making an opening in a concrete wall (combined use of diamond-tipped saw and splitter)

To make a precise opening in a concrete wall, reinforced or otherwise, it is advisable to use a combination of a diamond-tipped saw and a splitter.

#### a) Very thin walls:

In the case of very thin walls, push the sawn-out section forward and tip it out. With a splitter, break down the removed section into small, easily transportable pieces.

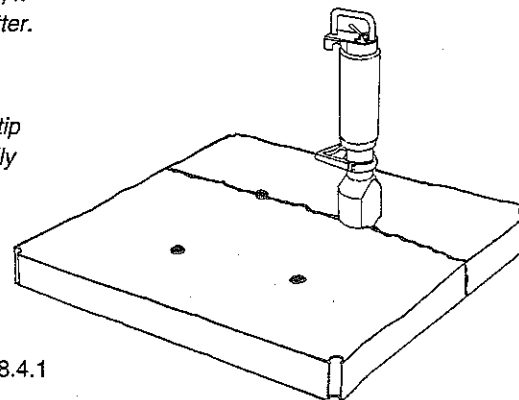

Fig. 8.4.1

**b) Thick concrete walls:**

In most cases, the sawn-out concrete section cannot easily be pushed out because it is too thick or heavy. A second saw cut (1) must therefore be made, 30 - 40 cm below the upper horizontal saw cut. Press out the resulting small, narrow piece of concrete.

Tip the large, lower piece of the wall out and reduce it with a splitter. If it is difficult to dislodge, it can be drilled and split into convenient pieces while still in the wall (2).

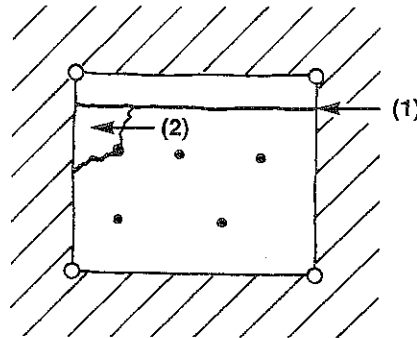

Fig. 8.4.2

**8.5 Capping off concrete piles**

The heads of concrete piles can be removed in two ways, i.e.

**a) Heavily reinforced concrete:**

- 1) With a suitable tool (demolition hammer, hydraulic chisel) carefully expose the reinforcing rods.
- 2) Make a horizontal limiting split (1) so as to prevent subsequent damage to the lower part of the pile. To do this, drill a hole in the side of the pile and make the split with a splitting cylinder (with the handle horizontal). If the pile is particularly thick, use two splitting cylinders on opposite sides simultaneously.
- 3) Now install suitable pegs or hooks in the top of the pile, enabling the head to be raised and lifted clear with a cable attached to a crane or block and tackle (Fig. A).

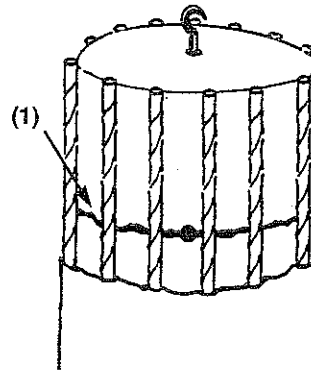

Fig. A

Fig. 8.5.1

Alternatively:

- 3) With a hammer drill, drill holes in the top and sides of the pre-split pile head and demolish it with a splitter (2) (Fig. B). The small pieces of concrete can be removed by hand.

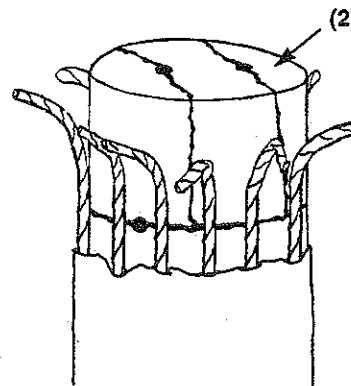

Fig. B

Fig. 8.5.2

**b) Lightly reinforced concrete:**

- 1) Instead of exposing the reinforcing rods, drill a hole in the side of the pile between reinforcing rods and make a limiting split (1) with a splitting cylinder. Do not enlarge this split excessively, otherwise the reinforcing rods will be stretched.
- 2) Drill holes in the top and sides of the pile head between the reinforcing rods and use a splitting cylinder to break down the concrete into several conveniently-sized pieces. These can then easily be removed.

Tip:

If, before the concrete is poured, rubber tubes are drawn over the upper ends of the reinforcing rods down to the level at which the pile is subsequently to be capped off, the capping operation will be considerably simplified. Since the concrete is unable to bond with the steel rods in this area, the pile head can be lifted off more easily after being split.

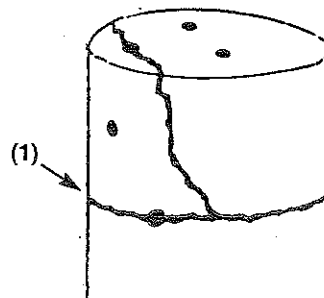

Fig. 8.5.3

## **8.6 Concrete blocks with extensive reinforcement**

The reinforcement for machine foundations or similar concrete sections often takes the form of a cage or is laid in mats near the edge of the foundation. The rods are also frequently very thick. In such cases, the following procedure is advised.

- 1) With a hammer drill, drill holes in the top of the foundation, towards the edge and between and behind the reinforcing rods. With a splitter, establish splits so that the structure of the concrete disintegrates.
- 2) The rods can then be exposed relatively easily with a demolition hammer.
- 3) Bend the rods outwards or remove with a suitable tool, e.g. Darda HCS 5 combi-shears (see 6.3).
- 4) Now drill holes at suitable intervals into the remaining, unreinforced part of the foundation and split it into conveniently sized pieces with a splitter.

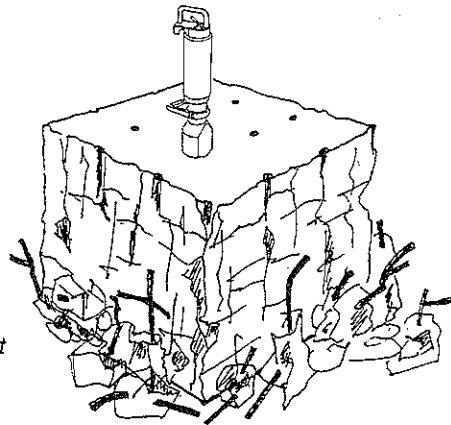

Fig. 8.6

# 9. Demolishing rock and natural stone

## **9.1 Rock excavation**

During soil excavation work, e.g. for trenches or basements, it is not unusual for progress to be obstructed by solid rock. If the use of explosives is prohibited or impractical, hydraulic splitters offer an efficient, safe method of rapidly removing the obstacle.

Splits should always be made on the open side so as to permit the split pieces to move. If, however, the task involves demolishing an area of rock with a flat surface and without an open side, a clear space must be made with a splitter in the following way.

Under normal circumstances, the splitting cylinder must always be positioned at an angle of 90° to the rock face. This particular situation is an exception to the rule. The holes should be drilled at an angle of about 45° to the surface and the wedge set inserted into the hole with the handle horizontal. The split will then run towards the surface, breaking out a small piece of rock. Repeat this process until a clear space has been established.

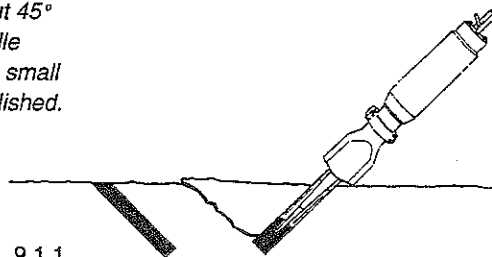

Fig. 9.1.1

Further splitting operations can now take place as usual towards the cleared space. The number of drill-holes required and intervening intervals will depend on the properties of the rock itself.

As a rule, one or two splitting cylinders will be sufficient to break out pieces of rock. If it is exceptionally solid, however, it may not be possible to break it into pieces but the structure will disintegrate under the effect of the splitting processes.

In this case, the rock will have become brittle, allowing pieces to be broken out with a hydraulic chisel or demolition hammer.

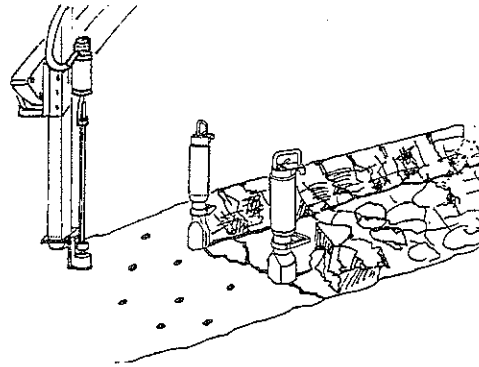

Fig. 9.1.2

If a boulder presents an obstacle during soil excavation for a trench or similar, it can be reduced in the manner described in 9.3 (also 5.2 and 5.3). It is important to make the splits towards the open side, i.e. into the trench itself.

### 9.2 Splitting stratified rock

Stratified rock cannot be split to its full depth in a single process. The split will generally stop at the point where the first layer or stratum forms a natural horizontal seam. If, nevertheless, it is necessary to split the rock over its entire depth, loosened layers must be removed as often as is necessary, the drill-hole correspondingly deepened and the splitting process repeated.

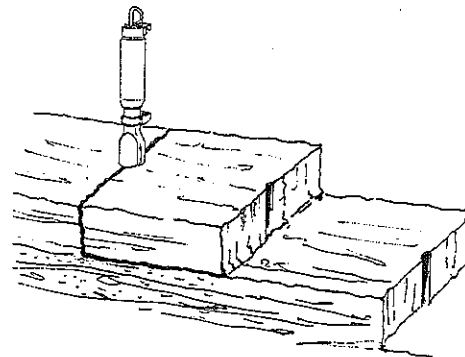

Fig. 9.2

### 9.3 Splitting freestanding boulders

Splitters are ideal for demolishing boulders or blocks of rock (and concrete sections), especially if explosives are ruled out. Drill a hole in the centre of the boulder. In most cases, a single splitting cylinder will serve to break it into two halves, which can then be further reduced with the splitter.

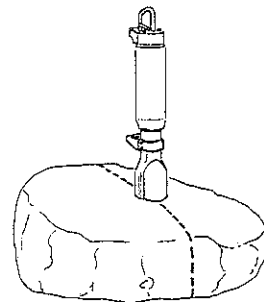
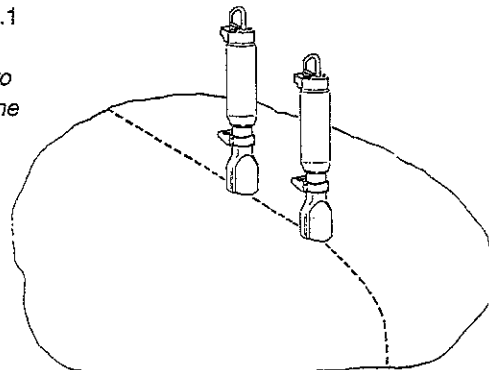

Fig. 9.3.1

If, however, the block is too large to be split with a single cylinder, drill two or more holes at intervals of 40 - 60 cm along the centre line and make the split with two or more splitting cylinders. All the handles must point in the same direction and all the control valve levers be set to advance and retract simultaneously (see 5.2 and 5.3).



If only a single splitting cylinder is available to deal with an exceptionally large boulder, an alternative method can be used, i.e. simply break it down piece by piece, starting near the edge, rather than in the centre.

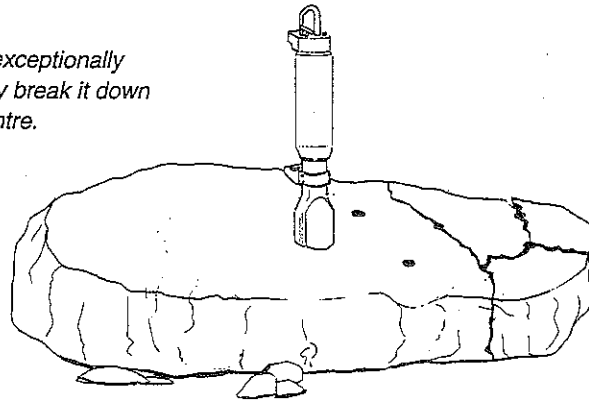

Fig. 9.3.2

When boulders or large freestanding blocks of rock are split, the separated pieces may fall to the ground. For this reason, never stand on or near the block. Keep a safe distance and note in advance where the pieces may fall.

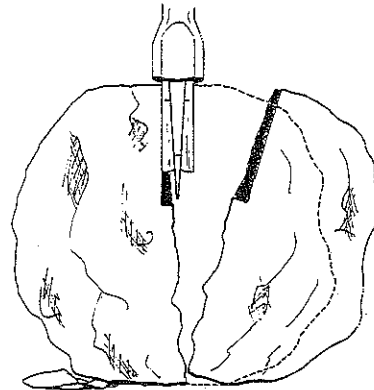

Fig. 9.3.3

To prevent the splitting cylinder from falling as well, it should be secured e.g. with a rope attached to the handle.

### 9.4 Splitting rock below ground level

During the excavation of rock in particular, it may occasionally be found that boulders extend deep into the earth below ground level. In general, it is not then possible (or necessary) to remove the entire obstacle, but merely that part projecting above the bottom of the trench or basement floor.

First, the earth should be removed on one or two sides of the boulder to the depth at which the split is to be made. It must be removed to a sufficient distance to permit the use of a hammer drill or splitting cylinder at a shallow angle. Now drill horizontal holes, as far as possible at an angle of 90° to the rock, then establish a horizontal split as a lower limit with the splitting machine (1).

In the next stage, drill into the top of the boulder and demolish the upper section with the splitter (2).

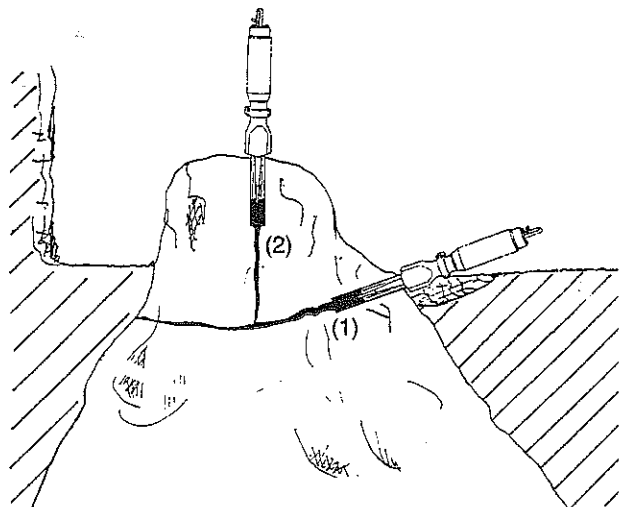

Fig. 9.4

## 9.5 Tunnel enlargement

Thanks to their convenience and the fact that they cause no vibrations, DARDA splitting machines are ideal for enlarging tunnels or mineshafts.

The following method can be used to enlarge a tunnel to the side. First, 'peel away' the outermost layer of the rock face, drilling holes at an angle, rather than at right angles to the tunnel wall. This situation represents one of the few exceptions where the holes are made at an angle other than 90°.

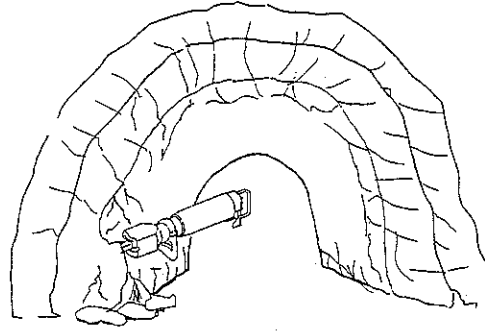

Fig. 9.5

Insert the wedge set into the hole in such a way as to direct the split towards the open side, i.e. into the tunnel itself.

From a few drilling and splitting trials, it will soon become clear how many drill-holes are needed, where they should be placed and how splitting can be carried out to the optimum effect.

Repeat the splitting process until the tunnel has been enlarged to the specified width and over the corresponding length.

## 9.6 Pipe jacking

During pipe jacking operations, obstacles frequently arise in the form of solid rocks, bringing work to a standstill.

Since, in such cases, the use of explosives is out of the question, one man with a hydraulic splitter can enter the pipe and split the offending boulder into pieces. In situations like this, the operational independence and practical convenience of a compact splitter are invaluable.

Fig. 9.6

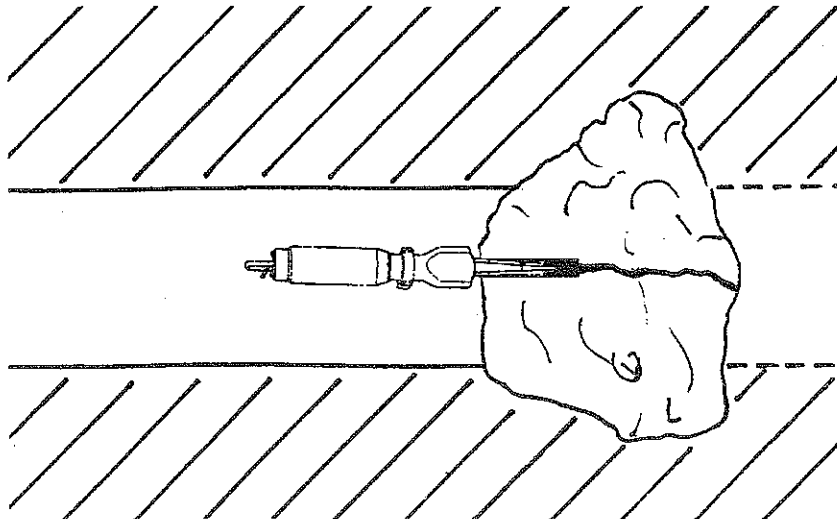

## 10. Production of natural stone blocks

Rock and concrete splitters, consisting of multiple splitting cylinders, are used for the production of natural stone blocks in quarries in the following manner.

**1)** First, jets of compressed air are used to clean the dirt and dust from the surface and reveal the structure of the rock.

The natural progression of the structure will determine how it should be split. Whenever possible, the best and most efficient method is to split along natural cracks and strata. It is also advisable to determine the size of the blocks in advance, commensurate with the handling and transport facilities available.

**2)** Now drill holes at intervals of 15 - 25 cm (depending on the material) along the line of the desired split.

**3)** Insert a C 4 or C 10 S splitting cylinder into every second or third hole. Depending on the size of the block, several splitting cylinders (up to six) should be used simultaneously, so as to ensure that the split is established in a single operation. The splitting cylinders cannot be repositioned (as described in 5.4), otherwise the split will not be as straight as it could have been or as may be required.

**4)** After positioning all the handles in the same direction, set the control valve levers to 'Forward' to achieve a precise, straight split.

**5)** If necessary, the split can be enlarged with enlarging counter wedges or feathers. In this way, the points of natural adherence in the rock will separate, allowing the block to be lifted clear of the rock layer more easily.

**6)** The block can now be transported away.

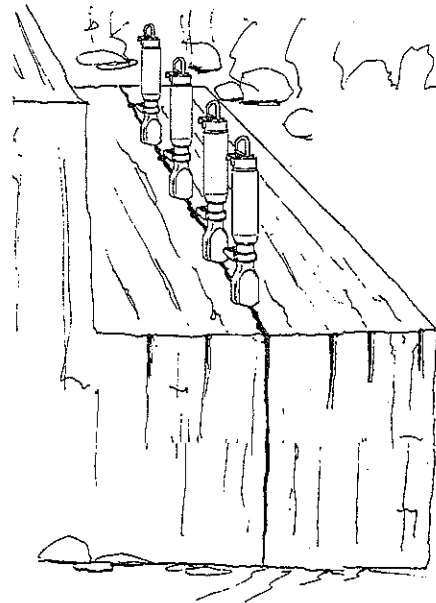

Fig. 10

This method of producing blocks with hydraulic rock and concrete splitters offers the following advantages:

- It is time-saving and economical.
- Hairline cracks, which would otherwise make the blocks unusable, do not occur - wastage is minimal.

Splitters can also be used to dress the blocks, a process for which the C 2 S splitting cylinder is particularly suitable.