







**PARTS LIST**  
**PRESSURE-MATIC VALVE**  
**06-300**

*The 06-300 pressure-matic valve is factory set to operate the hydraulic cylinder at 7100 PSI. Do not adjust to any higher setting than 7100 PSI.*

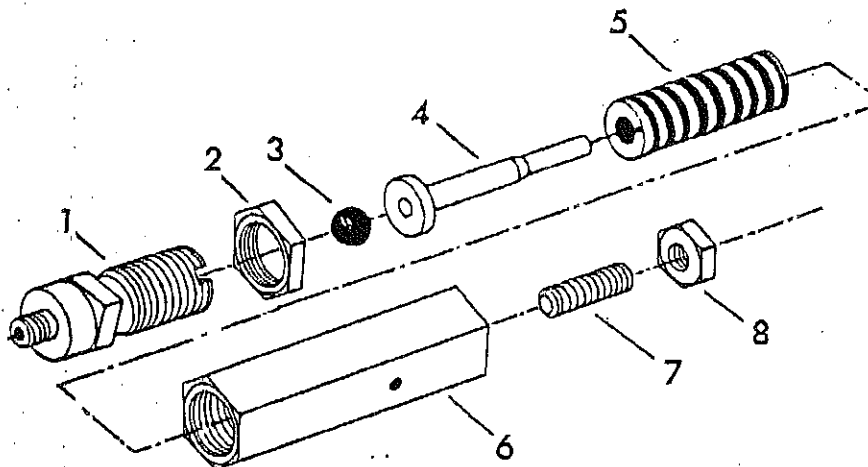

Item No.	Part No.	Description	No Req.
1	0660	Valve Seat.....	1
2	0667	Housing Lock Nut .....	1
3	0661	Ball.....	1
4	0666	Valve Stem.....	1
5	0662	Spring .....	1
6	0665	Valve Housing .....	1
7	0663	Set Screw.....	1
8	0664	Lock Nut .....	1

**PRESSURE ADJUSTMENT PROCEDURE**  
**#06-300 PRESSURE-MATIC VALVE**

(Refer to exploded view)

- 1) Remove reservoir cover plate screws and tip cover plate so you have access to the valve.
- 2) Loosen Housing Lock Nut (#2). Turn Valve Housing (#6) clockwise to increase pressure and counterclockwise to decrease pressure.
- 3) Loosen Lock Nut (#8). Turn Set Screw (#7) until it touches the end of Valve Stem (#4). Back off Set Screw (#7) ~~1/8 turn~~ *1/8 turn*.
- 4) Tighten Lock Nuts (#2) and (#8)
- 5) Recheck pressure and install cover plate.